

## Impulse and Collisions in 2D

**Q1.**

Which of the following are the base units for impulse?

- A**  $\text{kg m s}^{-1}$
- B**  $\text{kg m s}^{-2}$
- C**  $\text{N m}$
- D**  $\text{N s}$

**(Total for question = 1 mark)**

**Q2.**

A coil of wire is placed around the lower end of an iron rod. The coil is supplied with an alternating current.

A thick aluminium ring is placed around the iron rod above the coil. The coil remains in the position shown.

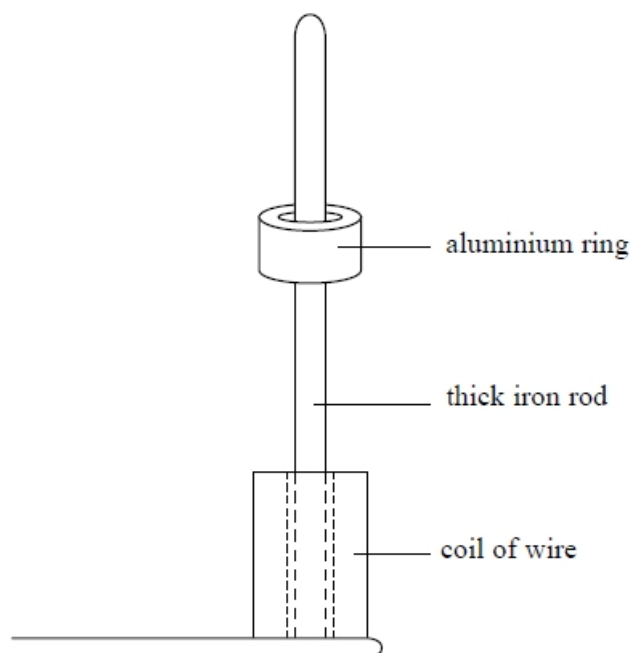

The current is switched off and the aluminium ring comes to rest on top of the coil. The supply to the coil is changed and a direct current (dc) is switched on. An upwards force  $F$  acts on the ring for 0.05 s accelerating it to a final speed,  $v$ . The ring then moves freely through a height of 30 cm.

Mean diameter of ring = 4.8 cm  
Mass of ring = 0.019 kg  
Magnetic field strength = 0.032 T

- (i) Use conservation of energy to calculate the speed  $v$  of the ring after 0.05 s. (2)

.....  
.....  
.....  
.....

$v =$  .....

- (ii) Use the idea of impulse to calculate the magnitude of the mean force  $F$  acting on the ring and hence the mean current  $I$  in the ring. (6)

.....  
.....  
.....  
.....  
.....  
.....  
.....  
.....

$F =$  .....

$I =$  .....

**(Total for question = 8 marks)**

**Q3.**

In the game of golf a stationary ball is hit by a club. One of the aims of the game is to land the ball on a patch of ground called the green.

The graph shows how the force  $F$  exerted by the club on the ball varies with time  $t$  as the ball is hit.

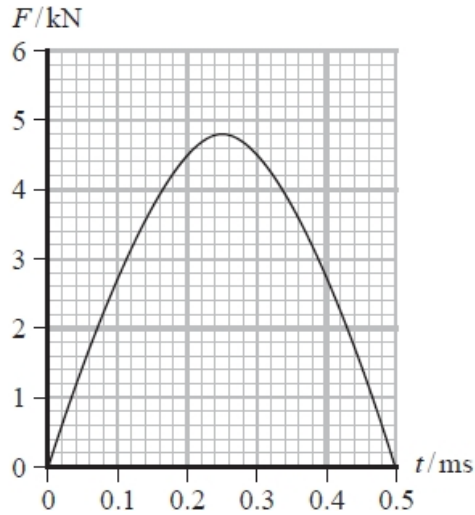

State why the area under the graph represents impulse.

(1)

.....

.....

**(Total for question = 1 mark)**

**Q4.**

A teacher is demonstrating the principle of conservation of momentum using a flat glass surface and air pucks. Lightweight tubing supplies compressed air to the pucks which is forced out from the bottom of the pucks. This means that the pucks move with very little friction across the glass surface.

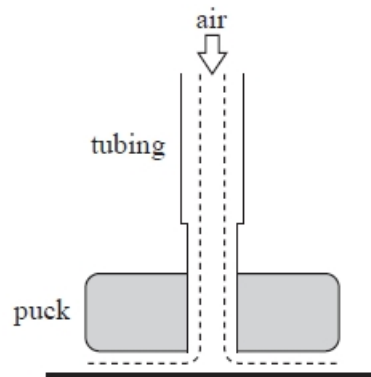
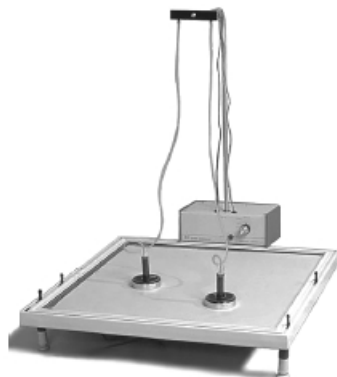



(c) The teacher uses two identical pucks to investigate collisions. In one collision, one puck moves with a velocity of  $4.0 \text{ m s}^{-1}$  and collides with a second puck that is stationary. After the collision, the first puck has a velocity  $v$  at an angle of  $30^\circ$  to its original direction, and the second puck moves off with a velocity of  $2.0 \text{ m s}^{-1}$  at an angle of  $60^\circ$  to the original direction.

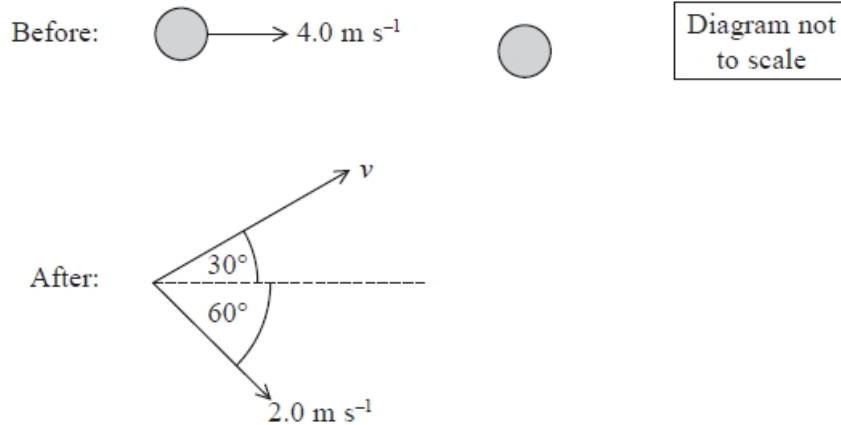

(i) Show that the magnitude of the velocity  $v$  of the first puck after the collision is about  $3.5 \text{ m s}^{-1}$ .

(3)

.....

.....

.....

.....

.....

(ii) Use the data to determine if the collision is elastic or inelastic.

(3)

.....

.....

.....

.....

.....

**(Total for question = 16 marks)**

**Q5.**

The velocity  $v$  of a non-relativistic particle can be expressed in terms of combinations of the following quantities: kinetic energy  $E_k$ , momentum  $p$  and mass  $m$ .

Which of the following expressions is correct?

A  $v = \frac{p^2}{m}$

B  $v = \sqrt{\frac{2E_k}{m}}$

C  $v = \frac{E_k}{2p}$

D  $v = \frac{2E_k}{pm}$

**(Total for question = 1 mark)**

**Q6.**

Which of the following is a possible unit for rate of change of momentum?

A  $\text{kg m s}^{-1}$

B  $\text{kg m s}^{-2}$

C  $\text{N s}$

D  $\text{N s}^{-1}$

**(Total for question = 1 mark)**

**Q7.**

A student carried out an experiment with coins.

She arranged a collision between a 2p coin and a stationary 1p coin. She noted the directions in which the coins moved after the collision and determined their velocities.

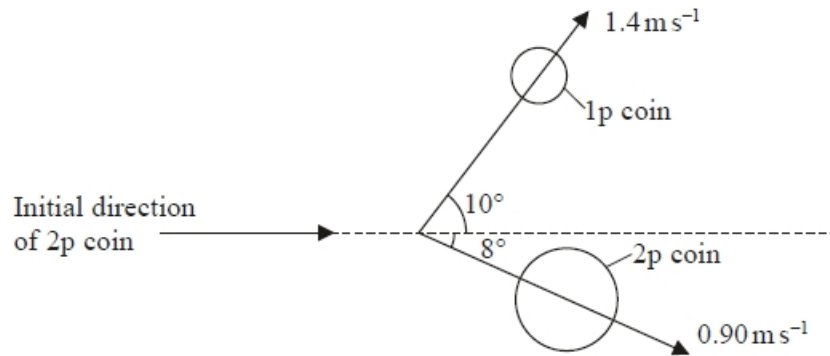

(i) Show that the velocity of the 2p coin just before the collision was about  $2 \text{ m s}^{-1}$ .

mass of 2p coin = 7.1 g

mass of 1p coin = 3.6 g

(4)

.....

.....

.....

.....

.....

.....

.....

.....

.....

.....

(ii) Show that the collision was inelastic.

(2)

.....

.....

.....

.....

.....

**(Total for question = 6 marks)**

**Q8.**

A series of experiments was carried out in the 1970s to investigate the structure of protons using the linac at Stanford, USA.

An electron leaves the accelerator with a momentum of  $20 \text{ GeV} / c$ .

(i) Explain, with reference to base units, why  $\text{GeV} / c$  can be used as a unit of momentum.

(2)

.....  
.....  
.....  
.....

(ii) An electron with initial momentum  $20 \text{ GeV} / c$  collides with a stationary proton. After the collision the electron is deflected by an angle of  $20^\circ$  as shown and its momentum is  $9.1 \text{ GeV} / c$ . The momentum of the proton after the collision is  $11.9 \text{ GeV} / c$ .

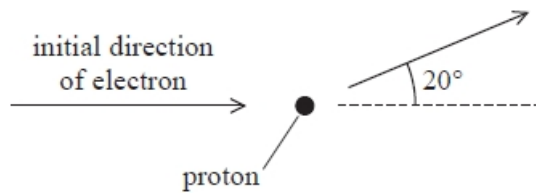

Deduce whether the law of conservation of momentum is obeyed.

(3)

.....  
.....  
.....  
.....  
.....  
.....

(iii) The collisions between electrons and the protons in these experiments are sometimes inelastic.

State what is meant by an inelastic collision.

(1)

.....

**(Total for question = 6 marks)**



**Q9.**

At the beginning of the 20th century, Rutherford carried out large-angle alpha particle scattering experiments using gold ( $^{197}_{79}\text{Au}$ ) foil.

The vast majority of the alpha particles went straight through the foil whilst a few were deflected straight back.

Rutherford also carried out the experiment with aluminium ( $^{27}_{13}\text{Al}$ ) foil.

The aluminium foil had the same thickness as the gold foil and the alpha particles had the same initial kinetic energy.

The following observations were made.

Observation 1:

The fraction of alpha particles scattered at any particular angle for aluminium foil was always much less than for gold foil.

Observation 2:

The alpha particles scattered from aluminium foil had less kinetic energy than the alpha particles scattered from gold foil.

Explain how these observations can be used to deduce how an aluminium nucleus compares to a gold nucleus.

(4)

.....

.....

.....

.....

.....

.....

.....

.....

.....

**(Total for question = 4 marks)**

**Q10.**

In the sport of curling, two teams of 'curlers' take turns sliding polished granite stones across an ice surface towards a circular target marked on the ice.



commons.wikimedia.org

\* Stone B is stationary. Stone A travels towards the target and makes a direct hit on stone B as shown. Both stones have mass  $m$ .

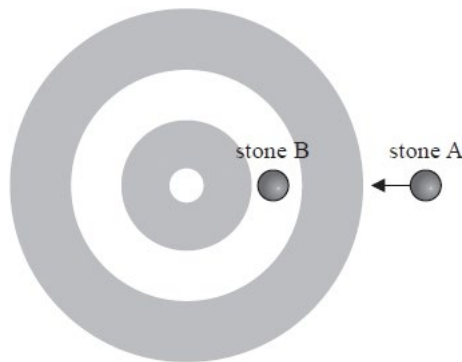

The collision is elastic. Just before the collision stone A has a velocity  $v$ . After the collision stone B moves off with velocity  $v$ .

Discuss how the relevant conservation laws apply to this collision.

(6)

.....

.....

.....

.....

.....

.....

.....

.....

.....

.....

.....

**(Total for question = 6 marks)**

**Q11.**

A bullet is fired into a block of wood. Select the line of the table that applies to this situation.

	<b>Collision</b>	<b>Kinetic energy</b>	<b>Momentum</b>
<input type="checkbox"/> <b>A</b>	elastic	conserved	conserved
<input type="checkbox"/> <b>B</b>	inelastic	not conserved	conserved
<input type="checkbox"/> <b>C</b>	elastic	conserved	not conserved
<input type="checkbox"/> <b>D</b>	inelastic	not conserved	not conserved

**(Total for question = 1 mark)**

## Mark Scheme - Impulse and Collisions in 2D

Q1.

Question Number	Acceptable answers	Additional guidance	Mark
	<p><b>The only correct answer is A</b></p> <p><i>B is not correct because these are base units of force</i></p> <p><i>C is not correct because these are not base units</i></p> <p><i>D is not correct because these are not base units</i></p>	$\text{kg m s}^{-1}$	<b>1</b>

Q2.

Question number	Acceptable answers	Additional guidance	Mark
(i)	<ul style="list-style-type: none"> <li>Use of <math>\frac{1}{2}mv^2 = mgh</math> (1)</li> <li><math>v = 2.43 \text{ m s}^{-1}</math> (1)</li> </ul>	<p>Example of calculation:</p> $v = \sqrt{2gh} = \sqrt{2 \times 9.81 \times 0.30} = 2.43 \text{ m s}^{-1}$	<b>2</b>
(ii)	<ul style="list-style-type: none"> <li>Use of impulse = change in momentum (1)</li> <li>Recognises initial velocity is zero (1)</li> <li>Hence <math>F = 0.923 \text{ N}</math> (1)</li> <li>Use of <math>l = \pi d</math> (1)</li> <li>Equates calculated value of <math>F</math> with <math>BlI</math> (1)</li> <li>Hence <math>I = 191 \text{ A}</math> (1)</li> </ul>	<p>Example of calculation:</p> $Ft = mv - mu \text{ where } u = 0$ <p>So <math>F = (0.019 \text{ kg} \times 2.43 \text{ m s}^{-1}) / 0.05 \text{ s} = 0.923 \text{ N}</math></p> $l = \pi \times 0.048 \text{ m} = 0.151 \text{ m}$ $I = 0.923 \text{ N} / (0.032 \text{ T} \times 0.151 \text{ m}) = 191 \text{ A}$	<b>6</b>

Q3.

Question Number	Acceptable answers	Additional guidance	Mark
	<ul style="list-style-type: none"> <li>Impulse is the product <math>Ft</math> which is area under this graph (1)</li> </ul>		<b>1</b>

## Q4.

Question Number	Acceptable Answer	Additional Guidance	Mark
<b>(a)</b>	<p>An explanation that makes reference to the following:</p> <ul style="list-style-type: none"> <li>• air molecules make collisions with the puck and transfer momentum to the puck (1)</li> <li>• according to Newton's 2nd law the change of momentum creates a force on the puck (1)</li> <li>• the rate of change of momentum by air molecules colliding with bottom of puck is greater than that due to the collisions on the top of the puck (1)</li> <li>• the net (upward) force balances the weight of the puck <u>OR</u> the greater air pressure below the puck allows the puck to be supported. (1)</li> </ul>		<b>(4)</b>

Question Number	Acceptable Answer	Additional Guidance	Mark				
* (b)	<p>This question assesses a student's ability to show a coherent and logically structured answer with linkages and fully-sustained reasoning.</p> <p>Marks are awarded for indicative content and for how the answer is structured and shows lines of reasoning.</p> <p>The following table shows how the marks should be awarded for indicative content.</p> <table border="1" data-bbox="427 786 791 1032"> <thead> <tr> <th data-bbox="427 786 603 981">Number of indicative marking points seen in answer</th> <th data-bbox="608 786 791 981">Number of marks awarded for indicative marking points</th> </tr> </thead> <tbody> <tr> <td data-bbox="427 981 603 1032">6</td> <td data-bbox="608 981 791 1032">4</td> </tr> </tbody> </table>	Number of indicative marking points seen in answer	Number of marks awarded for indicative marking points	6	4	<p>Guidance on how the mark scheme should be applied: The mark for indicative content should be added to the mark for lines of reasoning. For example, an answer with five indicative marking points which is partially structured with some linkages and lines of reasoning scores 4 marks (3 marks for indicative content and 1 mark for partial structure and some linkages and lines of reasoning). If there are no linkages between points, the same five indicative marking points would yield an overall score of 3 marks (3 marks for indicative content and no marks for linkages).</p>	
Number of indicative marking points seen in answer	Number of marks awarded for indicative marking points						
6	4						

5 - 4	3
3 - 2	2
1	1
0	0

The following table shows how the marks should be awarded for structure and lines of reasoning.

	Number of marks awarded for structure of answer and sustained line of reasoning
Answer shows a coherent and logical structure with linkages and fully sustained lines of reasoning demonstrated throughout	2
Answer is partially structured with some linkages and lines of reasoning	1
Answer has no linkages between points and is unstructured	0

	<p><b>Indicative content:</b></p> <ul style="list-style-type: none"> <li>• applying Newton's 3<sup>rd</sup> law one puck (A) exerts a force on the other puck (B) and vice versa (1)</li> <li>• forces equal in magnitude and opposite in direction (1)</li> <li>• forces act for same time (1)</li> <li>• <math>F\Delta t_A = -F\Delta t_B</math> (1)</li> <li>• applying Newton's 2<sup>nd</sup> law <math>F\Delta t = \Delta p</math> since <math>F</math> is a resultant force on each puck (1)</li> <li>• total change in momentum = zero, so momentum is conserved OR <math>\Delta p</math> for one puck = <math>-\Delta p</math> for the other puck, so momentum is conserved (1)</li> </ul>		<b>(6)</b>
--	---	--	------------

Question Number	Acceptable Answer	Additional Guidance	Mark
<b>(c)(i)</b>	<ul style="list-style-type: none"> <li>• resolve velocities to find forward/sideways component (1)</li> <li>• apply principle of conservation of momentum (1)</li> <li>• <math>v = 3.46 \text{ m s}^{-1}</math> (1)</li> </ul>	<p><u>Example of calculation:</u>                      Forwards velocity components:  <math>v \cos 30^\circ = 0.866 v</math>; <math>2 \cos 60^\circ = 1 \text{ m s}^{-1}</math>  <math>4m = m \times 0.866 v + m \times 1</math>  <math>\therefore v = \frac{(4-1)\text{ms}^{-1}}{0.866} = 3.46 \text{ m s}^{-1}</math></p>	<b>(3)</b>
<b>(c)(ii)</b>	<ul style="list-style-type: none"> <li>• use <math>KE = \frac{1}{2}mv^2</math> (1)</li> <li>• show that final KE is equal to initial KE (1)</li> <li>• elastic collisions conserve KE, so collision is elastic (1)</li> </ul>	<p><u>Example of calculation:</u>  <math>KE_i = \frac{1}{2}m \times 4^2 = 8m</math>  <math>KE_f = \frac{1}{2}m \times 3.46^2 + \frac{1}{2}m \times 2^2</math>  <math>= 6m + 2m = 8m</math></p>	<b>(3)</b>



Q5.

Question Number	Acceptable answers	Additional guidance	Mark
	<p><b>The only correct answer is B</b></p> <p><i>A is not correct because this is not dimensionally correct</i></p> <p><i>C is not correct because <math>E_k/2p = v/4</math></i></p> <p><i>D is not correct because this is not dimensionally correct</i></p>		<b>1</b>

Q6.

Question Number	Answer	Mark
	B	<b>1</b>

Q7.

Question Number	Acceptable answers	Additional guidance	Mark
(i)	<ul style="list-style-type: none"> <li>• Use of momentum = <math>mv</math> (1)</li> <li>• See component(s) in x direction (1)</li> <li>• Uses momentum conservation (1)</li> <li>• <math>u = 1.6 \text{ (m s}^{-1}\text{)}</math> (1)</li> </ul>	Example of calculation: $7.1(\text{g})u = 7.1(\text{g}) \times 0.9(\text{ms}^{-1}) \times \cos 8$ $+ 3.6(\text{g}) \times 1.4(\text{ms}^{-1}) \times \cos 10$ $u = \frac{(6.33 + 4.96)}{7.1}$ $u = 1.59\text{ms}^{-1}$	<b>(4)</b>

Question Number	Acceptable answers	Additional guidance	Mark
(ii)	<ul style="list-style-type: none"> <li>• Use of <math>E_k = \frac{1}{2} mv^2</math> (1)</li> <li>• Value of Initial <math>E_k = 9.0 \times 10^{-3} \text{ (J)}</math> and (1)                              Final <math>E_k = 6.4 \times 10^{-3} \text{ (J)}</math>                              (Show that value gives Initial <math>E_k = 1.42 \times 10^{-2} \text{ (J)}</math> allow ecf from (b)(i))</li> </ul>	Allow ecf from b(i)  Example of calculation: Initial $E_k = \frac{1}{2} \times 7.1 \times 10^{-3} (\text{kg}) \times 1.59^2 (\text{ms}^{-1})^2 = 9.0 \times 10^{-3} \text{ J}$ Final $E_k = \frac{1}{2} \times 7.1 \times 10^{-3} \times 0.9^2 + \frac{1}{2} \times 3.6 \times 10^{-3} \times 1.4^2 = 6.4 \times 10^{-3} \text{ J}$	<b>(2)</b>

Q8.

Question Number	Acceptable answers	Additional guidance	Mark
(i)	<ul style="list-style-type: none"> <li>units eV (energy) base units: <math>\text{kg m}^2 \text{s}^{-2}</math> Or base units of momentum: <math>\text{kg m s}^{-1}</math></li> </ul> <p>(1)</p> <ul style="list-style-type: none"> <li>divide energy by units of speed (c) <math>\text{m s}^{-1}</math> gives <math>\text{kg m s}^{-1}</math> which are units of momentum Or multiply units of momentum by speed (c) <math>\text{m s}^{-1}</math> to give units of energy <math>\text{kg m}^2 \text{s}^{-2}</math></li> </ul> <p>(1)</p>		2
(ii)	<ul style="list-style-type: none"> <li>resolves a y-component or x-component of electron momentum</li> </ul> <p>(1)</p> <ul style="list-style-type: none"> <li>applies momentum conservation in x-direction or y-direction</li> </ul> <p>(1)</p> <ul style="list-style-type: none"> <li>comparison of total momentum after Or momentum of proton after plus comment</li> </ul> <p>(1)</p> <p>Alternative:</p> <ul style="list-style-type: none"> <li>draws a vector triangle</li> </ul>	<p><u>Example of calculation</u></p> $p_y = 9.1 (\text{GeV}/c)\sin 20 = 3.1 \text{ GeV}/c$ $p_x = 9.1 (\text{GeV}/c)\cos 20 = 8.55 \text{ GeV}/c$ <p><math>p_x</math> of proton</p> $= 20 (\text{GeV}/c) - 8.55 (\text{GeV}/c) = 11.45 \text{ GeV}/c$ $p_{\text{proton}} = \sqrt{3.1^2 + 11.45^2}$ $= 11.86 \text{ GeV}/c$ <p>Alternative:</p> $p_y = 9.1 (\text{GeV}/c)\sin 20 = 3.1 \text{ GeV}/c = 11.9 (\text{GeV}/c)\sin \theta$ $\theta = 15.2$ <p>So total <math>p</math> after = <math>11.9 \text{ GeV}/c \cos 15.2 + 9.1 (\text{GeV}/c)\cos 20</math></p>	3
	<ul style="list-style-type: none"> <li>Uses cosine rule</li> <li>Calculates angle from three sides = <math>20.4^\circ</math></li> </ul>	$= 11.5 + 8.55 = 20.05 \text{ GeV}/c$	
(iii)	<ul style="list-style-type: none"> <li>(total) kinetic energy not conserved</li> </ul> <p>(1)</p>		1

Q9.

Question Number	Acceptable answers	Additional guidance	Mark
	<p>An explanation that makes reference to the following points:</p> <p>Observation 1</p> <ul style="list-style-type: none"> <li>• (the fraction of alpha scattering is less for aluminium) (1) so the force of repulsion is less (at a given distance)</li> <li>• therefore the charge on an aluminium nucleus is less than on gold nucleus (1)</li> </ul> <p>Observation 2</p> <ul style="list-style-type: none"> <li>• (the <math>E_k</math> is less for scattered alpha for aluminium) so recoiling nucleus must have some/more kinetic energy (1)</li> <li>• The mass of an aluminium nucleus is less than mass of a gold nucleus (1)</li> </ul>		<b>4</b>

**Q10.**

Question Number	Acceptable Answer	Additional Guidance																																									
	<p>This question assesses a student’s ability to show a coherent and logically structured answer with linkages and fully sustained reasoning.</p> <p>Marks are awarded for indicative content and for how the answer is structured and shows lines of reasoning.</p> <p>The table shows how the marks should be awarded for indicative content and lines of reasoning.</p> <table border="1" style="margin-left: auto; margin-right: auto;"> <thead> <tr> <th>IC points</th> <th>IC mark</th> <th>Max linkage mark available</th> <th>Max final mark</th> </tr> </thead> <tbody> <tr><td>6</td><td>4</td><td>2</td><td>6</td></tr> <tr><td>5</td><td>3</td><td>2</td><td>5</td></tr> <tr><td>4</td><td>3</td><td>1</td><td>4</td></tr> <tr><td>3</td><td>2</td><td>1</td><td>3</td></tr> <tr><td>2</td><td>2</td><td>0</td><td>2</td></tr> <tr><td>1</td><td>1</td><td>0</td><td>1</td></tr> <tr><td>0</td><td>0</td><td>0</td><td>0</td></tr> </tbody> </table>	IC points	IC mark	Max linkage mark available	Max final mark	6	4	2	6	5	3	2	5	4	3	1	4	3	2	1	3	2	2	0	2	1	1	0	1	0	0	0	0		<table border="1"> <tr> <td></td> <td style="text-align: center;">Number of marks awarded for structure of answer and sustained line of reasoning</td> </tr> <tr> <td>Answer shows a coherent and logical structure with linkage and fully sustained lines of reasoning demonstrated throughout</td> <td style="text-align: center;">2</td> </tr> <tr> <td>Answer is partially structured with some linkages and lines of reasoning</td> <td style="text-align: center;">1</td> </tr> <tr> <td>Answer has no linkages between its points and is unstructured</td> <td style="text-align: center;">0</td> </tr> </table>		Number of marks awarded for structure of answer and sustained line of reasoning	Answer shows a coherent and logical structure with linkage and fully sustained lines of reasoning demonstrated throughout	2	Answer is partially structured with some linkages and lines of reasoning	1	Answer has no linkages between its points and is unstructured	0
IC points	IC mark	Max linkage mark available	Max final mark																																								
6	4	2	6																																								
5	3	2	5																																								
4	3	1	4																																								
3	2	1	3																																								
2	2	0	2																																								
1	1	0	1																																								
0	0	0	0																																								
	Number of marks awarded for structure of answer and sustained line of reasoning																																										
Answer shows a coherent and logical structure with linkage and fully sustained lines of reasoning demonstrated throughout	2																																										
Answer is partially structured with some linkages and lines of reasoning	1																																										
Answer has no linkages between its points and is unstructured	0																																										

	<p>Indicative content:</p> <ul style="list-style-type: none"> <li>• (Collision takes place on an ice surface so) there is minimal friction Or External forces are negligible</li> <li>• Momentum is conserved in the collision</li> <li>• The momentum of stone A before the collision equals the momentum of (A and) B after the collision</li> <li>• Stone A must be at rest after the collision</li> <li>• All of the kinetic energy of stone A must have been transferred to stone B</li> <li>• Kinetic energy is conserved in an elastic collision</li> </ul>		6
--	--	--	---

**Q11.**

Question number	Acceptable answers	Additional guidance	Mark
	B		1