

Electrical Circuits and Internal Resistance

Q1.

Part of an electric circuit is shown.

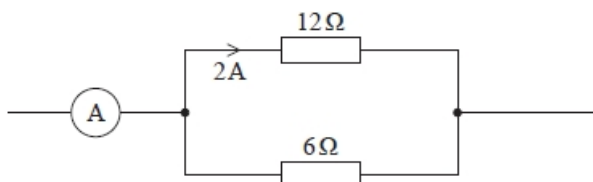

What is the current shown by the ammeter?

- A 3 A
- B 4 A
- C 5 A
- D 6 A

(Total for question = 1 mark)

Q2.

The diagram shows a combination of three identical resistors.

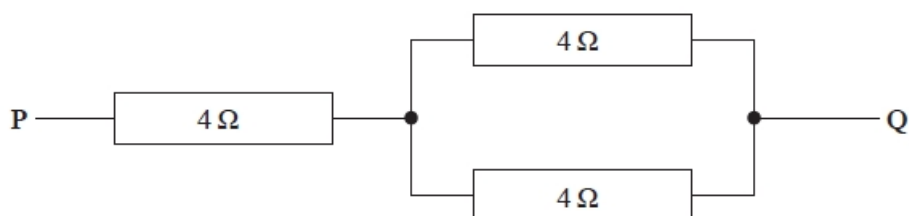

What is the combined resistance between P and Q?

- A $4\ \Omega$
- B $6\ \Omega$
- C $8\ \Omega$
- D $12\ \Omega$

(Total for question = 1 mark)

Q3.

The diagram represents a resistor of resistance R in a series circuit with a cell of e.m.f. ε and internal resistance r .

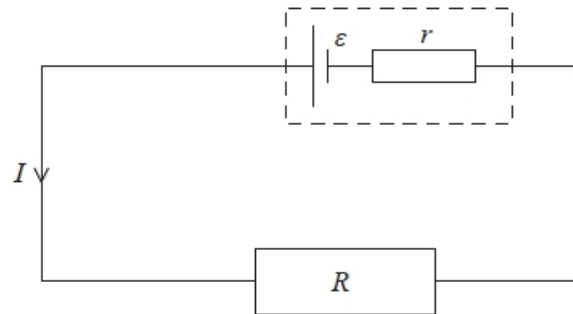

Which of the following correctly gives the potential difference V across the internal resistance?

- A $V = \frac{\varepsilon(R+r)}{r}$
- B $V = \frac{\varepsilon R}{R+r}$
- C $V = \frac{\varepsilon(R+r)}{R}$
- D $V = \frac{\varepsilon r}{(R+r)}$

(Total for question = 1 mark)

Q4.

The diagram shows a potential divider circuit that contains a negative temperature coefficient thermistor.

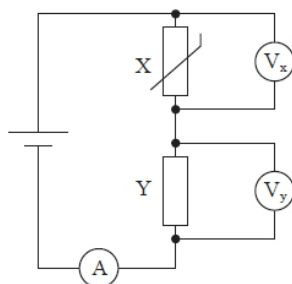

The temperature of the room containing the circuit increases.

Select the row of the table that correctly shows the changes in readings on the meters.

	V_x	V_y	A
<input type="checkbox"/> A	decrease	increase	decrease
<input type="checkbox"/> B	decrease	increase	increase
<input type="checkbox"/> C	increase	decrease	decrease
<input type="checkbox"/> D	increase	decrease	increase

(Total for question = 1 mark)

Q5.

A student is deriving an equation for the total resistance of resistors in series.

She writes the following steps but does not justify them.

Step 1 $V = V_1 + V_2$

Step 2 *but* $V = IR$

Step 3 *so* $IR = I_1R_1 + I_2R_2$

Step 4 *but* $I = I_1 = I_2$

Step 5 *Therefore* $R = R_1 + R_2$

Which step is justified using conservation of charge?

(1)

- A Step 1
- B Step 2
- C Step 3
- D Step 4

(Total for question = 1 mark)

Q6.

A student carried out an experiment to determine the electromotive force (e.m.f.) of a cell. The current in a circuit was changed by adjusting a variable resistor. A graph was plotted of the voltmeter reading on the y-axis against the ammeter reading on the x-axis.

Using the data obtained, the value of the intercept on the y-axis was the e.m.f. of the cell.

Which of the following circuits should have been used?

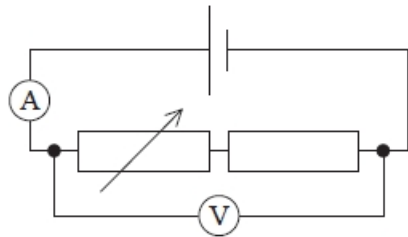

A

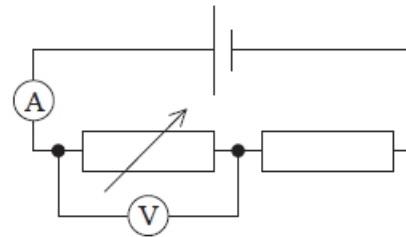

B

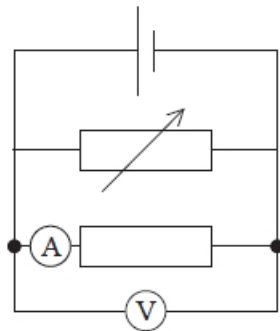

C

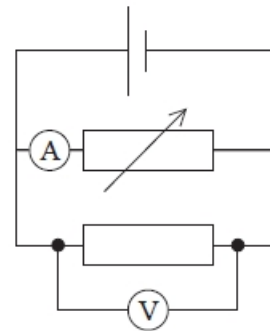

D

- A**
- B**
- C**
- D**

(Total for question = 1 mark)

Q7.

A potential difference, V , is applied to two resistors in parallel, each of resistance R . A current, I , flows through the whole circuit.

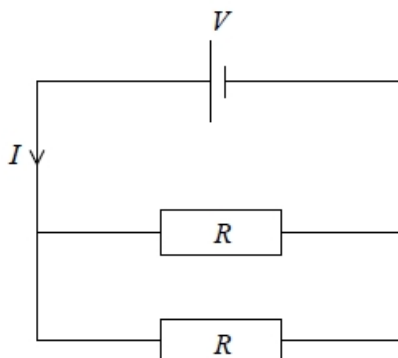

The correct expression for the power developed in each resistor is given by

- A** $P = IV$
- B** $P = IV/4$
- C** $P = V^2/2R$
- D** $P = I^2R/4$

(Total for question = 1 mark)

Q8.

A cell of e.m.f ϵ and internal resistance r is connected across a fixed resistor of resistance R . There is a current I in the circuit and a potential difference V across the fixed resistor.

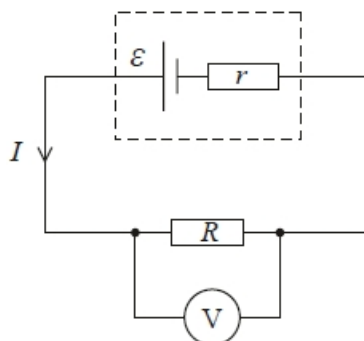

The term 'lost volts' refers to the difference between the e.m.f. and the terminal potential difference.

Which of the following is an expression for the lost volts?

- A $I(R + r)$
- B Ir
- C IR
- D $I(R - r)$

(Total for question = 1 mark)

Q9.

A cell of e.m.f. ϵ and internal resistance r is connected across a variable resistor as shown.

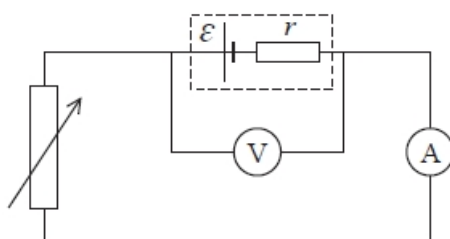

A student varied the current in the circuit using the variable resistor. The current I and the corresponding potential difference V across the cell were recorded. A graph was plotted of V against I .

Which of the following statements about the graph is correct?

	Gradient	Intercept on y -axis
<input type="checkbox"/> A	positive	r
<input type="checkbox"/> B	positive	ϵ
<input type="checkbox"/> C	negative	r
<input type="checkbox"/> D	negative	ϵ

(Total for question = 1 mark)

Q10.

A cell of e.m.f. ε and internal resistance r is connected across an external resistor of resistance R .

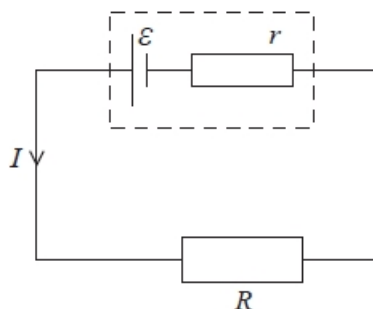

Which is the correct expression for the terminal potential difference V of the cell?

- A** $V = \varepsilon + Ir$
- B** $V = \varepsilon - Ir$
- C** $V = \varepsilon + IR$
- D** $V = \varepsilon - IR$

(Total for question = 1 mark)

Q11.

When a light dependent resistor is illuminated, its resistance falls from $1000\text{ k}\Omega$ to $0.1\text{ k}\Omega$.

The light dependent resistor is connected in series with a fixed resistor.

Which of the circuits shown would produce the greatest output potential difference V_{out} when illuminated?

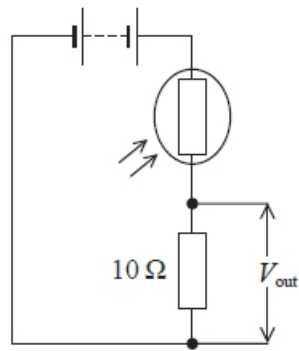

A

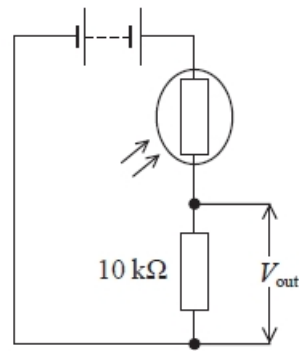

B

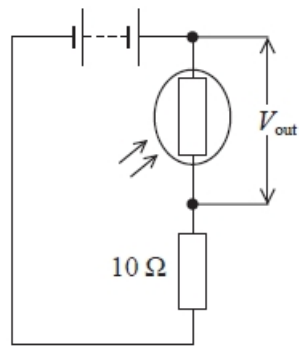

C

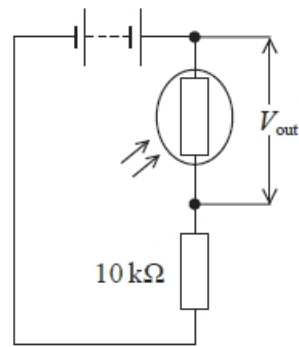

D

(Total for question = 1 mark)

Q12.

A cell of e.m.f. 1.5 V is connected to a 5.0 Ω resistor. The terminal potential difference across the cell is 1.0 V.

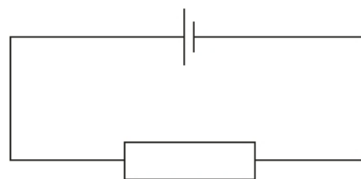

Which of the following is the current in the circuit?

- A 0.1 A
- B 0.2 A
- C 0.3 A
- D 0.5 A

(Total for question = 1 mark)

Q13.

Two resistors of resistance R_1 and R_2 are connected to a battery as shown. The terminal potential difference of the battery is V .

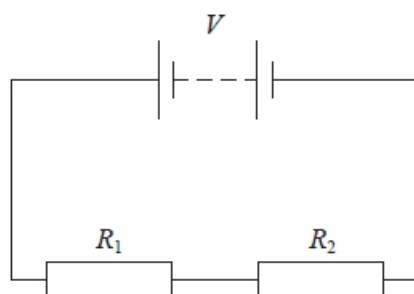

Which of the following gives the potential difference across the resistor of resistance R_1 ?

- A $\frac{R_1}{R_2} \times V$
- B $\frac{R_1}{R_1 + R_2} \times V$
- C $\frac{R_2}{R_1} \times V$
- D $\frac{R_2}{R_1 + R_2} \times V$

(Total for question = 1 mark)

Q14.

Two resistors are connected in parallel and the current in one of them is 2.0 A, as shown.

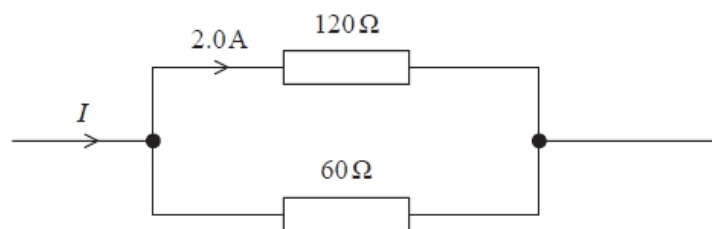

Which of the following is the total resistance of the resistors in parallel?

- A 20Ω
- B 40Ω
- C 90Ω
- D 180Ω

(Total for question = 1 mark)

Mark Scheme - Electrical Circuits and Internal Resistance

Q1.

Question Number	Acceptable answers	Additional guidance	Mark
	<p>The only correct answer is D</p> <p><i>A is not correct because as it is $2A + 1A$</i></p> <p><i>B is not correct because $2A + 2A$</i></p> <p><i>C is not correct because $2A + 3A$</i></p>	6 A	1

Q2.

Question Number	Answer	Mark
	B	1

Q3.

Question Number	Answer	Mark
	D	1

Q4.

Question Number	Answer	Mark
	B	1

Q5.

Question Number	Answer	Mark
	<p>D Step 4</p> <p>Incorrect Answers:</p> <p>A – this step uses the conservation of energy</p> <p>B – this step is just a statement of Ohm's law</p> <p>C – this step uses the conservation of energy</p>	1

Q6.

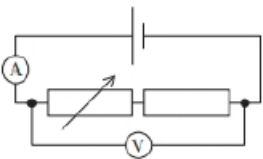
Question Number	Answer	Mark
	<p>A</p> 	1
	<p>Incorrect Answers: B – the ammeter would measure the current in the cell, but the voltmeter would not be measuring the p.d. across the cell C – the voltmeter would measure the p.d. across the cell but the ammeter would not be measuring the current in the cell D – the voltmeter would measure the p.d. across the cell but the ammeter would not be measuring the current in the cell</p>	

Q7.

Question number	Acceptable answers	Additional guidance	Mark
	D		1

Q8.

Question Number	Acceptable answers	Additional guidance	Mark
	B		1

Q9.

Question Number	Answers	Additional Guidance	Mark				
	D	<table border="1"> <thead> <tr> <th>Gradient</th> <th>Intercept on y-axis</th> </tr> </thead> <tbody> <tr> <td>negative</td> <td>ϵ</td> </tr> </tbody> </table>	Gradient	Intercept on y-axis	negative	ϵ	(1)
Gradient	Intercept on y-axis						
negative	ϵ						

Q10.

Question Number	Acceptable Answer	Additional guidance	Mark
	B	$V = \epsilon - Ir$	(1)

Q11.

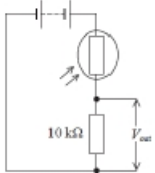
Question Number	Answers	Additional Guidance	Mark
	B		(1)

Q12.

Question Number	Acceptable answers	Additional guidance	Mark
	B		1

Q13.

Question Number	Answer	Additional Guidance	Mark
	B is the only correct answer	A is incorrect because this does not give the correct ratio C is incorrect because this does not give the correct ratio D is incorrect because this does not give the correct ratio	1

Q14.

Question Number	Acceptable answers	Additional guidance	Mark
	The only correct answer is B A is not correct as $120 \Omega / 3 = 40 \Omega$ C is not correct as $120 \Omega / 3 = 40 \Omega$ D is not correct as $120 \Omega / 3 = 40 \Omega$		1