

## Argand Diagrams

### Questions

**Q1.**

(a) Shade on an Argand diagram the set of points

$$\left\{ z \in \mathbb{C} : |z - 1 - i| \leq 3 \right\} \cap \left\{ z \in \mathbb{C} : \frac{\pi}{4} \leq \arg(z - 2) \leq \frac{3\pi}{4} \right\} \quad (5)$$

The complex number  $w$  satisfies

$$|w - 1 - i| = 3 \text{ and } \arg(w - 2) = \frac{\pi}{4}$$

(b) Find, in simplest form, the exact value of  $|w|^2$

(4)

**(Total for question = 9 marks)**

**Q2.**

Given that there are two distinct complex numbers  $z$  that satisfy

$$\left\{ z : |z - 3 - 5i| = 2r \right\} \cap \left\{ z : \arg(z - 2) = \frac{3\pi}{4} \right\}$$

determine the exact range of values for the real constant  $r$ .

**(Total for question = 7 marks)**

**Q3.**

(a) Shade on an Argand diagram the set of points

$$\left\{ z \in \mathbb{C} : |z - 4i| \leq 3 \right\} \cap \left\{ z \in \mathbb{C} : -\frac{\pi}{2} < \arg(z + 3 - 4i) \leq \frac{\pi}{4} \right\}$$

(6)

The complex number  $w$  satisfies

$$|w - 4i| = 3$$

(b) Find the maximum value of  $\arg w$  in the interval  $(-\pi, \pi]$ .

Give your answer in radians correct to 2 decimal places.

(2)

**(Total for question = 8 marks)**

**Q4.**

$$f(z) = z^3 + z^2 + pz + q$$

where  $p$  and  $q$  are real constants.

The equation  $f(z) = 0$  has roots  $z_1$ ,  $z_2$  and  $z_3$

When plotted on an Argand diagram, the points representing  $z_1$ ,  $z_2$  and  $z_3$  form the vertices of a triangle of area 35

Given that  $z_1 = 3$ , find the values of  $p$  and  $q$ .

(7)

**(Total for question = 7 marks)**

**Q5.**

$$f(z) = z^3 + az + 52 \quad \text{where } a \text{ is a real constant}$$

Given that  $2 - 3i$  is a root of the equation  $f(z) = 0$

(a) write down the other complex root.

(1)

(b) Hence

(i) solve completely  $f(z) = 0$

(ii) determine the value of  $a$

(4)

(c) Show all the roots of the equation  $f(z) = 0$  on a single Argand diagram.

(1)

**(Total for question = 6 marks)**

**Q6.**

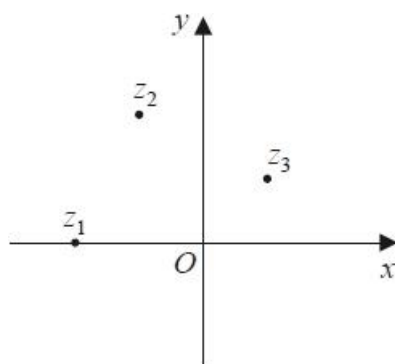

**Figure 1**

The complex numbers  $z_1 = -2$ ,  $z_2 = -1 + 2i$  and  $z_3 = 1 + i$  are plotted in Figure 1, on an Argand diagram for the complex plane with  $z = x + iy$

(a) Explain why  $z_1$ ,  $z_2$  and  $z_3$  cannot all be roots of a quartic polynomial equation with real coefficients.

(2)

(b) Show that  $\arg \left( \frac{z_2 - z_1}{z_3 - z_1} \right) = \frac{\pi}{4}$

(3)

(c) Hence show that  $\arctan(2) - \arctan\left(\frac{1}{3}\right) = \frac{\pi}{4}$

(2)

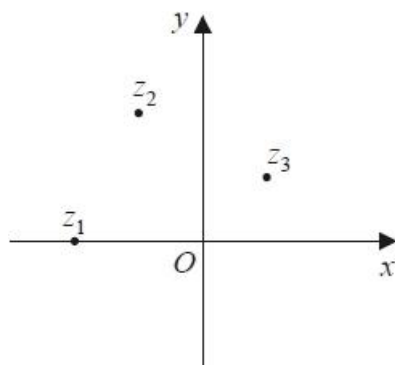

**Diagram 1**

(d) Shade, on Diagram 1, the set of points of the complex plane that satisfy the inequality

$$|z + 2| \leq |z - 1 - i|$$

(2)

**(Total for question = 9 marks)**

**Q7.**

(a) Express the complex number  $w = 4\sqrt{3} - 4i$  in the form  $r(\cos\theta + i\sin\theta)$  where  $r > 0$  and  $-\pi < \theta \leq \pi$

(4)

(b) Show, on a single Argand diagram,

(i) the point representing  $w$

(ii) the locus of points defined by  $\arg(z + 10i) = \frac{\pi}{3}$

(3)

(c) Hence determine the minimum distance of  $w$  from the locus  $\arg(z + 10i) = \frac{\pi}{3}$

(3)

**(Total for question = 10 marks)**

Q8.

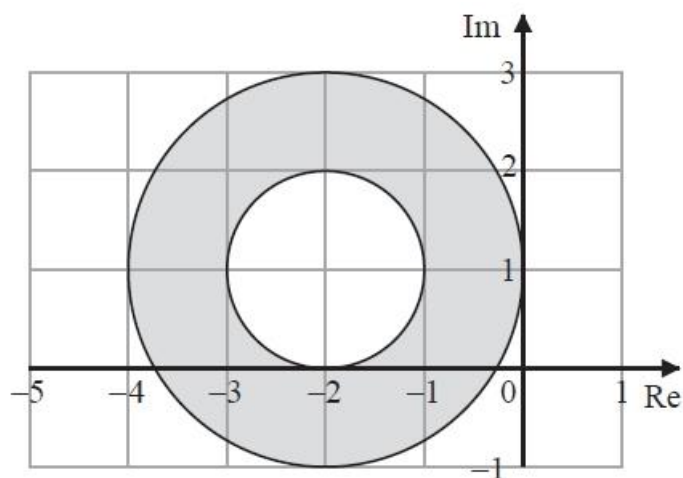

Figure 1

Figure 1 shows an Argand diagram.

The set  $P$ , of points that lie within the shaded region including its boundaries, is defined by

$$P = \{z \in \mathbb{C} : a \leq |z + b + ci| \leq d\}$$

where  $a$ ,  $b$ ,  $c$  and  $d$  are integers.

(a) Write down the values of  $a$ ,  $b$ ,  $c$  and  $d$ .

(3)

The set  $Q$  is defined by

$$Q = \{z \in \mathbb{C} : a \leq |z + b + ci| \leq d\} \cap \{z \in \mathbb{C} : |z - i| \leq |z - 3i|\}$$

(b) Determine the exact area of the region defined by  $Q$ , giving your answer in simplest form.

(7)

**(Total for question = 10 marks)**

**Q9.**

$$f(z) = z^4 + az^3 + bz^2 + cz + d$$

where  $a$ ,  $b$ ,  $c$  and  $d$  are real constants.

Given that  $-1 + 2i$  and  $3 - i$  are two roots of the equation  $f(z) = 0$

(a) show all the roots of  $f(z) = 0$  on a single Argand diagram,

(4)

(b) find the values of  $a$ ,  $b$ ,  $c$  and  $d$ .

(5)

**(Total for question = 9 marks)**

**Q10.**

$$f(z) = z^4 + az^3 + bz^2 + cz + d$$

where  $a$ ,  $b$ ,  $c$  and  $d$  are real constants.

The equation  $f(z) = 0$  has complex roots  $z_1$ ,  $z_2$ ,  $z_3$  and  $z_4$

When plotted on an Argand diagram, the points representing  $z_1$ ,  $z_2$ ,  $z_3$  and  $z_4$  form the vertices of a square, with one vertex in each quadrant.

Given that  $z_1 = 2 + 3i$ , determine the values of  $a$ ,  $b$ ,  $c$  and  $d$ .

**(Total for question = 6 marks)**

**Q11.**

Given that

$$\begin{aligned}z_1 &= 2 + 3i \\|z_1 z_2| &= 39\sqrt{2} \\ \arg(z_1 z_2) &= \frac{\pi}{4}\end{aligned}$$

where  $z_1$  and  $z_2$  are complex numbers,

(a) write  $z_1$  in the form  $r(\cos \theta + i \sin \theta)$

Give the exact value of  $r$  and give the value of  $\theta$  in radians to 4 significant figures.

(2)

(b) Find  $z_2$  giving your answer in the form  $a + ib$  where  $a$  and  $b$  are integers.

(6)

**(Total for question = 8 marks)**



**Mark Scheme – Argand Diagrams**

Q1.

Question	Scheme	Marks	AOs
(a)		M1	1.1b
		M1	1.1b
		A1	2.2a
		M1	3.1a
		A1	1.1b
		(5)	
(b)	$(x-1)^2 + (y-1)^2 = 9, y = x - 2 \Rightarrow x = \dots, \text{ or } y = \dots$	M1	3.1a
	$x = 2 + \frac{\sqrt{14}}{2}, y = \frac{\sqrt{14}}{2}$	A1	1.1b
	$ w ^2 = \left(2 + \frac{\sqrt{14}}{2}\right)^2 + \left(\frac{\sqrt{14}}{2}\right)^2$	M1	1.1b
	$= 11 + 2\sqrt{14}$	A1	1.1b
		(4)	

**(9 marks)****Notes**

(a)

M1: Circle or arc of a circle with centre in first quadrant and with the circle in all 4 quadrants or arc of circle in quadrants 1 and 2

M1: A “V” shape i.e. with both branches above the  $x$ -axis and with the vertex on the positive real axis. Ignore any branches below the  $x$ -axis.

A1: Two half lines that meet on the positive real axis where the right branch intersects the circle or arc of a circle in the first quadrant and the left branch intersects the circle or arc of a circle in the second quadrant but not on the  $y$ -axis.

M1: Shades the region between the half-lines and within the circle

A1: Cso. A fully correct diagram including 2 marked (or implied by ticks) at the vertex on the real axis with the correct region shaded and all the previous marks scored.

(b)

M1: Identifies a suitable strategy for finding the  $x$  or  $y$  coordinate of the point of intersection.

Look for an attempt to solve equations of the form  $(x \pm 1)^2 + (y \pm 1)^2 = 9$  or 3 and  $y = \pm x \pm 2$

A1: Correct coordinates for the intersection (there may be other points but allow this mark if the correct coordinates are seen). (The correct coordinates may be implied by subsequent work.)

Allow equivalent exact forms and allow as a complex number e.g.  $2 + \frac{\sqrt{14}}{2} + \frac{\sqrt{14}}{2}i$

M1: Correct use of Pythagoras on their coordinates (There must be no  $i$ 's)

A1: Correct exact value by cso

Note that solving  $(x-1)^2 + (y-1)^2 = 9, y = x + 2$  gives  $x = \frac{\sqrt{14}}{2}, y = 2 + \frac{\sqrt{14}}{2}$  and hence the

correct answer fortuitously so scores M1A0M1A0

## Ch.2 Argand Diagrams

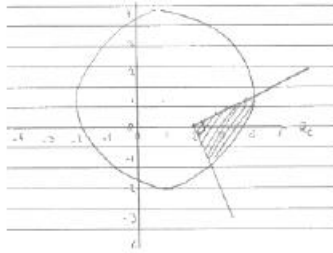

M1: Circle with centre in first quadrant  
 M0: The branches of the "V" must be above the x-axis  
 A0: Follows M0  
 M1: Shades the region between the half-lines and within the circle  
 A0: Depends on all previous marks

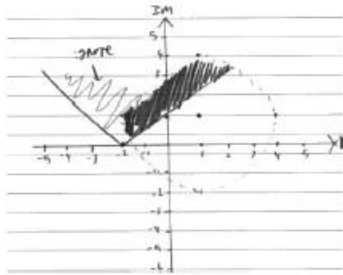

M1: Circle with centre in first quadrant  
 M0: The vertex of the "V" must be on the positive x-axis  
 A0: Follows M0  
 M1: Shades the region between the half-lines and within the circle (BOD)  
 A0: Depends on all previous marks

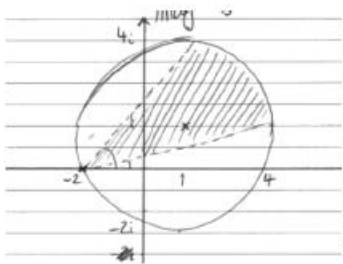

M1: Circle with centre in first quadrant  
 M0: The vertex of the "V" must be on the positive x-axis  
 A0: Follows M0  
 M1: Shades the region between the half-lines and within the circle  
 A0: Depends on all previous marks

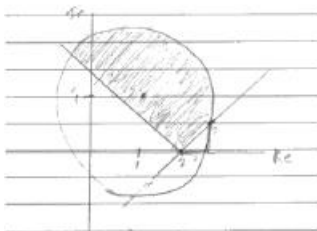

M1: Circle with centre in first quadrant  
 M1: A "V" shape i.e. with both branches above the x-axis and with the vertex on the positive real axis. Ignore any branches below the x-axis.  
 A1: Two half lines that meet on the positive real axis where the right branch intersects the circle in the first quadrant and the left branch intersects the circle in the second quadrant.  
 M1: Shades the region between the half-lines and within the circle  
 A1: A fully correct diagram including 2 marked at the vertex on the real axis with the correct region shaded and all the previous marks scored.

Q2.

Question	Scheme	Marks	AOs
	$(x-3)^2 + (y-5)^2 = (2r)^2$ and $y = -x + 2$	B1	1.1b
	$(x-3)^2 + (-x+2-5)^2 = (2r)^2$ or $(-y+2-3)^2 + (y-5)^2 = (2r)^2$	M1	3.1a
	$2x^2 + 18 - 4r^2 = 0$ or $2y^2 - 8y + 26 - 4r^2 = 0$	A1	1.1b
	$b^2 - 4ac > 0 \Rightarrow 0^2 - 4(2)(18 - 4r^2) > 0 \Rightarrow r > \dots$ or $x^2 = 9 - 2r^2 \Rightarrow 9 - 2r^2 > 0 \Rightarrow r > \dots$ or $b^2 - 4ac > 0 \Rightarrow (-8)^2 - 4(2)(26 - 4r^2) > 0 \Rightarrow r > \dots$	dM1	3.1a
	Finds a maximum value for $r$ $(2r)^2 = 5^2 + (3-2)^2 \Rightarrow r = \dots$	M1	3.1a
	$\frac{3\sqrt{2}}{2} < r < \frac{\sqrt{26}}{2}$ o.e.	A1 A1	1.1b 1.1b
	<b>Alternative</b> Using a circle with centre (3, 5) and radius $2r$ and $y = -x + 2$	B1	1.1b
	$y - 5 = 1(x - 3) \Rightarrow y = x + 2$ $x + 2 = -x + 2 \Rightarrow x = \dots$	M1	3.1a
	(0, 2)	A1	1.1b
	$2r > \sqrt{(3-0)^2 + (5-2)^2} \Rightarrow r > \dots$	dM1	3.1a
	Finds a maximum value for $r$ $(2r)^2 = 5^2 + (3-2)^2 \Rightarrow r = \dots$	M1	3.1a
	$\frac{3\sqrt{2}}{2} < r < \frac{\sqrt{26}}{2}$ o.e.	A1 A1	1.1b 1.1b
		(7)	
(7 marks)			

<p><b>Notes:</b></p> <p><b>B1:</b> Correct equations for each loci of points  <b>M1:</b> A complete method to find a 3TQ involving one variable using equations of the form <math>(x \pm 3)^2 + (y \pm 5)^2 = (2r)^2</math> or <math>2r^2</math> or <math>r^2</math> and <math>y = \pm x \pm 2</math>  <b>A1:</b> Correct quadratic equation</p>
<p><b>dM1:</b> Dependent on previous method mark. A complete method uses <math>b^2 - 4ac &gt; 0</math> or rearranges to find <math>x^2 = f(r)</math> and uses <math>f(r) &gt; 0</math> to the minimum value of <math>r</math>.  <b>M1:</b> Realises there will be an upper limit for <math>r</math> and uses Pythagoras theorem  <math>(2r)^2 = (y \text{ coord of centre})^2 + (x \text{ coord of centre} - 2)^2</math>  condone <math>(r)^2 = (y \text{ coord of centre})^2 + (x \text{ coord of centre} - 2)^2</math>  <b>A1:</b> One correct limit, either <math>\frac{3\sqrt{2}}{2} &lt; r</math> or <math>r &lt; \frac{\sqrt{26}}{2}</math> o.e.  <b>A1:</b> Fully correct inequality</p>
<p><b>Alternative</b></p> <p><b>B1:</b> Using a circle with centre (3, 5) and radius <math>2r</math> and <math>y = -x + 2</math>  <b>M1:</b> A complete method to find the point of intersection of the line <math>y = \pm x \pm 2</math> and circle where the line is a tangent to the circle.  <b>A1:</b> Correct point of intersection  <b>dM1:</b> Finds the distance between the point of intersection and the centre and uses this to find the minimum value of <math>r</math>. Condone radius of <math>r</math>.  <b>M1:</b> Realises there will be an upper limit for <math>r</math> and uses Pythagoras theorem  <math>(2r)^2 = (y \text{ coord of centre})^2 + (x \text{ coord of centre} - 2)^2</math>  <b>A1:</b> One correct limit, either <math>\frac{3\sqrt{2}}{2} &lt; r</math> or <math>r &lt; \frac{\sqrt{26}}{2}</math> o.e.  <b>A1:</b> Fully correct inequality</p>

Q3.

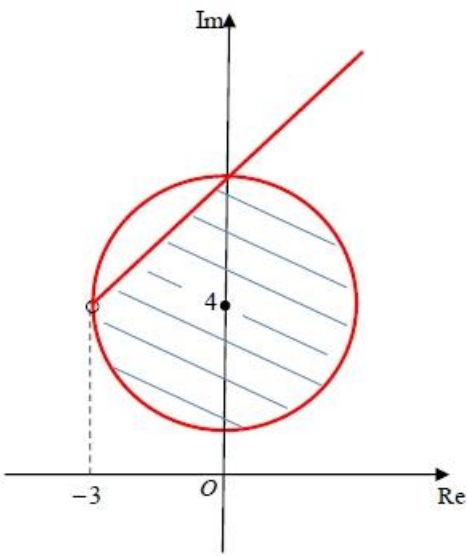
Question	Scheme		Marks	AOs
(a)			M1	1.1b
			A1	1.1b
			M1	1.1b
			A1	2.2a
			M1	3.1a
			A1	1.1b
			(6)	
(b)	$(\arg w)_{\max} = \frac{\pi}{2} + \arcsin\left(\frac{3}{4}\right)$		M1	3.1a
	$= 2.42 \text{ (2dp) cao}$		A1	1.1b
			(2)	
				<b>(8 marks)</b>
<b>Question Notes</b>				
(a)	M1	Circle.		
	A1	Centre (0, 4) and above the real axis.		
	M1	Half-line.		
	A1	(-3, 4) positioned correctly and the half-line intersects the top of the circle on the y-axis.		
	M1	Depends on both previous M marks Shades in a region inside the circle and below the half line.		
(b)	A1	Cso		
	Note	Final A1 mark is dependent on all previous marks being scored in part (a).		
	M1	Uses trigonometry to give an expression for an angle in the range $\left(\frac{\pi}{2}, \pi\right)$ or $(90^\circ, 180^\circ)$ .		
	A1	2.42 cao		



Q4.

Question	Scheme	Marks	AOs
	Complex roots are e.g. $\alpha \pm \beta i$ or $(z^3 + z^2 + pz + q) \div (z - 3) = z^2 + 4z + p + 12$ or $f(3) = 0 \Rightarrow 3^3 + 3^2 + 3p + q = 0$ or One of: $3 + z_2 + z_3 = -1$ , $3z_2z_3 = -q$ , $3z_2 + 3z_3 + z_2z_3 = p$	B1	3.1a
	Sum of roots $\alpha + \beta i + \alpha - \beta i + 3 = -1 \Rightarrow \alpha = \dots$ or $\alpha + \beta i + \alpha - \beta i = -4 \Rightarrow \alpha = \dots$	M1	1.1b
	$\alpha = -2$	A1	1.1b
	So $\frac{1}{2} \times 2\beta \times 5 = 35 \Rightarrow \beta = 7$	M1	1.1b
	$q = -3(-2 + 7i)(-2 - 7i) = \dots$ or $p = 3(-2 + 7i) + 3(-2 - 7i) + (-2 + 7i)(-2 - 7i)$ or $(z - 3)(z - (-2 + 7i))(z - (-2 - 7i)) = \dots$	M1	3.1a
	$q = -159$ or $p = 41$	A1	1.1b
	$3p + q = -36 \Rightarrow p = \frac{-36 - q}{3} = 41$ and $q = -159$	A1	1.1b
		(7)	

	Alternative		
	$(z^3 + z^2 + pz + q) \div (z - 3) = z^2 + 4z + p + 12$	B1	3.1a
	$z^2 + 4z + p + 12 = 0 \Rightarrow z = \frac{-4 \pm \sqrt{4^2 - 4(p+12)}}{2} (= -2 \pm i\sqrt{p+8})$	M1	1.1b
	$\alpha = -2$	A1	1.1b
	$\beta = \sqrt{p+8}$	M1	1.1b
	$\frac{1}{2} \times (3+2) \times 2\sqrt{p+8} = 35 \Rightarrow p = \dots$	M1	3.1a
	$p = 41$	A1	1.1b
	$3p + q = -36 \Rightarrow q = -159$	A1	1.1b
		(7)	

(7 marks)

Notes
<p>B1: Recognises that the other roots must form a conjugate pair or obtains <math>z^2 + 4z + p + 12</math> (or <math>z^2 + 4z - \frac{q}{3}</math>) as the quadratic factor or writes down a correct equation for <math>p</math> and <math>q</math> or writes down a correct equation involving "<math>z_2</math>" and "<math>z_3</math>"</p> <p>M1: Uses the sum of the roots of the cubic or the sum of the roots of their quadratic to find a value for "<math>\alpha</math>"</p> <p>A1: Correct value for "<math>\alpha</math>"</p> <p>M1: Uses their value for "<math>\alpha</math>" and the given area to find a value for "<math>\beta</math>". Must be using the area and triangle dimensions correctly e.g. <math>\frac{1}{2} \times \beta \times 5 = 35 \Rightarrow \beta = 14</math> scores M0</p> <p>M1: Uses an appropriate method to find <math>p</math> or <math>q</math></p> <p>A1: A correct value for <math>p</math> or <math>q</math></p> <p>A1: Correct values for <math>p</math> and <math>q</math></p>
<b>Alternative</b>
<p>B1: Obtains <math>z^2 + 4z + p + 12</math> (or <math>z^2 + 4z - \frac{q}{3}</math>) as the quadratic factor</p> <p>M1: Solves their quadratic factor by completing the square or using the quadratic formula</p> <p>A1: Correct value for "<math>\alpha</math>"</p> <p>M1: Uses their imaginary part to find "<math>\beta</math>" in terms of <math>p</math></p> <p>M1: Draws together the fact that the imaginary parts of their complex conjugate pair and the real root form the sides of the required triangle and forms an equation in terms of <math>p</math>, sets equal to 35 and solves for <math>p</math></p> <p>A1: A correct value for <math>p</math> or <math>q</math></p> <p>A1: Correct values for <math>p</math> and <math>q</math></p>

## Q5.

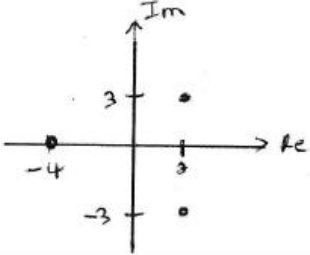
Question	Scheme	Marks	AOs
(a)	$2 + 3i$	B1	1.1b
		(1)	
(b) (i)	$z^* = 2 + 3i$ so $z + z^* = 4$ , $zz^* = 13$ $z + z^* + a = 0 \Rightarrow a = \dots$ or $azz^* = -52 \Rightarrow a = -\frac{52}{13} = \dots$ or $z^2 - (\text{sum roots})z + (\text{product roots}) = 0$ or $(z - (2 + 3i))(z - (2 - 3i)) = \dots$ $\Rightarrow (z^2 - 4z + 13)(z + 4) \Rightarrow z = \dots$	M1	3.1a
	$z = 2 \pm 3i, -4$	A1	1.1b
	(ii) $(z^2 - 4z + 13)(z + 4)$ expands the brackets to find value for $a$ Or $a = \text{pair sum} = -4(2 + 3i + 2 - 3i) + 13 = \dots$ Or $f(-4)/f(2 \pm 3i) = 0 \Rightarrow \dots \Rightarrow a = \dots$	M1	1.1b
	$a = -3$	A1	2.2a
		(4)	
(c)		B1ft	1.1b
		(1)	
(6 marks)			

## Notes:

(a)

B1:  $2 + 3i$ 

(b)

(i)

M1: A complete method to find the third root. E.g. forms the quadratic factor and uses this to find the linear factor leading to roots. Alternatively uses sum of roots = 0 or product of roots =  $\pm 52$  (condone sign error) with their complex roots to find the third. Note they may have used the factor theorem to find  $a$  first, which is fine. If they have found  $a$  first, then the correct third root seen implies this mark. The method may be implied by the third root seen on the diagram.

A1: Correct roots, all three must be clearly stated somewhere in (b), not just seen on a diagram in part (c).

(ii)

M1: Complete method to find a value for  $a$  e.g. multiplies out their quadratic and linear factors to find the coefficient of  $z$ , or uses pair sum, or uses factor theorem with one of the roots (may be done before finding the third root) but must reach a value for  $a$ .

A1: Deduces the correct value of  $a$ . May be seen as the  $z$  coefficient in the cubic (need not be extracted, but if it is it must be correct).

(c)

B1ft: Correctly plots all three roots following through their third root in part (b). Must be labelled with the “-4” further from  $O$  than 2, but don't be concerned about  $x$  and  $y$  scale. If correct look for one root on the negative real axis, with the other two symmetric about real axis in quadrants 1 and 4, but follow through their real root if positive. Accept  $(0, -4)$  labelled on the real axis in correct place as a label.

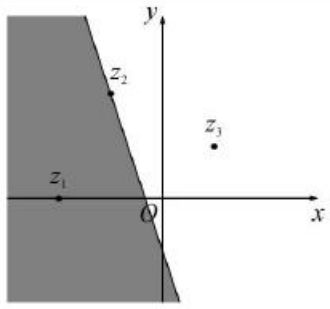

Q6.

Question	Scheme	Marks	AOs	
(a)	Complex roots of a real polynomial occur in conjugate pairs	M1	1.2	
	so a polynomial with $z_1, z_2$ and $z_3$ as roots also needs $z_2^*$ and $z_3^*$ as roots, so 5 roots in total, but a quartic has at most 4 roots, so no quartic can have $z_1, z_2$ and $z_3$ as roots.	A1	2.4	
		(2)		
(b)	$\frac{z_2 - z_1}{z_3 - z_1} = \frac{-1+2i-(-2)}{1+i-(-2)} = \frac{1+2i}{3+i} \times \frac{3-i}{3-i} = \dots$	M1	1.1b	
	$= \frac{3-i+6i+2}{9+1} = \frac{5+5i}{10} = \frac{1}{2} + \frac{1}{2}i$ oe	A1	1.1b	
	As $\frac{1}{2} + \frac{1}{2}i$ is in the first quadrant (may be shown by diagram), hence $\arg\left(\frac{z_2 - z_1}{z_3 - z_1}\right) = \arctan\left(\frac{1/2}{1/2}\right) (= \arctan(1)) = \frac{\pi}{4}^*$	A1*	2.1	
		(3)		
(c)	$\arg\left(\frac{z_2 - z_1}{z_3 - z_1}\right) = \arg(z_2 - z_1) - \arg(z_3 - z_1) = \arg(1+2i) - \arg(3+i)$	M1	1.1b	
	Hence $\arctan(2) - \arctan\left(\frac{1}{3}\right) = \frac{\pi}{4}^*$	A1*	2.1	
		(2)		
(d)		Line passing through $z_2$ and the negative imaginary axis drawn.	B1	1.1b
		Area below and left of their line shaded, where the line must have negative gradient passing through negative imaginary axis but need not pass through $z_2$	B1	1.1b
	Unless otherwise indicated by the student mark Diagram 1(if used) if there are multiple attempts.			
		(2)		
			(9 marks)	

<b>Notes</b>		
<b>(a)</b>	<b>M1</b>	Some evidence that complex roots occur as conjugate pairs shown, e.g. stated as in scheme, or e.g. identifying if $-1 + 2i$ is a root then so is $-1 - 2i$ . Mere mention of complex conjugates is sufficient for this mark.
	<b>A1</b>	A complete argument, referencing that a quartic has at most 4 roots, but would need at least 5 for all of $z_1, z_2$ and $z_3$ as roots. There should be a clear statement about the number of roots of a quartic (e.g. a quartic has four roots), and that this is not enough for the two conjugate pairs and real root.
<b>(b)</b>	<b>M1</b>	Substitutes the numbers in expression and attempts multiplication of numerator and denominator by the conjugate of their denominator or uses calculator to find the quotient. (May be implied.) NB Applying the difference of arguments and using decimals is M0 here.
	<b>A1</b>	Obtains $\frac{1}{2} + \frac{1}{2}i$ . (May be from calculator.) Accepted equivalent Cartesian forms.
	<b>A1*</b>	Uses arctan on their quotient and makes reference to first quadrant or draws diagram to show they are in the first quadrant. to justify the argument.
<b>(c)</b>	<b>M1</b>	Applies the formula for the argument of a difference of complex numbers and substitutes values (may go directly to arctans if the arguments have already been established). If used in (b) it must be seen or referred to in (c) for this mark to be awarded. Allow for $\arg(z_2 - z_1) - \arg(z_3 - z_1)$ if $z_2 - z_1$ and $z_3 - z_1$ have been clearly identified in earlier work.
	<b>A1*</b>	Completes the proof clearly by identifying the required arguments and using the result of (b). Use of decimal approximations is A0.
<b>(d)</b>	<b>B1</b>	Draws a line through $z_2$ and passing through negative imaginary axis.
	<b>B1</b>	Correct side of bisector shaded. Allow this mark if the line does not pass through $z_2$ . But it should be an attempt at the perpendicular bisector of the other two points – so have negative gradient and pass through the negative real axis.
Ignore any other lines drawn for these two marks.		

Q7.

Question	Scheme	Marks	AOs	
(a)	$ w  = \sqrt{(4\sqrt{3})^2 + (-4)^2} = 8$	B1	1.1b	
	$\arg w = \arctan\left(\frac{-4}{4\sqrt{3}}\right) = \arctan\left(\pm \frac{1}{\sqrt{3}}\right)$	M1	1.1b	
	$= -\frac{\pi}{6}$	A1	1.1b	
	So $(w =) 8\left(\cos\left(-\frac{\pi}{6}\right) + i \sin\left(-\frac{\pi}{6}\right)\right)$	A1	1.1b	
		(4)		
(b)	<p><math>\arg(z + 10i) = \frac{\pi}{3}</math></p>	(i) $w$ in 4 <sup>th</sup> quadrant with either $(4\sqrt{3}, -4)$ seen or $-\frac{\pi}{4} < \arg w < 0$	B1	1.1b
		(ii) half line with positive gradient emanating from imaginary axis.	M1	1.1b
		The half line should pass between $O$ and $w$ starting from a point on the imaginary axis below $w$	A1	1.1b
		(3)		
(c)		$\Delta OAX$ is right angled at $X$ so $OX = 10 \sin \frac{\pi}{6} = 5$ (oe)	M1	3.1a
		So shortest distance is $WX = OW - OX = '8' - 5 = \dots$	M1	1.1b
		So min distance is 3	A1	1.1b
Alternative 1		A complete method to find the coordinates of $X$ . Finds the equation of the line from $O$ to $w$ , $y = -\frac{1}{\sqrt{3}}x$ and the equation of the half line $y = \sqrt{3}x - 10$ , solves to find the point of intersection $X\left(\frac{5\sqrt{3}}{2}, -\frac{5}{2}\right)$	M1	3.1a
		Finds the length $WX$ $\sqrt{\left(4\sqrt{3} - \frac{5\sqrt{3}}{2}\right)^2 + \left(-4 - -\frac{5}{2}\right)^2}$	M1	1.1b
		So min distance is 3	A1	1.1b
Alternative 2		M1	3.1a	

	<p>Finds the length <math>AW = \sqrt{(4\sqrt{3}-0)^2 + (-4--10)^2} = \dots\{\sqrt{84}\}</math></p> <p>Finds the angle between the horizontal and the line <math>AW</math></p> <p><math>= \tan^{-1}\left(\frac{-4--10}{4\sqrt{3}}\right) = \dots\{0.7137\dots\text{radians or } 40.89\dots^\circ\}</math></p>		
	<p>Finds the length of <math>WX = \sqrt{84} \times \sin\left(\frac{\pi}{3} - 0.7137\right) = \dots</math></p> <p>Or <math>= \sqrt{84} \times \sin(60 - 40.89) = \dots</math></p>	M1	1.1b
	So min distance is 3	A1	1.1b

	<p><b>Alternative 3</b></p> <p>Vector equation of the half line <math>r = \begin{pmatrix} 0 \\ -10 \end{pmatrix} + \lambda \begin{pmatrix} 1 \\ \sqrt{3} \end{pmatrix}</math></p> <p><math>XW = \begin{pmatrix} 4\sqrt{3} - \lambda \\ -4 - \lambda\sqrt{3} - (-10) \end{pmatrix}</math></p> <p>Then either</p> <p><math>\begin{pmatrix} 4\sqrt{3} - \lambda \\ 6 - \lambda\sqrt{3} \end{pmatrix} \cdot \begin{pmatrix} 1 \\ \sqrt{3} \end{pmatrix} = 4\sqrt{3} - \lambda + 6\sqrt{3} - 3\lambda = 0 \Rightarrow \lambda = \dots\left\{\frac{5}{2}\sqrt{3}\right\}</math></p> <p><math>r = \begin{pmatrix} 0 \\ -10 \end{pmatrix} + \frac{5}{2}\sqrt{3} \begin{pmatrix} 1 \\ \sqrt{3} \end{pmatrix} = \dots</math></p> <p>Or <math>XW^2 = (4\sqrt{3} - \lambda)^2 + (6 - \lambda\sqrt{3})^2 = 48 - 8\lambda\sqrt{3} + \lambda^2 + 36 - 12\lambda\sqrt{3} + 3\lambda^2</math></p> <p><math>xw^2 = 84 - 20\lambda\sqrt{3} + 4\lambda^2</math> leading to</p> <p><math>\frac{d(XW^2)}{d\lambda} = -20\sqrt{3} + 8\lambda = 0 \Rightarrow \lambda = \dots</math></p>	M1	3.1a
	<p>Finds the length <math>WX = \sqrt{\left(4\sqrt{3} - \frac{5\sqrt{3}}{2}\right)^2 + \left(-4 - \frac{5}{2}\right)^2}</math></p> <p>Or <math>XW = \sqrt{\left(4\sqrt{3} - \frac{5}{2}\sqrt{3}\right)^2 + \left(6 - \frac{5}{2}\sqrt{3}\sqrt{3}\right)^2}</math></p>	M1	1.1b
	So min distance is 3	A1	1.1b
		(3)	

(10 marks)

**Notes:**

(a)

**B1:** Correct modulus

**M1:** Attempts the argument. Allow for  $\arctan\left(\frac{\pm 4}{\pm 4\sqrt{3}}\right)$  or equivalents using the modulus (may be in wrong quadrant for this mark).

**A1:** Correct argument  $-\frac{\pi}{6}$  (must be in fourth quadrant but accept  $\frac{11\pi}{6}$  or other difference of  $2\pi$  for this mark).



**A1:** Correct expression found for  $w$ , in the correct form, must have positive  $r=8$  and  $\theta = -\frac{\pi}{6}$ .

**Note:** using degrees B1 M1 A0 A0

**(b)(i)&(ii)**

**B1:**  $w$  plotted in correct quadrant with either the correct coordinate clearly seen or above the line  $y = -x$

**M1:** Half line drawn starting on the imaginary axis away from  $O$  with positive gradient (need not be labelled)

**A1:** Sketch on **one diagram**— both previous marks must have been scored and the half line should pass between  $O$  and  $w$  starting from a point on the imaginary axis below  $w$ . (You may assume it starts at  $-10i$  unless otherwise stated by the candidate)

**Note:** If candidates draw the loci on separate diagrams the maximum they can score is B1 M1 A0

**(c)**

**M1:** Formulates a correct strategy to find the shortest distance, e.g. uses right angle  $OXA$  where  $X$  is where the lines meet and proceeds at least as far as  $OX$ .

**M1:** Full method to achieve the shortest distance, e.g. for  $WX = OW - OX$ .

**A1:** cao shortest distance is 3

**Alternative 1:**

**M1:** Uses a correct method to find the equation of the line from  $O$  to  $w$ ,  $y = -\frac{1}{\sqrt{3}}x$  and the equation of the half line  $y = \sqrt{3}x - 10$ , solves to find the point of intersection  $X\left(\frac{5\sqrt{3}}{2}, -\frac{5}{2}\right)$

If the incorrect gradient(s) is used with no valid method seen this is M0

**M1:** Finds the length  $WX = \sqrt{\left(\text{their } \frac{5\sqrt{3}}{2} - 4\sqrt{3}\right)^2 + \left(\text{their } -\frac{5}{2} - -4\right)^2} = \dots$  condone a sign slip in the brackets.

**A1:** cao shortest distance is 3

**Alternative 2:**

**M1:** Uses a correct method to find the length  $AW$  and a correct method to find the angle between the horizontal and the line  $AW$

**M1:** Finds the length of  $WX = \text{their } \sqrt{84} \times \sin\left(\frac{\pi}{3} - \text{their } 0.7137\right) = \dots$

**A1:** cao shortest distance is 3

**Alternative 3**

**M1:** Finds the vector equation of the half line, then  $XW$ .

**Then either:** Sets dot product  $XW$  and the line  $= 0$  and solves for  $\lambda$ . Substitutes their  $\lambda$  into the equation of the half line to find the point of intersection.

**Or** finds the length of  $XW$  and differentiates, set  $= 0$  and solve for  $\lambda$

**M1:** Finds the length  $WX = \sqrt{\left(\text{their } \frac{5\sqrt{3}}{2} - 4\sqrt{3}\right)^2 + \left(\text{their } -\frac{5}{2} - -4\right)^2} = \dots$  condone a sign slip in the brackets.

**Or** substitutes their value for  $\lambda$  into the length of  $(d)$

**A1:** cao shortest distance is 3

**Q8.**

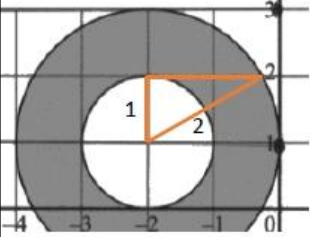
Question	Scheme	Marks	AOs
(a)	$a = 1, d = 2$	B1	1.1b
	$b = 2$	B1	1.1b
	$c = -1$	B1	1.1b
	(3)		
(b)	$ z - i  =  z - 3i  \Rightarrow y = 2$	B1	2.2a
	Area between the circles = $\pi \times 2^2 - \pi \times 1^2$	M1	1.1a
	 <p>Angle subtended at centre = <math>2 \times \cos^{-1}\left(\frac{1}{2}\right)</math>                      Alternatively  <math>(x+2)^2 + (y-1)^2 = 4, y = 2 \Rightarrow x = \dots</math>                      Or <math>x = \sqrt{2^2 - 1^2}</math>                      Leading to Angle subtended at centre = <math>2 \times \tan^{-1}\left(\frac{\sqrt{3}}{1}\right)</math></p>	M1	3.1a
	Segment area = $\frac{1}{2} \times \frac{2\pi}{3} \times 2^2 - \frac{1}{2} \times 2^2 \times \sin\left(\frac{2\pi}{3}\right) \left\{ = \frac{4}{3}\pi - \sqrt{3} \right\}$	M1 A1	2.1 1.1b
	Area of Q: $\pi \times 2^2 - \pi \times 1^2 - \left( \frac{1}{2} \times \frac{2\pi}{3} \times 2^2 - \frac{1}{2} \times 2^2 \times \sin\left(\frac{2\pi}{3}\right) \right)$	M1	3.1a
	$= \frac{5\pi}{3} + \sqrt{3}$	A1	1.1b
	(7)		

(10 marks)

Notes
(a) B1: Correct values for $a$ and $d$ B1: Correct value for $b$ B1: Correct value for $c$ (b) B1: Deduces that $ z - i  =  z - 3i $ is a perpendicular bisector with equation $y = 2$ , this may be drawn on a diagram. M1: Selects the correct procedure to find the area of the large circle – the area of the small circle. M1: Correct method to find the angle at the centre (or half this angle). Recognises that the hypotenuse is the radius of the larger circle and the adjacent is the radius of the smaller circle and using cosine Alternatively find where the perpendicular bisector intersects the larger circle so uses their $y = 2$ and the equation of the larger circle in an attempt to establish the $x$ values for the intersection points or uses geometry and Pythagoras to identify the required length and then uses tangent. M1: Correct method for the area of the minor segment (allow equivalent work) A1: Correct expression M1: Fully correct strategy for the required area. Must be subtracting the area of the minor segment from the annulus area. A1: Correct exact answer Note: 6.968

**Q9.**

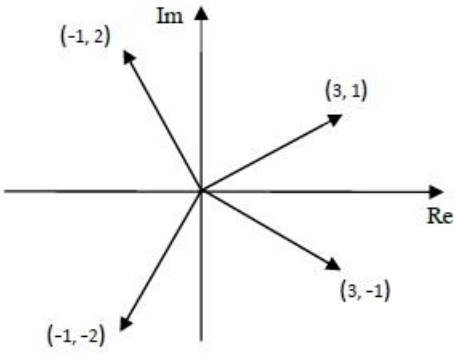
Question	Scheme	Marks	AOs	
(a)	$z = -1 - 2i$ or $z = 3 + i$	M1	1.2	
	$z = -1 - 2i$ and $z = 3 + i$	A1	1.1b	
		B1	1.1b	
		B1	1.1b	
	(4)			
(b) Way 1	$(z - (-1 + 2i))(z - (-1 - 2i)) = \dots$ or $(z - (3 + i))(z - (3 - i)) = \dots$	$f(z) = (z - (-1 + 2i))(z - (-1 - 2i))$ $(z - (3 + i))(z - (3 - i)) = \dots$	M1	3.1a
	$z^2 + 2z + 5$ or $z^2 - 6z + 10$	e.g. $f(z) = (z^2 + 2z + 5)(\dots)$	A1	1.1b
	$z^2 + 2z + 5$ and $z^2 - 6z + 10$	$f(z) = (z^3 + z^2(-1 - i) + z(-1 + 2i) - 15 - 5i)(\dots)$	A1	1.1b
	$f(z) = (z^2 + 2z + 5)(z^2 - 6z + 10)$	Expands the brackets to form a quartic	M1	3.1a
	$f(z) = z^4 - 4z^3 + 3z^2 - 10z + 50$ or States $a = -4, b = 3, c = -10, d = 50$		A1	1.1b
	(5)			

Question	Scheme	Marks	AOs
Way 2	sumroots = $\alpha + \beta + \gamma + \delta = (-1+2i) + (-1-2i) + (3+i) + (3-i) = \dots$	M1	3.1a
	pair sum = $\alpha\beta + \alpha\gamma + \alpha\delta + \beta\gamma + \beta\delta + \gamma\delta$ $= (-1+2i)(-1-2i) + (-1+2i)(3-i) + (-1+2i)(3+i) + (-1-2i)(3-i)$ $+ (-1-2i)(3+i) + (3+i)(3-i) = \dots$		
	triple sum = $\alpha\beta\gamma + \alpha\beta\delta + \beta\gamma\delta + \alpha\gamma\delta$ $= (-1+2i)(-1-2i)(3-i) + (-1+2i)(-1-2i)(3+i) + (-1+2i)(3+i)(3-i)$ $+ (-1-2i)(3+i)(3-i) = \dots$		
	Product = $\alpha\beta\gamma\delta = (-1+2i)(-1-2i)(3-i)(3+i) = \dots$		
	sum = 4, pair sum = 3, triple sum = 10 and product = 50	A1 A1	1.1b 1.1b
	$a = -(\text{their sum roots}) = -4$ $b = +(\text{their pair sum}) = 3$ $c = -(\text{triple sum}) = -10$ $d = +(\text{product}) = 50$	M1 A1	3.1a 1.1b
		(5)	
Way 3	$f z = -1+2i^4 + a -1+2i^3 + b -1+2i^2 + c -1+2i + d = 0$ $f z = 3+i^4 + a 3+i^3 + b 3+i^2 + c 3+i + d = 0$ Leading to $-7+11a-3b-c+d=0$ $24-2a-4b+2c=0$ $28+18a+8b+3c+d=0$ $96+26a+6b+c=0$	M1	3.1a
	Solves their simultaneous equation to find a value for one of the constants	M1	3.1a
	$a = -4, b = 3, c = -10, d = 50$	A1	1.1b
		(5)	

(9 marks)



## Notes

(a)

M1: Identifies at least one correct complex conjugate as another root (can be seen/implied by Argand diagram)

A1: Both complex conjugate roots identified correctly (can be seen/implied by Argand diagram)

For the next two marks allow either a cross, dot or line drawn where the end point is labelled with the correct coordinate, corresponding complex number or clearly plotted with correct numbers labelled on the axis or indication of the correct coordinates by use of scale markers. Condone (3, i) etc. The axes do not need to be labelled with Re and Im.

B1: One complex conjugate pair correctly plotted.

B1: Both complex conjugate pair correctly plotted. The  $3 \pm i$  must be closer to the real axes than the  $-1 \pm 2i$

If there is no indication of the coordinates, scale or complex numbers on the Argand diagram this is B0 B0.

Do accept correct labelling e.g.

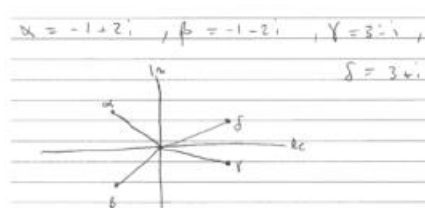

(b)

Way 1

M1: Correct strategy for forming at least one of the quadratic factors. Follow through their roots.

A1: At least one correct simplified quadratic factor.

A1: Both simplified quadratic factors correct or a correct simplified cubic factor

M1: A complete strategy to find values for  $a$ ,  $b$ ,  $c$  and  $d$  e.g. uses their quadratic factors or cubic and linear factor to form a quartic.

A1: Correct quartic in terms of  $z$  or correct values for  $a$ ,  $b$ ,  $c$  and  $d$  stated.

Way 2

M1: Correct strategy for finding at least three of the sum roots, pair sum, triple sum and product. Follow through their roots. This can be implied by at least three correct values for the sum roots, pair sum, triple sum and product with no working shown. If the calculations are not shown for the sums and product and they have at least two incorrect values this is M0.

A1: At least two correct values for the sum roots, pair sum, triple sum or product.

A1: All correct values for the sum, pair sum, triple sum and product.

M1: Must have real values of  $a$ ,  $b$ ,  $c$  and  $d$  and use  $a = -$ their sum roots,  $b =$  their pair sum,  $c = -$ their triple sum and  $d =$  their product.

A1: Correct quartic in terms of  $z$  or correct values for  $a$ ,  $b$ ,  $c$  and  $d$  stated.

Way 3

M1: Substitutes two roots into  $f(z) = 0$  and equates coefficients to form 4 equations

A1: At least two correct equations.

A1: All four correct equations

M1: Solve their four equation (using calculator) to find at least one value. This will need checking if incorrect equations used.

A1: Correct quartic in terms of  $z$  or correct values for  $a$ ,  $b$ ,  $c$  and  $d$  stated.

**Note:** Correct answer only will score 5/5

## Q10.

Question	Scheme	Marks	AOs
	$z_2 = 2 - 3i$	B1	1.1b
	$(z_3 = )p - 3i$ and $(z_4 = )p + 3i$ May be seen in an Argand diagram	M1	3.1a
	$(z_3 = )-4 - 3i$ and $(z_4 = )-4 + 3i$ May be seen in an Argand diagram, but the complex numbers used in their method takes precedence	A1	1.1b
	$(z^2 - 4z + 13)(z^2 + 8z + 25)$ <p style="text-align: center;">or</p> $(z - (2 - 3i))(z - (2 + 3i))(z - (-4 - 3i))(z - (-4 + 3i))$ <p style="text-align: center;">or</p> $a = -[(2 - 3i) + (2 + 3i) + (-4 - 3i) + (-4 + 3i)]$ <p style="text-align: center;">and</p> $b = (2 - 3i)(2 + 3i) + (2 - 3i)(-4 - 3i) + (2 - 3i)(-4 + 3i) + (2 + 3i)(-4 - 3i) + (2 + 3i)(-4 + 3i) + (-4 - 3i)(-4 + 3i)$ <p style="text-align: center;">and</p> $c = -\left[ \begin{array}{l} (2 - 3i)(2 + 3i)(-4 - 3i) + (2 - 3i)(2 + 3i)(-4 + 3i) \\ + (2 - 3i)(-4 - 3i)(-4 + 3i) + (2 + 3i)(-4 - 3i)(-4 + 3i) \end{array} \right]$ <p style="text-align: center;">and</p> $d = (2 - 3i)(2 + 3i)(-4 - 3i)(-4 + 3i)$ <p style="text-align: center;">or</p> <p>Substitutes in one root from each conjugate pair and equates real and imaginary parts and solves simultaneously</p> $(2 \pm 3i)^4 + a(2 \pm 3i)^3 + b(2 \pm 3i)^2 + c(2 \pm 3i) + d = 0$ $(-4 \pm 3i)^4 + a(-4 \pm 3i)^3 + b(-4 \pm 3i)^2 + c(-4 \pm 3i) + d = 0$	dM1	3.1a
	$a = 4, b = 6, c = 4, d = 325$	A1	1.1b
	$f(z) = z^4 + 4z^3 + 6z^2 + 4z + 325$	A1	1.1b
		(6)	
<b>(6 marks)</b>			

## Notes:

B1: Seen  $2 - 3i$ M1: Finds the third and fourth roots of the form  $p \pm 3i$ . May be seen in an Argand diagramA1: Third and fourth roots are  $-4 \pm 3i$ . May be seen in an Argand diagramdM1: Uses an appropriate method to find  $f(z)$ . If using roots of a polynomial at least 3 coefficients must be attempted.A1: At least two of  $a, b, c, d$  correctA1: All  $a, b, c$  and  $d$  correctNote: Using roots  $2 \pm 3i$  and  $-2 \pm 3i$  leads to  $z^4 + 10z^2 + 169$  Maximum score B1 M1 A0 M1 A0 A0

Q11.

Question	Scheme	Marks	AOs
(a)	$ z_1  = \sqrt{13}$ and $\arg z_1 = \tan^{-1}\left(\frac{3}{2}\right)$	B1	1.1b
	$z_1 = \sqrt{13}(\cos 0.9828 + i \sin 0.9828)$	B1ft	1.1b
		(2)	

(b)	A complete method to find the modulus of $z_2$ e.g. $ z_1  = \sqrt{13}$ and uses $ z_1 z_2  =  z_1  \times  z_2  = 39\sqrt{2} \Rightarrow  z_2  = 3\sqrt{26}$ or $\sqrt{234}$	M1 A1	3.1a 1.1b
	A complete method to find the argument of $z_2$ e.g. $\arg(z_1 z_2) = \arg(z_1) + \arg(z_2) = \frac{\pi}{4} \Rightarrow \arg(z_2) = \dots$ $\arg(z_2) = \frac{\pi}{4} - \tan^{-1}\left(\frac{3}{2}\right)$ or $\frac{\pi}{4} - 0.9828$ or $-0.1974\dots$	M1 A1	3.1a 1.1b
	$z_2 = 3\sqrt{26}(\cos(' - 0.1974\dots ')) + i \sin(' - 0.1974\dots '))$ or $z_2 = a + bi \Rightarrow a^2 + b^2 = 234$ and $\tan^{-1}(-0.1974) = \frac{b}{a} \Rightarrow \frac{b}{a} = -0.2$ $\Rightarrow a = \dots$ and $b = \dots$	ddM1	1.1b
	Deduces that $z_2 = 15 - 3i$ only	A1	2.2a
	<b>Alternative</b> $z_1 z_2 = (a + bi)(2 + 3i) = (2a - 3b) + (3a + 2b)i$		
	$(2a - 3b)^2 + (3a + 2b)^2 = (39\sqrt{2})^2$ or 3042 $\Rightarrow a^2 + b^2 = 234$ or $ z_1 z_2  =  z_1  \times  z_2  = 39\sqrt{2} \Rightarrow  z_2  = 3\sqrt{26}$ or $\sqrt{234}$ $\Rightarrow a^2 + b^2 = 234$	M1 A1	3.1a 1.1b
	$\arg[(2a - 3b) + (3a + 2b)i] = \frac{\pi}{4} \Rightarrow \tan^{-1}\left(\frac{3a + 2b}{2a - 3b}\right) = \frac{\pi}{4} \Rightarrow \frac{3a + 2b}{2a - 3b} = 1$ $\Rightarrow a = -5b$	M1 A1	3.1a 1.1b
	Solves $a = -5b$ and $a^2 + b^2 = 234$ to find values for $a$ and $b$	ddM1	1.1b
	Deduces that $z_2 = 15 - 3i$ only	A1	2.2a
		(6)	

(8 marks)



**Notes:****(a)**

**B1:** Correct exact value for  $|z_1| = \sqrt{13}$  and  $\arg z_1 = \tan^{-1}\left(\frac{3}{2}\right)$ . The value for  $\arg z_1$  can be implied by sight of awrt 0.98 or awrt  $56.3^\circ$

**B1ft:** Follow through on  $r = |z_1|$  and  $\theta = \arg z_1$  and writes  $z_1 = r(\cos \theta + i \sin \theta)$  where  $r$  is exact and  $\theta$  is correct to 4 s.f. do not follow through on rounding errors.

**(b)**

**M1:** A complete method to find the modulus of  $z_2$

**A1:**  $|z_2| = 3\sqrt{26}$

**M1:** A complete method to find the argument of  $z_2$

**A1:**  $\arg(z_2) = \frac{\pi}{4} - \tan^{-1}\left(\frac{3}{2}\right)$  or  $\frac{\pi}{4} - 0.9828$  or  $-0.1974\dots$

**ddM1:** Writes  $z_2$  in the form  $r(\cos \theta + i \sin \theta)$ , dependent on both previous M marks.

Alternative forms two equations involving  $a$  and  $b$  using the modulus and argument of  $z_2$  and solve to find values for  $a$  and  $b$

**A1:** Deduces that  $z_2 = 15 - 3i$  only

**(b) Alternative:**  $z_1 z_2 = (a + bi)(2 + 3i) = (2a - 3b) + (3a + 2b)i$

**M1:** A complete method to find an equation involving  $a$  and  $b$  using the modulus

**A1:** Correct simplified equation  $a^2 + b^2 = 234$  o.e.

**M1:** A complete method to find an equation involving  $a$  and  $b$  using the argument.

Note  $\tan^{-1}\left(\frac{2a - 3b}{3a + 2b}\right) = \frac{\pi}{4}$  this would score **M0 A0 ddM0 A0**

**A1:** Correct simplified equation  $a = -5b$  o.e.

**ddM1:** Dependent on both the previous method marks. Solves their equations to find values for  $a$  and  $b$

**A1:** Deduces that  $z_2 = 15 - 3i$  only