

Questions

Q1.

This question concerns halogenoalkanes.

1-chloropropane can react to form organic products as shown in the reaction scheme:

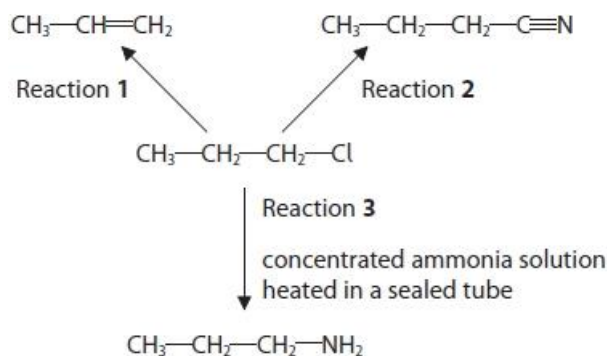

(i) State the reagent and conditions used in Reaction 1.

(2)

.....

(ii) Identify a suitable reagent for Reaction 2 and include a reason why this is a particularly useful type of reaction in organic chemistry.

(2)

Reagent

.....

Reason

.....

(iii) Explain why, in Reaction 3, the reactants are **heated** in a **sealed** container.

(2)

.....

(iv) Write the structural formula of the product that will be formed if 1-chloropropane is refluxed with **aqueous** potassium hydroxide solution.

(1)

(Total for question = 7 marks)

Edexcel Chemistry A-level - Halogenoalkanes

Q2.

This question is about halogenoalkanes.

The tables show some relevant data.

| Bond | Bond enthalpy / kJ mol ⁻¹ | Atom | Electronegativity |
|------|--------------------------------------|------|-------------------|
| C—F | 467 | C | 2.5 |
| C—Cl | 346 | F | 4.0 |
| C—Br | 290 | Cl | 3.0 |
| C—I | 228 | Br | 2.8 |
| | | I | 2.5 |

(a) In an experiment, 1 cm³ of ethanol and 5 cm³ of 0.1 mol dm⁻³ silver nitrate were placed in each of three test tubes X, Y and Z. The test tubes and their contents were placed in a water bath at 50°C for five minutes.

Two drops of 1-chlorobutane were then added to test tube X and the tube was shaken to mix the contents. The time taken for a precipitate to appear was measured.

The experiment was repeated using two drops of 1-bromobutane in test tube Y and two drops of 1-iodobutane in test tube Z.

(i) The time taken for a precipitate to appear increases in the order

(1)

- A X, Y, Z
- B Z, Y, X
- C Y, X, Z
- D Z, X, Y

(ii) Give a reason for the addition of ethanol to each test tube.

(1)

.....
.....

(iii) Give a reason why the test tubes were left in the water bath for five minutes before adding the halogenoalkanes.

(1)

.....
.....
.....

Edexcel Chemistry A-level - Halogenoalkanes

(iv) The precipitates form as a result of reactions between aqueous silver ions and aqueous halide ions.

Explain why halide ions are present in the mixture containing a halogenoalkane which has only covalent bonds.

(2)

.....

.....

.....

.....

.....

.....

(v) Write the ionic equation, including state symbols, for the reaction involving the silver nitrate in test tube X.

(1)

(b) 1-bromo-2-methylpropane was mixed with a large excess of potassium hydroxide solution.

The 1-bromo-2-methylpropane is hydrolysed during the reaction and its concentration decreases as the reaction proceeds. Samples of the reaction mixture were analysed at time intervals to determine the remaining concentration of 1-bromo-2-methylpropane.

| Time/s | [1-bromo-2-methylpropane]/mol dm ⁻³ |
|--------|------------------------------------------------|
| 0 | 0.1000 |
| 50 | 0.0500 |
| 100 | 0.0250 |
| 200 | 0.0063 |
| 300 | 0.0016 |

Edexcel Chemistry A-level - Halogenoalkanes

(i) Draw a graph of [1-bromo-2-methylpropane] against time.

(3)

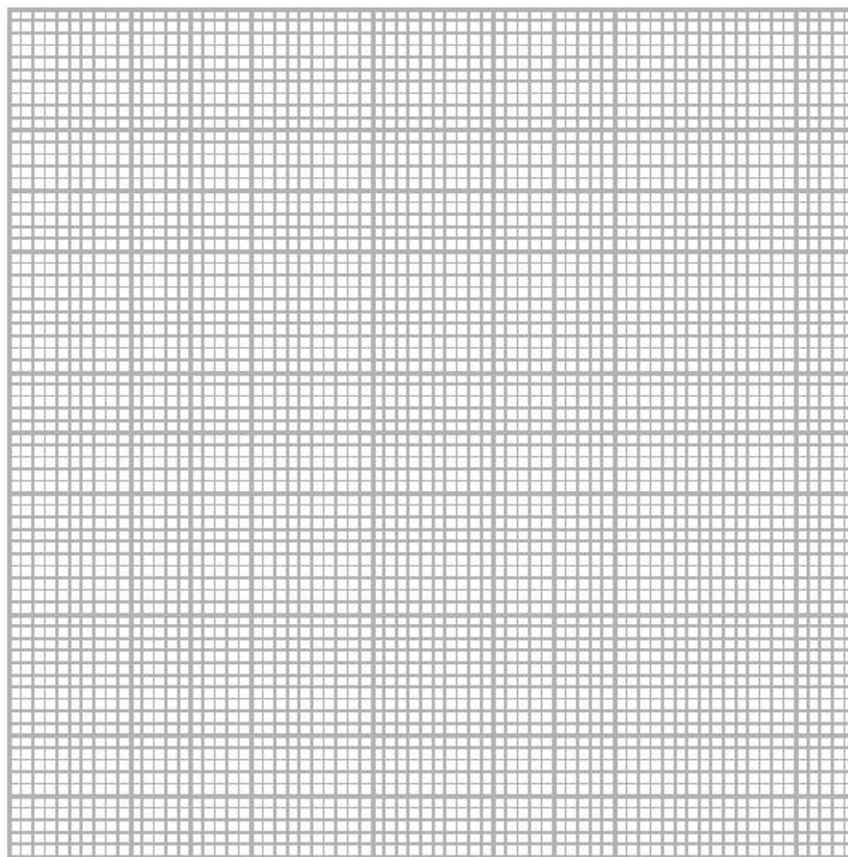

(ii) Use your graph to calculate a value for the rate of reaction at 100 s. Include units in your answer.

(3)

(c) (i) Which term best describes the role of the OH^- ion in the reaction in (b)?

(1)

- A catalyst
- B electrophile
- C free radical
- D nucleophile

Edexcel Chemistry A-level - Halogenoalkanes

(ii) Draw a diagram to show the mechanism for the hydrolysis of 1-bromo-2-methylpropane by the hydroxide ion. Include any appropriate lone pairs and dipoles.

(4)

(iii) The hydrolysis reaction described in part (b) may also be classified as

(1)

- A addition
- B elimination
- C redox
- D substitution

(Total for question = 18 marks)

Edexcel Chemistry A-level - Halogenoalkanes

Q3.

This is a question about the hydrolysis of halogenoalkanes.

Devise an experiment, giving outline details only, that would enable the relative rates of hydrolysis of halogenoalkanes to be compared.

(5)

.....

.....

.....

.....

.....

.....

.....

.....

.....

.....

.....

.....

.....

.....

.....

.....

.....

.....

.....

.....

.....

.....

(Total for question = 5 marks)

Edexcel Chemistry A-level - Halogenoalkanes

Q4.

This question is about halogenoalkanes and kinetics.

Some halogenoalkanes are hydrolysed by aqueous potassium hydroxide.

(i) Write the **ionic** equation for the hydrolysis of 2-bromobutane showing the **structural** formulae for the organic molecules.

(1)

*(ii) Devise an experiment to compare the rates of hydrolysis of 2-chlorobutane, 2-bromobutane and 2-iodobutane.

State the trend in the rates of reaction. Justify your answer.

(6)

.....

.....

.....

.....

.....

.....

.....

.....

.....

.....

.....

.....

.....

.....

.....

.....

.....

.....

.....

.....

(Total for question = 7 marks)

Edexcel Chemistry A-level - Halogenoalkanes

Q5.

A series of experiments was carried out to determine the kinetics of the reaction between a chloroalkane, RCl, and potassium hydroxide in aqueous solution. A large excess of the chloroalkane was used.

The data obtained are shown.

| $[\text{OH}^-] / \text{mol dm}^{-3}$ | Time / s |
|--------------------------------------|----------|
| 0.00100 | 39 |
| 0.00200 | 31 |
| 0.00300 | 23 |
| 0.00400 | 16 |
| 0.00500 | 8 |

(a) Plot a graph of the concentration of the hydroxide ions against time.

(2)

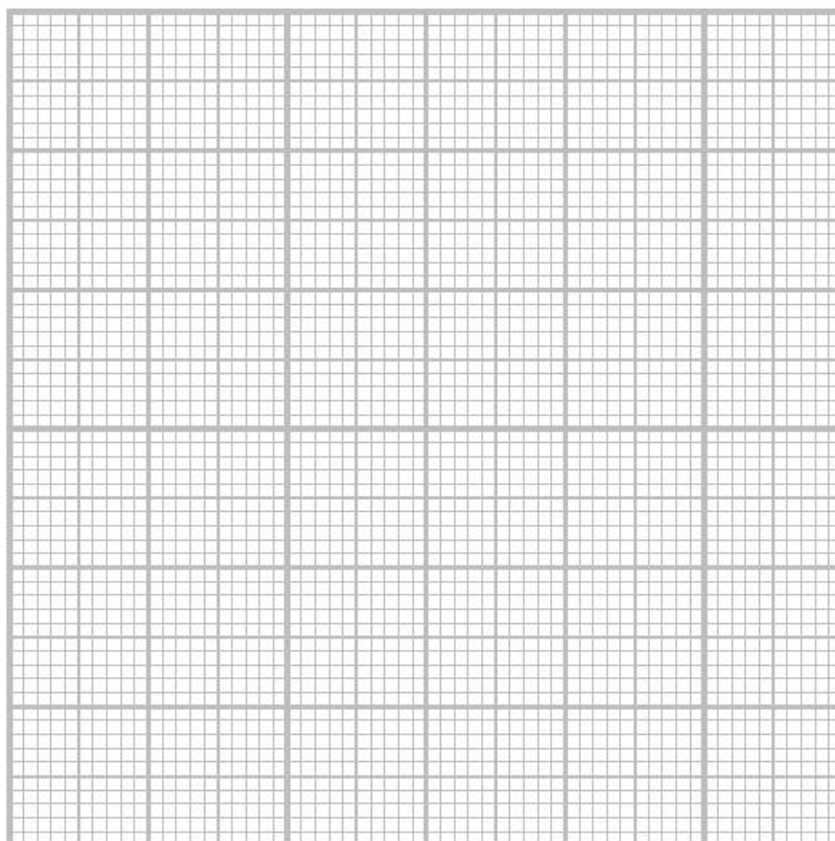

Edexcel Chemistry A-level - Halogenoalkanes

- (b) State the order with respect to hydroxide ions.
Justify your answer by reference to your graph in (a).

(2)

.....

.....

.....

.....

- (c) Deduce the type of mechanism occurring.
Justify your answer.

(2)

.....

.....

.....

.....

.....

.....

- (d) Give the classification of the chloroalkane in this reaction.

(1)

.....

.....

(Total for question = 7 marks)

Edexcel Chemistry A-level - Halogenoalkanes

Q6.

The chemistry of organic compounds containing a chlorine atom is affected by the presence of other groups.

Consider the reaction of ammonia, NH_3 , with $\text{CH}_3\text{CH}_2\text{CH}_2\text{Cl}$ and with $\text{CH}_3\text{CH}_2\text{COCl}$.

Draw the mechanism for the reaction of $\text{CH}_3\text{CH}_2\text{CH}_2\text{Cl}$ with an **excess** of ammonia to form the primary amine. Include curly arrows and relevant lone pairs.

(3)

(Total for question = 3 marks)

Edexcel Chemistry A-level - Halogenoalkanes

Q7.

This is a question about halogenoalkanes and related compounds.

The halogenoalkane 2-bromobutane reacts with ethanolic potassium hydroxide to produce a mixture of alkenes.

Draw the **skeletal** formulae of all the alkenes that could be produced.

(3)

(Total for question = 3 marks)

Edexcel Chemistry A-level - Halogenoalkanes

Q8.

This question is about esters with the molecular formula $C_6H_{12}O_2$.

Propyl propanoate has the structure shown.

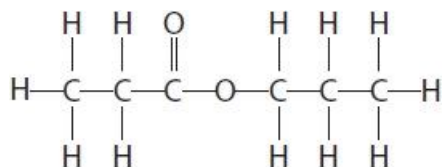

Devise a synthetic pathway to prepare propyl propanoate starting with 1-bromopropane as the **only** organic compound.

Include the reagents for each step in the synthesis, and the names or structures of the intermediate compounds.

(5)

(Total for question = 5 marks)

Edexcel Chemistry A-level - Halogenoalkanes

Q9.

Answer the question with a cross in the box you think is correct . If you change your mind about an answer, put a line through the box and then mark your new answer with a cross .

Bromobutanes react with hot ethanolic potassium hydroxide solution to produce gaseous butenes.

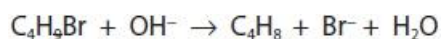

Apparatus

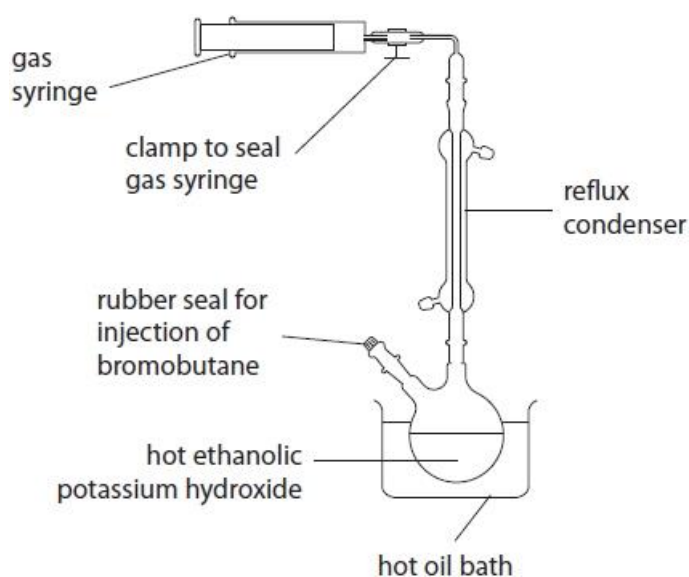

Procedure

- 0.0080 mol of liquid 1-bromobutane was injected into a round bottom flask containing hot ethanolic potassium hydroxide.
- After the reaction, the syringe was sealed using a clamp.
- The syringe was then removed from the apparatus and allowed to cool to room temperature (298 K).

Result

The final volume of but-1-ene collected was 22.0 cm³.

Alkene molecules are formed by elimination from 2-bromobutane.

How many isomeric alkene products will be formed in this reaction?

- A 1
 B 2
 C 3
 D 4

(1)

(Total for question = 1 mark)

Edexcel Chemistry A-level - Halogenoalkanes

Q11.

A bromoalkane, RBr, reacts with aqueous hydroxide ions in a nucleophilic substitution reaction.

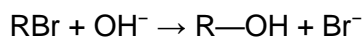

This reaction is first order with respect to the bromoalkane and the rate equation is

$$\text{rate} = k[\text{RBr}]^1[\text{OH}^-]^x$$

where x is the order of the reaction with respect to hydroxide ions.

In an experiment, a sample of the bromoalkane was added to a large excess of aqueous sodium hydroxide and the concentration of the bromoalkane was determined at regular time intervals.

Results

| Time / s | [RBr] / mol dm ⁻³ |
|----------|------------------------------|
| 0 | 0.100 |
| 30 | 0.065 |
| 60 | 0.042 |
| 90 | 0.028 |
| 120 | 0.019 |
| 150 | 0.014 |

This experiment is carried out using the bromoalkane dissolved in ethanol and the hydroxide ions dissolved in water.

Give a reason why a solution of hydroxide ions dissolved in pure ethanol should **not** be used.

(1)

.....

.....

.....

(Total for question = 1 mark)

Edexcel Chemistry A-level - Halogenoalkanes

Q12.

The following procedure may be used to prepare 2-chloro-2-methylpropane.

- Step 1** Place 15 cm³ of 2-methylpropan-2-ol in a separating funnel and slowly add 30 cm³ of concentrated hydrochloric acid (an excess), while swirling the funnel.
- Step 2** When all the hydrochloric acid has been added, leave the mixture to stand for 20 minutes, shaking it gently at intervals.
- Step 3** Once the organic and aqueous layers have completely separated, discard the aqueous layer.
- Step 4** Add saturated sodium hydrogencarbonate solution, a little at a time, to the organic layer. After each addition, invert the separating funnel and open the tap.
- Step 5** Discard the aqueous layer.
- Step 6** Transfer the organic layer to a small flask, add a solid drying agent and swirl the flask.
- Step 7** Decant the liquid into a clean flask and distil it to collect pure 2-chloro-2-methylpropane.

Some data on the organic reactant and product are given in the table.

| Data | 2-methylpropan-2-ol | 2-chloro-2-methylpropane |
|----------------------------------|---------------------|--------------------------|
| molar mass / g mol ⁻¹ | 74.0 | 92.5 |
| boiling temperature / °C | 82 | 51 |
| density / g cm ⁻³ | 0.79 | 0.84 |

- (a) Draw a diagram of a separating funnel, labelling the aqueous layer and the layer of 2-chloro-2-methylpropane that would be observed at the end of **Step 2**.

(2)

- (b) Give the reason why sodium hydrogencarbonate solution is added to the organic layer in **Step 4** and why it is important to open the tap after adding this solution.

(2)

.....

.....

.....

Edexcel Chemistry A-level - Halogenoalkanes

(c) Which **one** of these anhydrous compounds may be used as a drying agent in **Step 6**?

(1)

- A** sodium chloride
- B** sodium hydroxide
- C** sodium nitrate
- D** sodium sulfate

(d) A student set up this apparatus for distillation in **Step 7** as shown.

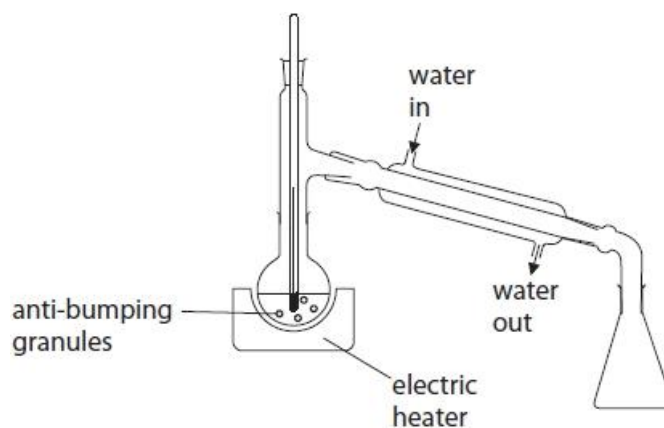

(i) Describe **three** ways in which this apparatus must be modified for safe and efficient use. Assume the apparatus is suitably clamped.

(3)

.....

.....

.....

.....

.....

.....

.....

.....

.....

.....

(ii) Give a suitable temperature range over which to collect the final product during the distillation.

(1)

.....

Edexcel Chemistry A-level - Halogenoalkanes

(e) In the preparation, 15cm^3 of 2-methylpropan-2-ol produced 6.9cm^3 of 2-chloro-2-methylpropane.

The equation for the reaction is

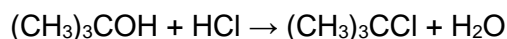

Calculate the percentage yield of 2-chloro-2-methylpropane, using data from the table.

| Data | 2-methylpropan-2-ol | 2-chloro-2-methylpropane |
|----------------------------------------|---------------------|--------------------------|
| molar mass / g mol^{-1} | 74.0 | 92.5 |
| boiling temperature / $^\circ\text{C}$ | 82 | 51 |
| density / g cm^{-3} | 0.79 | 0.84 |

(3)

(f) The mechanism for the reaction is in three stages.

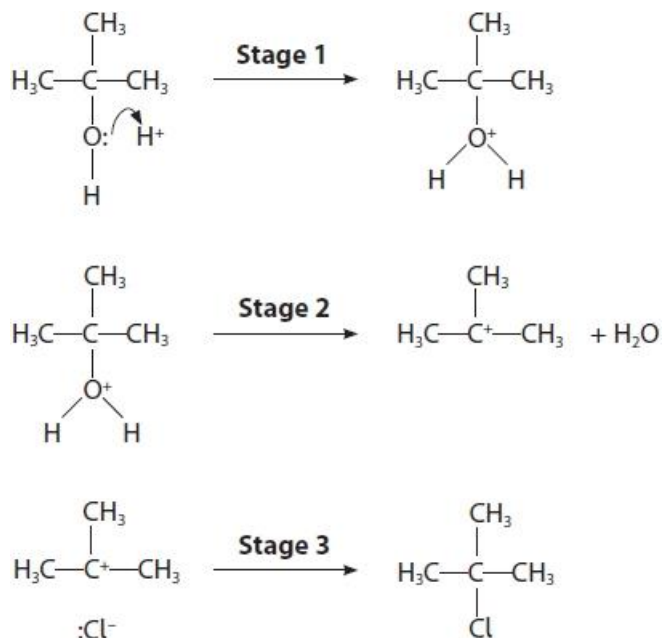

Add curly arrows to the reactants in **Stages 2** and **3** to complete the mechanism.

(2)

(Total for question = 14 marks)

Edexcel Chemistry A-level - Halogenoalkanes

Q13.

Answer the question with a cross in the box you think is correct . If you change your mind about an answer, put a line through the box and then mark your new answer with a cross .

Bromobutanes react with hot ethanolic potassium hydroxide solution to produce gaseous butenes.

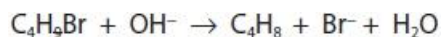

Apparatus

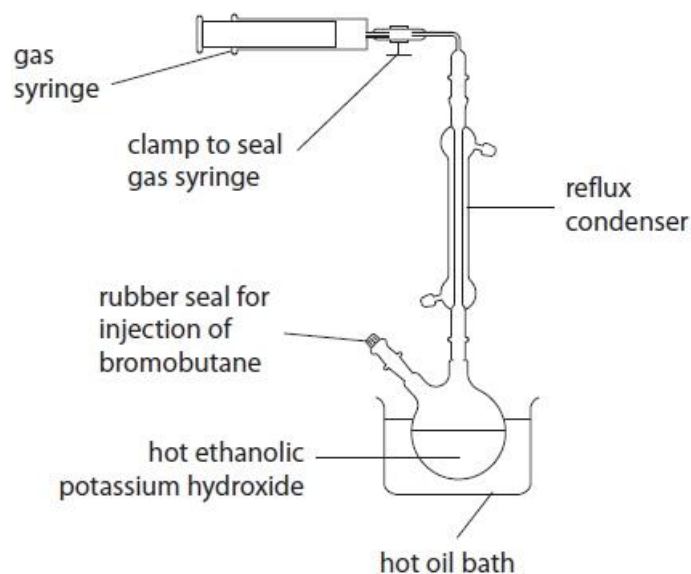

Procedure

- 0.0080 mol of liquid 1-bromobutane was injected into a round bottom flask containing hot ethanolic potassium hydroxide.
- After the reaction, the syringe was sealed using a clamp.
- The syringe was then removed from the apparatus and allowed to cool to room temperature (298 K).

Result

The final volume of but-1-ene collected was 22.0 cm³.

- (i) Another compound formed from 1-bromobutane under these conditions is butan-1-ol. Identify the type of reaction taking place to form butan-1-ol.

(1)

.....

Edexcel Chemistry A-level - Halogenoalkanes

(ii) The functional group in butan-1-ol can be confirmed using a single chemical test.

What is the single chemical test and expected observation?

(1)

| | Chemical test reagent | Observation |
|----------------------------|---------------------------|-------------------|
| <input type="checkbox"/> A | sodium carbonate solution | effervescence |
| <input type="checkbox"/> B | aqueous silver nitrate | cream precipitate |
| <input type="checkbox"/> C | Fehling's solution | red precipitate |
| <input type="checkbox"/> D | phosphorus(V) chloride | steamy fumes |

(iii) Draw the mechanism for the reaction of 1-bromobutane with hydroxide ions to form butan-1-ol.

Include curly arrows, and any appropriate lone pairs and dipoles.

(3)

(Total for question = 5 marks)

Edexcel Chemistry A-level - Halogenoalkanes

Q14.

Answer the question with a cross in the box you think is correct . If you change your mind about an answer, put a line through the box and then mark your new answer with a cross .

This question is about halogenoalkanes.

2-chloro-2-methylpropane can be hydrolysed by water.

The equation for this reaction is

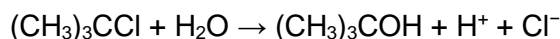

The graph shows how the concentration of 2-chloro-2-methylpropane changes with time during an investigation of this reaction.

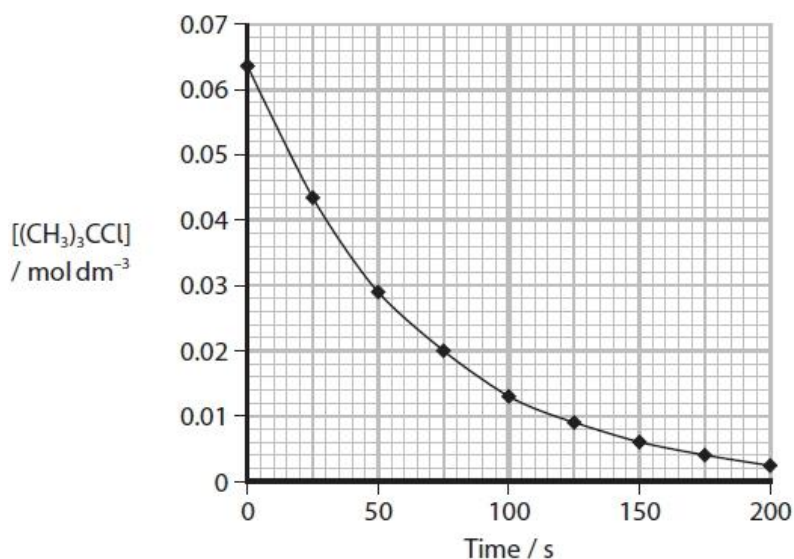

The letters X, Y and Z refer to three different halogenoalkanes:

- X 1-bromobutane
- Y 2-bromobutane
- Z 2-bromo-2-methylpropane

1 cm³ of each of these halogenoalkanes was added to separate test tubes containing 5 cm³ of ethanol and 5 cm³ of aqueous silver nitrate solution in a water bath at 50 °C.

(i) State the visible change in the reaction of an ethanol/silver nitrate solution with halogenoalkane X.

Include the **formula** of the compound responsible for this observation.

(2)

.....

(ii) The three halogenoalkanes were placed in order of **decreasing** rate of reaction. Which is the correct sequence?

(1)

- A X, Z, Y
- B Z, X, Y
- C Z, Y, X
- D X, Y, Z

(Total for question = 3 marks)

Edexcel Chemistry A-level - Halogenoalkanes

Q15.

Answer the question with a cross in the box you think is correct . If you change your mind about an answer, put a line through the box and then mark your new answer with a cross .

1-chloropropane and 2-chloropropane can be converted into compounds containing the nitrile functional group.

(i) Under appropriate conditions, 1-chloropropane can be converted into butanenitrile, $\text{CH}_3\text{CH}_2\text{CH}_2\text{CN}$.

Which is the reagent for this conversion?

- A ammonia
- B nitric acid
- C potassium cyanide
- D silver nitrate

(1)

(ii) Under appropriate conditions, 2-chloropropane can be converted into a structural isomer of butanenitrile.

State what is meant by the term 'structural isomer'.

(2)

.....

.....

.....

.....

(iii) Give the displayed formula **and** systematic name of the isomer of butanenitrile formed in (ii).

You must show **all** the bonds.

(2)

Displayed formula

Name

.....

(Total for question = 5 marks)

Edexcel Chemistry A-level - Halogenoalkanes

Q16.

This is a question about halogenoalkanes and related compounds.

Explain the trend in reactivity of the **primary** chloro-, bromo- and iodoalkanes with aqueous hydroxide ions.

(2)

.....

.....

.....

.....

(Total for question = 2 marks)

Edexcel Chemistry A-level - Halogenoalkanes

Q17.

This question is about halogenoalkanes.

2-chloro-2-methylpropane can be hydrolysed by water.

The equation for this reaction is

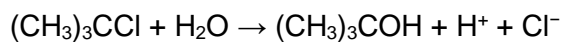

The graph shows how the concentration of 2-chloro-2-methylpropane changes with time during an investigation of this reaction.

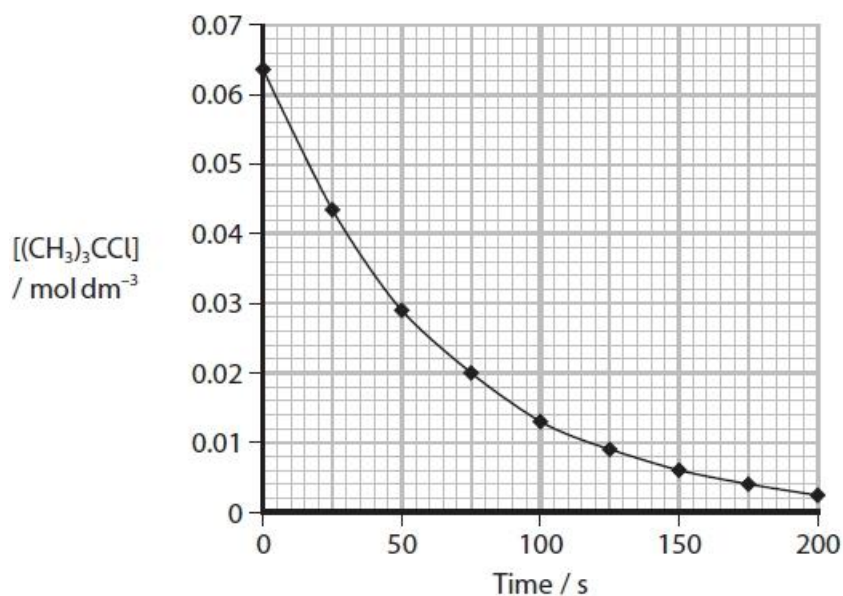

Under different conditions, 2-chloro-2-methylpropane can react to produce 2-methylpropene, $(\text{CH}_3)_2\text{C}=\text{CH}_2$.

(i) State the reagent and conditions needed for this reaction.

(2)

.....

.....

(ii) Draw the displayed formula for the repeat unit of a polymer that is made by the polymerisation of 2-methylpropene, $(\text{CH}_3)_2\text{C}=\text{CH}_2$.

(1)

Edexcel Chemistry A-level - Halogenoalkanes

(iii) Draw a mechanism for the addition of hydrogen bromide, HBr, to 2-methylpropene to form 2-bromo-2-methylpropane.
Include curly arrows, and any relevant dipoles and lone pairs.

(4)

(Total for question = 7 marks)

Edexcel Chemistry A-level - Halogenoalkanes

Q18.

This is a question about the hydrolysis of halogenoalkanes.

Explain the trend in the rates of hydrolysis of 1-chlorobutane, 1-bromobutane and 1-iodobutane.

(2)

.....

.....

.....

.....

.....

.....

(Total for question = 2 marks)

Edexcel Chemistry A-level - Halogenoalkanes

Q19.

This is a question about halogenoalkanes and related compounds.

In aqueous sodium hydroxide, 1-bromoethane reacts to produce ethanol.

(i) Write the mechanism for this reaction, including all relevant curly arrows, lone pairs and dipoles. Include the transition state.

(4)

(ii) Give the reagents that are used to test that bromide ions are formed in this reaction mixture. Include the result of the test.

(2)

.....

.....

.....

.....

(Total for question = 6 marks)

Edexcel Chemistry A-level - Halogenoalkanes

Q20.

This question is about the arenes, ethylbenzene, xylene, and phenol, which can be identified in wine samples using gas chromatography.

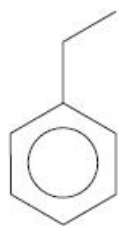

ethylbenzene

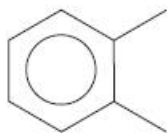

xylene

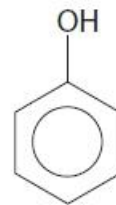

phenol

Ethylbenzene can be formed by the reaction of a chloroalkane with benzene, catalysed by aluminium chloride, AlCl_3 .

(i) Draw the **displayed** formula of the chloroalkane required for this reaction.

(1)

(ii) Draw the mechanism for this reaction.

Include equations showing the role of the catalyst and how it is regenerated.

(5)

Edexcel Chemistry A-level - Halogenoalkanes

(iii) Explain whether phenol is likely to be less or more reactive than benzene with the chloroalkane from (i).

(3)

.....

.....

.....

.....

.....

.....

.....

.....

(Total for question = 9 marks)

Edexcel Chemistry A-level - Halogenoalkanes

Q21.

Halogenoalkanes react with water to produce alcohols and halide ions.



(a) Test tube experiments can be carried out to investigate the relative rates of these substitution reactions.

The halogenoalkanes 1-chlorobutane, 1-bromobutane and 1-iodobutane can be used. Some of the steps in these experiments are

- each halogenoalkane is added to a different tube containing 1 cm³ of ethanol
- the test tubes are placed in the same beaker of hot water
- aqueous silver nitrate is added to each tube and the tubes are shaken
- a precipitate forms in each tube.

(i) State the purpose of adding ethanol to each of the test tubes.

(1)

.....

.....

.....

(ii) Give **one** reason why the test tubes were put in the same beaker of hot water.

(1)

.....

.....

.....

(iii) Give **one** reason why the test tubes were shaken after the addition of aqueous silver nitrate.

(1)

.....

.....

.....

(b) (i) State how the halogen atom present in each halogenoalkane can be identified using observations from this experiment in (a).

(1)

.....

.....

.....

.....

.....

Edexcel Chemistry A-level - Halogenoalkanes

(ii) Identify further reagents that can be added, including relevant observations, to confirm the identity of the halogen atom present in each halogenoalkane.

(2)

.....

.....

.....

.....

.....

*(c) Outline the method for a test tube experiment, **which expands on the steps in (a)**, to investigate how the rate of the substitution reaction depends on whether the halogenoalkane is primary, secondary or tertiary.

Your experiment should test a series of isomeric bromoalkanes reacting with water.
Your plan should include

- the chemicals you will use
- an outline of how the experiment will be carried out
- the observations or measurements you will make and how you will interpret them.

(6)

(Total for question = 12 marks)

Edexcel Chemistry A-level - Halogenoalkanes

Q22.

A bromoalkane, RBr, reacts with aqueous hydroxide ions in a nucleophilic substitution reaction.

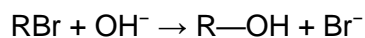

This reaction is first order with respect to the bromoalkane and the rate equation is

$$\text{rate} = k[\text{RBr}]^1[\text{OH}^-]^x$$

where x is the order of the reaction with respect to hydroxide ions.

In an experiment, a sample of the bromoalkane was added to a large excess of aqueous sodium hydroxide and the concentration of the bromoalkane was determined at regular time intervals.

Results

| Time / s | [RBr] / mol dm ⁻³ |
|----------|------------------------------|
| 0 | 0.100 |
| 30 | 0.065 |
| 60 | 0.042 |
| 90 | 0.028 |
| 120 | 0.019 |
| 150 | 0.014 |

The experiment was repeated using equal concentrations of RBr and varying the concentration of hydroxide ions.

A graph was plotted of the results.

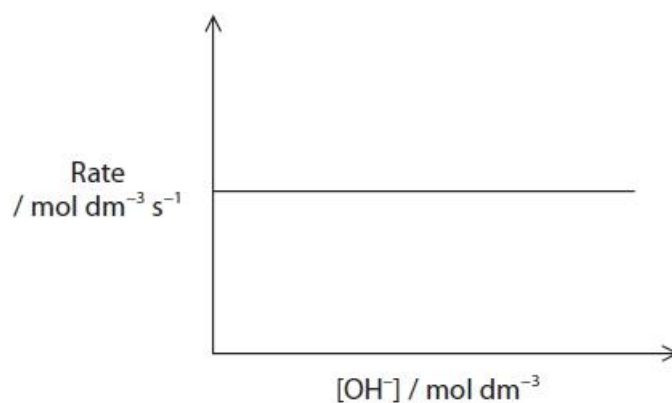

Edexcel Chemistry A-level - Halogenoalkanes

- (i) Deduce the value of x in the rate equation.

$$\text{rate} = k[\text{RBr}]^1[\text{OH}^-]^x$$

(1)

-
- (ii) Give the mechanism for the reaction that is consistent with the orders of reaction with respect to R—Br and hydroxide ions.

Include curly arrows and relevant lone pairs.

(3)

(Total for question = 4 marks)

Edexcel Chemistry A-level - Halogenoalkanes

Q23.

2-bromobutane can react with aqueous hydroxide ions by an S_N1 mechanism.

Explain why the butan-2-ol produced from a single optical isomer of 2-bromobutane, using this mechanism, is **not** optically active.

(3)

.....

.....

.....

.....

.....

.....

.....

.....

.....

.....

(Total for question = 3 marks)

Mark Scheme

Q1.

| Question Number | Acceptable Answer | Additional Guidance | Mark |
|-----------------|----------------------------------------------------------------------------------------------------------------------------------------------------------------------------------------------------------------------------|--------------------------------------------------------------------------------------------------------------------------------------------------------------------------------|------------|
| (i) | Reagent • (concentrated) NaOH/KOH (1) Conditions • ethanol (solvent) <u>and</u> heat/warm (1) | do not award OH ⁻ or just 'hydroxide' do not award M1 if 'acidified' allow reflux M2 is dependent on M1 except for a near miss e.g. OH ⁻ | (2) |
| Question Number | Acceptable Answer | Additional Guidance | Mark |
| (ii) | • Reagent: KCN/NaCN /potassium cyanide / sodium cyanide (1) • Reason: increases the number of carbon atoms in the carbon chain/ length of carbon chain (1) | ignore any mention of the solvent (aq ethanol) and conditions (reflux) do not award just CN ⁻ /cyanide/HCN | (2) |
| Question Number | Acceptable Answer | Additional Guidance | Mark |
| (iii) | An explanation that makes reference to the following: • heating increases rate (of reaction) (1) • no sealed tube would result in loss of ammonia (gas)/ reactants / gas (1) | ignore reference to activation energy/ starting the reaction/ reaction is endothermic ignore toxicity of reactants | (2) |
| Question Number | Acceptable Answer | Additional Guidance | Mark |
| (iv) | $\text{CH}_3 - \text{CH}_2 - \text{CH}_2 - \text{OH}$ | allow displayed/structural/skeletal formula ignore name do not award just C ₃ H ₇ OH | (1) |

Edexcel Chemistry A-level - Halogenoalkanes

Q2.

| Question Number | Answer | Mark |
|-----------------|--------------------------------------------------------------------------------------------------------------------------------------------------------------------------------------------------------------------------------------------------------------------------------------------------------------------------------------------------------------------------------------|------|
| (a)(i) | <p>The only correct answer is B</p> <p><i>A is not correct because X,Y,Z is chloro/bromo/iodo, and would be for increasing rate not time taken</i></p> <p><i>C is not correct because Y,X,Z is bromo/chloro/iodo, ie incorrect for rate or time taken</i></p> <p><i>D is not correct because Z,X,Y is iodo/chloro/bromo, also incorrect for either rate or time taken</i></p> | (1) |

| Question Number | Acceptable Answer | Additional Guidance | Mark |
|-----------------|----------------------------------------------------------------------------------------------------------|-----------------------------------------------------------------------------------------------------------------------------------------------------------------------------------------------------------------------------------------------------------------------------------------------------------------------|------|
| (a)(ii) | to increase the solubility of / dissolves the halogenoalkane /reactants / so that reactants are miscible | <p>Do not award just 'as a good solvent'</p> <p>Allow cosolvent / as a (good) solvent for both reactants</p> <p>Ignore 'stop formation of layers'</p> <p>Ignore 'to allow mixing'</p> <p>Comment Water, aqueous silver nitrate and just silver nitrate are all acceptable alternatives for the other reactant</p> | (1) |

| Question Number | Acceptable Answer | Additional Guidance | Mark |
|-----------------|---------------------------------------------------------------------------------------------------------------|----------------------------------------------------------------------------------------------------------------------------------|------|
| (a)(iii) | to allow the solutions to equilibrate / reach the same temperature /reach 50°C/reach the required temperature | <p>Do not award to keep temperature constant</p> <p>Ignore references to reaction rates</p> <p>Ignore reference to fair test</p> | (1) |

| Question Number | Acceptable Answer | Additional Guidance | Mark |
|-----------------|------------------------------------------------------------------------------------------------------------------------------------------------------------------------------------------------------------------------------------------------|----------------------------------------------------------------------------------------------------------------------------------------------------------------------------------------------------------------------------------|------|
| (a)(iv) | <p>an explanation that makes reference to the following points:</p> <ul style="list-style-type: none"> (the halogenoalkane is) hydrolysed by water (1) C- Hal bond breaks (heterolytically producing ions) (1) | <p>reward recognition of reaction with water</p> <p>Do not award reaction with OH⁻</p> <p>Comment Must be clear that the C- Hal bond is breaking. Allow statements like 'the halogen ion / halide breaks off'</p> | (2) |

Edexcel Chemistry A-level - Halogenoalkanes

| Question Number | Acceptable Answer | Additional Guidance | Mark |
|-----------------|-------------------------------------------------------------------------------------|---------------------------------------------------------------------------------------------------------|------|
| (a)(v) | $\text{Ag}^+(\text{aq}) + \text{Cl}^-(\text{aq}) \rightarrow \text{AgCl}(\text{s})$ | Ignore previous workings. Mark the final equation. Do not award uncancelled spectator ions | (1) |

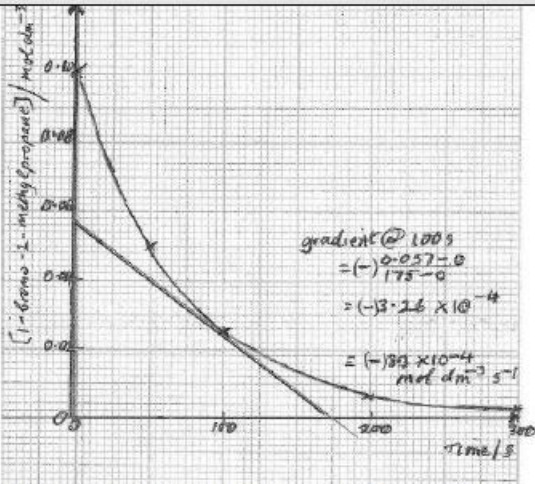
| Question Number | Acceptable Answer | Additional Guidance | Mark |
|-----------------|---------------------------------------------------------------------------------------------------------------------------------------------------------------------------------------------------------------|-------------------------------------------------------------------------------------------------------------------------------------------------------------------------------------------------------------------------------------------------------------------------------------------------------------------------------------------------------------------------------------------------------------------------------------------------------------------------------------------------------------------------------------------------------------------------------------------------------------|------|
| (b)(i) | <p>Graph: both axes labelled and graph covering at least half the grid in both directions. (1)</p> <p>points plotted correctly (1)</p> <p>smooth line of best fit (1)</p> |  <p>Do not award 1-bromo-2-methylpropane without [] Do not award just 'concentration/mol dm⁻³' Allow 'concentration of 1-bromo-2-methylpropane/mol dm⁻³' Units required on both axes Accept / between label and mol dm⁻³ or (mol dm⁻³)</p> <p>Non-linear scale on either axis loses M1 and M2 but can get M3 for a smooth curve based on their points</p> <p>Reversed axes loses M1 only Accuracy ± ½ small square Do not award dot-to-dot lines</p> | (1) |

| Question Number | Acceptable Answer | Additional Guidance | Mark |
|-----------------|---------------------------------------------------------------------------------------------------------------------------------------------------------------------------------------------------------------------------------------------|-------------------------------------------------------------------------------------------------------------------------------------------------------------------------------------------------------------------------------------------------------------------------------------------------------------------|------|
| (b)(ii) | <p>line drawn as tangent to curve at time 100 s. (1)</p> <p>gradient= (-)3.3 x 10⁻⁴ (allow range (-)2.5 x 10⁻⁴ to (-)4.5 x 10⁻⁴) (1)</p> <p>mol dm⁻³ s⁻¹ (1)</p> | <p>ignore missing negative sign. Allow any SF except 1 Do not award answers that use only the one point at 100s Example 0.0250/100 = 2.5 x 10⁻⁴ Do not award for gradient of a straight line graph Do not award for gradient as a fraction</p> <p>Allow mol dm⁻³ /s</p> | (3) |

Edexcel Chemistry A-level - Halogenoalkanes

| Question Number | Answer | Mark |
|-----------------|-------------------------------------------------------------------------------------------------------------------------------------------------------------------------------------------------------------------------------------------------------------------------------------------------------------------------------------------------------------------------------------------------------------------------------------------|------|
| (c)(i) | <p>The only correct answer is D</p> <p>A is not correct because the OH^- ion is consumed, therefore not acting as a catalyst</p> <p>B is not correct because the OH^- ion has negative charge and will not act as an electrophile</p> <p>C is not correct because the OH^- ion does not have a single unpaired electron therefore not a free radical</p> | (1) |

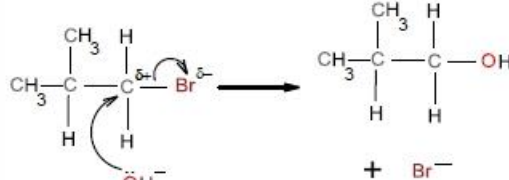
| Question Number | Acceptable Answer | Additional Guidance | Mark |
|-----------------|-------------------------------------------------------------------------------------------------------------------------------------------------------------------------------------------------------------------------------------------------------------------------------------------------------------------------------------------------------------------|------------------------------------------------------------------------------------------------------------------------------------------------------------------------------------------------------------------------------------------------------------------------------------------------------------------------------------------------------------------------------|------|
| (c)(ii) | <p>correct structure of 1-bromo-2-methylpropane (1)</p> <p>dipole on C – Br bond, i.e. $\delta+$ and $\delta-$ (1)</p> <p>lone pair shown on OH^- and curly arrow from lone pair on OH^- to correct carbon (1)</p> <p>curly arrow from C-Br bond to Br and correct products (1)</p> |  <p>$\text{S}_{\text{N}}2$ mechanism M1, M2 and M4 still available for $\text{S}_{\text{N}}1$ mechanism</p> <p>TE for any other halogenoalkane, M2, M3 and M4 still available</p> <p>Lone pair must be located (anywhere) on the O atom of the hydroxide ion</p> | (4) |

| Question Number | Acceptable Answer | Mark |
|-----------------|------------------------------------------------------------------------------------------------------------------------------------------------------------------------------------------------------------------------------------------------------------------------------------------------------------------------------------------------------|------|
| (c)(iii) | <p>The only correct answer is D</p> <p>A is not correct because addition involves the joining together of two molecules to make a bigger one</p> <p>B is not correct because elimination involves the loss of a small molecule during the reaction</p> <p>C is not correct because there are no changes in oxidation number</p> | 1 |

Edexcel Chemistry A-level - Halogenoalkanes

Q3.

| Question Number | Acceptable Answer | Additional guidance | Mark |
|-----------------|--------------------------------------------------------------------------------------------------------------------------------------------------------------------------------------------------------------------------------------------------------------------------------------------------------------------------------------------------------------------------------------------------------------------------------------------------------------------------------------|------------------------------------------------------------------------------------------------------------------------------------------------------------------------------------------------------------------------------------------------------------------------------------------------------------------------------------------------------------------------------------------------------------------------------------------------------------------------------------------------------------------------------------------------------------|-------------------|
| | <p>An answer that gives reference to the following</p> <ul style="list-style-type: none"> • (M1) use of ethanol (as a solvent) (1) • (M2) use of silver nitrate (solution) (1) • (M3) equal amounts used of each halogenoalkane (1) • (M4) measure the time taken for precipitate to form (1) • (M5) use a water bath (to control a raised temperature) (1) | <p>Allow "alcohol"</p> <p>Do not award ammoniacal silver nitrate Ignore use of nitric acid</p> <p>Allow equal volumes/equal stated volumes</p> <p>Allow "time for cross to disappear" Do not award for a colour to form. M4 dependent on M2 or near miss.</p> <p>If hydroxide (ions) used for hydrolysis then measuring the reaction is too quick, so no M4. The solution would need to be acidified before the addition of silver nitrate if M2 is to be awarded. If hydrochloric acid is used, then only M1, M3 and M5 can be scored</p> | <p>(5)</p> |

Edexcel Chemistry A-level - Halogenoalkanes

Q4.

| Question Number | Acceptable Answers | Additional Guidance | Mark |
|-----------------|------------------------------------------------------------------|----------------------------------------------------------------------------------------------------------------------------------------------------------------------------------------------------------------------------------------------------------------------------------------------------------------------------------------------------------------------------------------------------------------------------------------------------------------------------------------------------------------------------------------------------------------------------------------------------------------------------------------------------------------------------------------------------------------------------------------------|------|
| (i) | <ul style="list-style-type: none"> ionic equation | <p><u>Example of equation:</u> $\text{CH}_3\text{CH}_2\text{CHBrCH}_3 + \text{OH}^- \rightarrow \text{CH}_3\text{CH}_2\text{CHOHCH}_3 + \text{Br}^-$</p> <p>Allow $\text{CH}_3\text{CH}_2\text{CHBrCH}_3 + \text{H}_2\text{O} \rightarrow \text{CH}_3\text{CH}_2\text{CHOHCH}_3 + \text{H}^+ + \text{Br}^-$</p> <p>Allow displayed /skeletal formulae or any combination of these formulae provided the correct organic molecules are shown</p> <p>Ignore any working before the final equation, even if not crossed out</p> <p>Ignore equation with molecular formulae</p> <p>Ignore state symbols, even if incorrect</p> <p>Do not allow just an equation with uncanceled K^+ ions</p> | (1) |

| Question Number | Acceptable Answers | Additional Guidance | Mark | | | | | | | | | | | | |
|----------------------------------------------------|---------------------------------------------------------------------------------------------------------------------------------------------------------------------------------------------------------------------------------------------------------------------------------------------------------------------------------------------------------------------------------------------------------------------------------------------------------------------------------------------------------------------------------------------------------------------------------------------------------------------------------------------------------------------------------------------------------------------------------------------------------------------------------------------------------------------------------------------------------------------------------|----------------------------------------------------|-------------------------------------------------------|---|---|-----|---|-----|---|---|---|---|---|---------------------------------------------------------------------------------------------------------------------------------------------------------------------------------------------------------------------------------------------------------------------------------------------------------------------------------------------------------------------------------------------------------------------------------------------------------------------------------------------------------------------------------------------------------------------------------------------------------------|-----|
| *(ii) | <p>This question assesses a student's ability to show a coherent and logically structured answer with linkages and fully-sustained reasoning.</p> <p>Marks are awarded for indicative content and for how the answer is structured and shows lines of reasoning.</p> <p>The following table shows how the marks should be awarded for indicative content.</p> <table border="1" data-bbox="395 1391 810 1682"> <thead> <tr> <th>Number of indicative marking points seen in answer</th> <th>Number of marks awarded for indicative marking points</th> </tr> </thead> <tbody> <tr> <td>6</td> <td>4</td> </tr> <tr> <td>5-4</td> <td>3</td> </tr> <tr> <td>3-2</td> <td>2</td> </tr> <tr> <td>1</td> <td>1</td> </tr> <tr> <td>0</td> <td>0</td> </tr> </tbody> </table> <p>The following table shows how the marks should be awarded for structure and lines of reasoning.</p> | Number of indicative marking points seen in answer | Number of marks awarded for indicative marking points | 6 | 4 | 5-4 | 3 | 3-2 | 2 | 1 | 1 | 0 | 0 | <p>Guidance on how the mark scheme should be applied:</p> <p>The mark for indicative content should be added to the mark for lines of reasoning. For example, an answer with five indicative marking points that is partially structured with some linkages and lines of reasoning scores 4 marks (3 marks for indicative content and 1 mark for partial structure and some linkages and lines of reasoning).</p> <p>If there are no linkages between points, the same five indicative marking points would yield an overall score of 3 marks (3 marks for indicative content and no marks for linkages).</p> | (6) |
| Number of indicative marking points seen in answer | Number of marks awarded for indicative marking points | | | | | | | | | | | | | | |
| 6 | 4 | | | | | | | | | | | | | | |
| 5-4 | 3 | | | | | | | | | | | | | | |
| 3-2 | 2 | | | | | | | | | | | | | | |
| 1 | 1 | | | | | | | | | | | | | | |
| 0 | 0 | | | | | | | | | | | | | | |

Edexcel Chemistry A-level - Halogenoalkanes

| | | Number of marks awarded for structure of answer and sustained line of reasoning | | |
|--|-------------------------------------------------------------------------------------------------------------------------------------------------------------------------------------------------------------------------------------------------------------------------------------------------------------------------------------------------------------------|---------------------------------------------------------------------------------|-------------------------------------------------------------------------------------------------------------------------------------------------------------------------------------------------------------------------------------------------------------------------------------------------------------------------------------------------------------------------------------------------------------------------------------------------------------------------------------------------------------------------------------------------------------------------|--|
| | Answer shows a coherent and logical structure with linkages and fully sustained lines of reasoning demonstrated throughout. | 2 | <p>In general it would be expected that 5 or 6 indicative points would get 2 reasoning marks, and 3 or 4 indicative points would get 1 mark for reasoning, and 0, 1 or 2 indicative points would score zero marks for reasoning.</p> <p>If there is any incorrect chemistry, deduct marks from the reasoning mark, for example:</p> <p>If a hydroxide solution is used, deduct 1 mark from reasoning mark If colours of precipitates are incorrect, deduct 1 mark from reasoning mark</p> <p>Allow description of experiment from a labelled diagram</p> | |
| | Answer is partially structured with some linkages and lines of reasoning. | 1 | | |
| | Answer has no linkages between points and is unstructured. | 0 | | |
| | <p>Comment: Look for the indicative marking points first, then consider the mark for structure of answer and sustained line of reasoning</p> <p>Indicative content</p> <ul style="list-style-type: none"> Ethanol – use of ethanol as a solvent (added to each halogenoalkane / liquid in separate containers) | | | |

Edexcel Chemistry A-level - Halogenoalkanes

| | | | |
|--|------------------------------------------------------------------------------------------------------------------------------------------------------------------------------------------------------------------------------------------------------------------------------------------------------------------------------------------------------------------------------------------------------------------------------------------------------------------------------------------------------------------------------------------------------------------------------------------------------------------------------------------------------------------------------------------------------------------------------------------------------------------------------------------------------------------------------------------------------------------------------------------------------------------------------------------------------------------------------------------------------------------|-----------------------------------------------------------------------------------------------------------------------------------------------------------------------------------------------------------------------------------------------------------------------------------------------------------------------------------------------------------------------------------------------------------------------------------------------------------------------------------------------------------------------------------------------------------------------------------------------------------------------------------|--|
| | <ul style="list-style-type: none"> • Fair test – use of equal volumes/amounts / specified volumes/amounts in each tube or warm the tubes in a water bath / specified temperature / room temperature • Silver nitrate - silver nitrate (solution) / $\text{Ag}^+(\text{aq})$ to each tube (of halogenoalkane) • Time - find the time taken for a precipitate to form • Rate - expected trend is 2-iodobutane > 2-bromobutane > 2-chlorobutane or 2-iodobutane is the fastest <u>and</u> 2-chlorobutane is the <u>slowest</u> • Bond enthalpy - bond enthalpy $\text{C-I} < \text{C-Br} < \text{C-Cl}$ / decreases from C-Cl to C-I / C-Cl is the strongest <u>and</u> C-I is the weakest / C-X bond strength decreases down the group (of halogens) | <p>Ignore nitric acid / HNO_3</p> <p>Allow find how quickly the precipitates form</p> <p>Allow time taken for 2-iodobutane < 2-bromobutane < 2-chlorobutane Allow I^- forms first, Cl^- forms last Allow the halogenoalkanes get more reactive from chloro to iodo / 'down the group' Allow reverse trends</p> <p>Allow 'the bond enthalpy decreases down the group' or a comparison of bond enthalpy in 2-iodobutane and 2-chlorobutane</p> <p>Ignore references to bond length / bond polarity / electronegativity / effective nuclear charge</p> | |
|--|------------------------------------------------------------------------------------------------------------------------------------------------------------------------------------------------------------------------------------------------------------------------------------------------------------------------------------------------------------------------------------------------------------------------------------------------------------------------------------------------------------------------------------------------------------------------------------------------------------------------------------------------------------------------------------------------------------------------------------------------------------------------------------------------------------------------------------------------------------------------------------------------------------------------------------------------------------------------------------------------------------------|-----------------------------------------------------------------------------------------------------------------------------------------------------------------------------------------------------------------------------------------------------------------------------------------------------------------------------------------------------------------------------------------------------------------------------------------------------------------------------------------------------------------------------------------------------------------------------------------------------------------------------------|--|

Edexcel Chemistry A-level - Halogenoalkanes

Q5.

| Question Number | Answer | Additional Guidance | Mark |
|-----------------|-------------------------------------------------------------------------------------------------------------------------------------------------------------------------------------------------------------------------------------------------------------------------|---------------------------------------------------------------|------|
| (a) | <ul style="list-style-type: none"> M1 axes labelled with units on axes, suitable uniform scale with points covering at least half the available space in both directions (1) M2 all points plotted correctly with straight line of best fit (1) | <p>Example of graph</p> <p>Allow variables on either axis</p> | (2) |

| Question Number | Answer | Additional Guidance | Mark |
|-----------------|-------------------------------------------------------------------------------------------------------------------------------------------------------------------------------------------------------------------------------------------------------------------------------------------|---------------------|------|
| (b) | <p>An answer that makes reference to the following points</p> <ul style="list-style-type: none"> zero order with respect to hydroxide ions (1) The graph is a straight line so the rate of reaction is independent of the concentration of the hydroxide ions (1) | M2 dependent on M1 | (2) |

| Question Number | Answer | Additional Guidance | Mark |
|-----------------|--------------------------------------------------------------------------------------------------------------------------------------------------------------------------------------------------------------------------------------------------------------|------------------------------------------------------------------------------------------------------------------|------|
| (c) | <p>An answer that makes reference to the following points</p> <ul style="list-style-type: none"> S_N1 (1) as there is only one reactant in the rate determining step / as the hydroxide ions do not affect the rate (1) | <p>Mark consequentially on order</p> <p>Allow TE from (b) e.g. if first order in (b) allow S_N2</p> | (2) |

Edexcel Chemistry A-level - Halogenoalkanes

| Question Number | Answer | Additional Guidance | Mark |
|-----------------|--------------------------------------------------------------------------------|----------------------------------------------------------------------------------------------------------------------------------------------------------------------------------------------------------------|------|
| (d) | <ul style="list-style-type: none"> the chloroalkane is tertiary | Allow TE from first order in (b) and/or S_N2 in (c) e.g. if S_N2 in (c) allow primary NOTE if first order wrt hydroxide ions in (b) but S_N1 given in (c) can score 1 mark in (d) for tertiary | (1) |

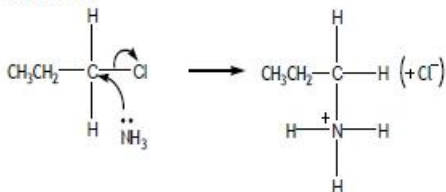
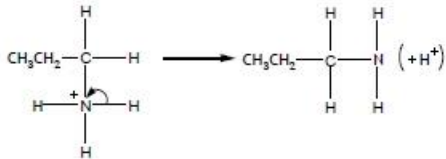
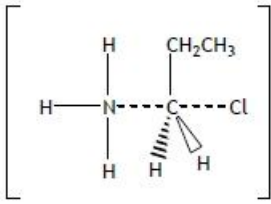

Q6.

| Question Number | Acceptable Answers | Additional Guidance | Mark |
|-----------------|---------------------------------------------------------------------------------------------------------------------------------------------------------------------------------------------------------------------------------------------------------|-------------------------------------------------------------------------------------------------------------------------------------------------------------------------------------------------------------------------------------------------------------------------------------------------------------------------------------------------------------------------------------------------------------------------------------------------------------------------------|------|
| | <ul style="list-style-type: none"> first two curly arrows and lone pair shown on the nitrogen (1) structure of intermediate including positive charge (1) third curly arrow and formation of final organic product (1) | Ignore correct dipoles Allow non-displayed NH_3^+ for MP2 Ignore involvement of Cl^- / NH_3 or wrong inorganic products for MP3 EITHER   Ignore depiction of transition state e.g.  | (3) |

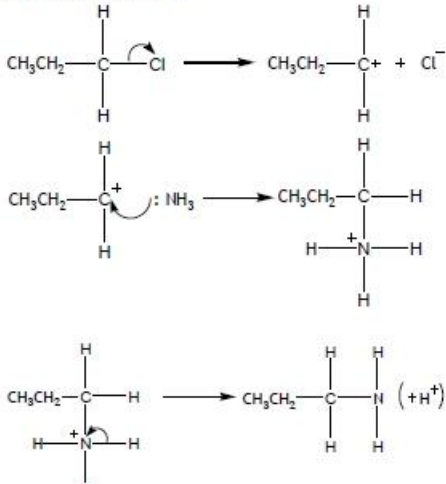
Edexcel Chemistry A-level - Halogenoalkanes

| | | | |
|--|-----------------------------------------------------------------------------------------------------------------------------------------------------------------------------------------------------------------------------------------------------------------------------------------------------------------------------------------------------------------------------------------------------------------------|---------------------------------------------------------------------------------------------------------------------------------------------------------------------------------------------------------------------------------------------------------------------------------------------------------------------------------------------------------------------------------------------------------------------------------------------------------------------------------------------------------------------------------------------------------------------------------------------------|--|
| | <p>OR</p> <ul style="list-style-type: none"> fission of C-Cl bond curly arrow and curly arrow from nitrogen in NH₃ with lone pair shown on N atom to correct carbocation (1) structure of resulting nitrogen-containing intermediate including positive charge (1) curly arrow resulting in breaking of an N-H bond and structure of the final organic product (1) | <p>OR AWARD S_N1 mechanism</p>  <p>CH₃CH₂-C(H)₂-Cl → CH₃CH₂-C⁺(H)₂ + Cl⁻</p> <p>CH₃CH₂-C⁺(H)₂ + :NH₃ → CH₃CH₂-C(H)₂-NH₃⁺</p> <p>CH₃CH₂-C(H)₂-NH₃⁺ → CH₃CH₂-C(H)₂-NH₂ + H⁺</p> | |
|--|-----------------------------------------------------------------------------------------------------------------------------------------------------------------------------------------------------------------------------------------------------------------------------------------------------------------------------------------------------------------------------------------------------------------------|---------------------------------------------------------------------------------------------------------------------------------------------------------------------------------------------------------------------------------------------------------------------------------------------------------------------------------------------------------------------------------------------------------------------------------------------------------------------------------------------------------------------------------------------------------------------------------------------------|--|

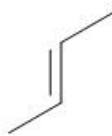
Q7.

| Question Number | Answer | | | Additional Guidance | Mark |
|-----------------|------------------------------------------------------------------------------------------------|------------------------------------------------------------------------------------------------|------------------------------------------------------------------------------------------------|--------------------------------------------------------------------------------------------------------------------------------------------------------------------------------------------------------------------------------------------------------------------------------------------------------------------------------------------------------------------------------------------------------------------------------------------------------------------------------------------------------------------------------|------|
| |  <p>(1)</p> |  <p>(1)</p> |  <p>(1)</p> | <p>Accept formulae in any order</p> <p>Award 2 if 3 correct displayed/structural formulae given</p> <p>Award 1 if 2 correct displayed/structural formulae given</p> <p>If more than 3 skeletal formulae drawn then deduct one mark for each additional formula</p> <p>2-methylpropene negates a correct formula only if four formulae given</p> <p>View any formulae given with skeletal formula as working and ignore</p> <p>Ignore names even if incorrect</p> <p>Penalise any other alkenes such as pentenes, once only</p> | (3) |

Edexcel Chemistry A-level - Halogenoalkanes

Q8.

| Question Number | Acceptable Answers | Additional Guidance | Mark |
|-----------------|----------------------------------------------------------------------------------------------------------------------------------------------------------------------------------------------------------------------------------------------------------------------------------------------------------------------------------------------------------------------------------------------------------------------------------------------------------------------------------------------------------------------------------------------------------------------------------------------------------------------------------------------------------------------------------------------------------------------------------------------------------------------------------------|--------------------------------------------------------------------------------------------------------------------------------------------------------------------------------------------------------------------------------------------------------------------------------------------------------------------------------------------------------------------------------------------------------------------------------------------------------------------------------------------------------------------------------------------------------------------------------------------------------------------------------------------------------------------------------------------------------------------------------------------------------------------------------------------------------------------------------------------------------------------------------------------------------------------------------------------------------------------------------------------------------------------------------------------------------------------------------------------------------------------------------------------------------------------------|------------|
| | <p>A synthetic pathway that includes:</p> <p>Conversion to alcohol</p> <ul style="list-style-type: none"> (aqueous ethanolic) potassium / sodium hydroxide (1) name or structure of propan-1-ol (1) <p>EITHER ROUTE 1</p> <p>Conversion to carboxylic acid</p> <ul style="list-style-type: none"> (oxidise some of the propan-1-ol using) potassium dichromate((VI)) and (dilute) sulfuric acid (1) name or structure of propanoic acid (1) <p>Formation of ester</p> <ul style="list-style-type: none"> react propan-1-ol and propanoic acid together and using (concentrated) sulfuric acid (catalyst) (1) <p>PTO for ROUTE 2</p> | <p>Allow names or formulae for reagents but if both are given, both must be correct Allow correct species in unbalanced equations Allow any combination of structural, displayed or skeletal formulae for the intermediates Penalise missing H once only Ignore conditions e.g. heat / reflux</p> <p>Allow hydroxide ions / OH⁻ Ignore concentration Do not award just ethanol / ethanolic</p> <p>Stand alone mark e.g. CH₃CH₂CH₂OH Allow propanol if correct structure shown somewhere</p> <p>Allow acidified potassium dichromate((VI)) / Cr₂O₇²⁻ and H⁺ Allow acidified manganate((VII)) Ignore concentration of acid / formation of aldehyde Do not award hydrochloric acid / HCl</p> <p>Stand alone mark e.g. CH₃CH₂COOH</p> <p>Stand alone mark for C₃ compounds Allow (concentrated hydrochloric) acid / H⁺ / H₃O⁺ instead of sulfuric acid Ignore concentration of acid</p> <p>Ignore incorrect structure of ester e.g. with H or O missing</p> | (5) |

Edexcel Chemistry A-level - Halogenoalkanes

| | | | |
|--|---------------------------------------------------------------------------------------------------------------------------------------------------------------------------------------------------------------------------------------------------------------------------------------------------------------------------------------------------------------------------------------------------------------------------------------------------------------------------------------------------------------------------------------------------------------------|------------------------------------------------------------------------------------------------------------------------------------------------------------------------------------------------------------------------------------------------------------------------------------------------------------------------------------------------------------------------------------------------------------------------------------------------------------------------------------------|--|
| | <p>OR ROUTE 2</p> <p>Conversion to acyl chloride</p> <ul style="list-style-type: none"> • (oxidise some of the propan-1-ol using) potassium dichromate(VI) and (dilute) sulfuric acid <p>and</p> <p>add phosphorus(V) chloride to propanoic acid (1)</p> <ul style="list-style-type: none"> • name or structure of propanoyl chloride (1) <p>Formation of ester</p> <ul style="list-style-type: none"> • react propan-1-ol and propanoyl chloride together (1) | <p>Allow acidified potassium dichromate(VI) / $\text{Cr}_2\text{O}_7^{2-}$ and H^+</p> <p>Allow acidified manganate(VII)</p> <p>Ignore concentration of acid / formation of aldehyde</p> <p>Do not award hydrochloric acid / HCl</p> <p>Stand alone mark e.g. $\text{CH}_3\text{CH}_2\text{COCl}$</p> <p>Stand alone mark for C_3 compounds</p> <p>Ignore incorrect structure of ester e.g. with H or O missing</p> | |
|--|---------------------------------------------------------------------------------------------------------------------------------------------------------------------------------------------------------------------------------------------------------------------------------------------------------------------------------------------------------------------------------------------------------------------------------------------------------------------------------------------------------------------------------------------------------------------|------------------------------------------------------------------------------------------------------------------------------------------------------------------------------------------------------------------------------------------------------------------------------------------------------------------------------------------------------------------------------------------------------------------------------------------------------------------------------------------|--|

Q9.

| Question Number | Answer | Mark |
|-----------------|--------------------------------------------------------------------------------------------------------------------------------------------------------------------------------------------------------------------------------------------------------------------------------------------------------------------------------------------|------|
| | <p>The only correct answer is C (3)</p> <p><i>A is not correct because the reaction forms but-1-ene and cis- and trans-but-2-ene</i></p> <p><i>B is not correct because the reaction forms but-1-ene and cis- and trans-but-2-ene</i></p> <p><i>D is not correct because the reaction forms but-1-ene and cis- and trans-but-2-ene</i></p> | (1) |

Edexcel Chemistry A-level - Halogenoalkanes

Q10.

| Question Number | Acceptable Answer | Additional Guidance | Mark | | | | | | | | | | | | |
|----------------------------------------------------|--------------------------------------------------------------------------------------------------------------------------------------------------------------------------------------------------------------------------------------------------------------------------------------------------------------------------------------------------------------------------------------------------------------------------------------------------------------------------------------------------------------------------------------------------------------------------------------------------------------------------------------------------------------------------------------------------------------------------------------------------------------------------------------------------------------------------------------------------------------------------------------------------------------------------------------------------------------------------------------------------------------------------------------------------------------------------------------------------------------------------------------------------------------------------------------------------------------------------------|----------------------------------------------------|-------------------------------------------------------|---|---|-----|---|-----|---|---|---|---|---|-----------------------------------------------------------------------------------------------------------------------------------------------------------------------------------------------------------------------------------------------------------------------------------------------------------------------------------------------------------------------------------------------------------------------------------------------------------------------------------------------------------------------------------------------------------------------------------------------------------------|-----|
| | <p>This question assesses the student's ability to show a coherent and logically structured answer with linkages and fully sustained reasoning.</p> <p>Marks are awarded for indicative content and for how the answer is structured and shows lines of reasoning.</p> <p>The following table shows how the marks should be awarded for indicative content.</p> <table border="1" data-bbox="411 703 836 931"> <thead> <tr> <th data-bbox="411 703 624 801">Number of indicative marking points seen in answer</th> <th data-bbox="624 703 836 801">Number of marks awarded for indicative marking points</th> </tr> </thead> <tbody> <tr> <td data-bbox="411 801 624 831">6</td> <td data-bbox="624 801 836 831">4</td> </tr> <tr> <td data-bbox="411 831 624 860">5-4</td> <td data-bbox="624 831 836 860">3</td> </tr> <tr> <td data-bbox="411 860 624 889">3-2</td> <td data-bbox="624 860 836 889">2</td> </tr> <tr> <td data-bbox="411 889 624 918">1</td> <td data-bbox="624 889 836 918">1</td> </tr> <tr> <td data-bbox="411 918 624 947">0</td> <td data-bbox="624 918 836 947">0</td> </tr> </tbody> </table> <p>The following table shows how the marks should be awarded for structure and lines of reasoning</p> | Number of indicative marking points seen in answer | Number of marks awarded for indicative marking points | 6 | 4 | 5-4 | 3 | 3-2 | 2 | 1 | 1 | 0 | 0 | <p>Guidance on how the mark scheme should be applied: The mark for indicative content should be added to the mark for lines of reasoning. For example, a response with four indicative marking points that is partially structured with some linkages and lines of reasoning scores 4 marks (3 marks for indicative content and 1 mark for partial structure and some linkages and lines of reasoning). If there were no linkages between the points, then the same indicative marking points would yield an overall score of 3 marks (3 marks for indicative content and zero marks for linkages).</p> | (6) |
| Number of indicative marking points seen in answer | Number of marks awarded for indicative marking points | | | | | | | | | | | | | | |
| 6 | 4 | | | | | | | | | | | | | | |
| 5-4 | 3 | | | | | | | | | | | | | | |
| 3-2 | 2 | | | | | | | | | | | | | | |
| 1 | 1 | | | | | | | | | | | | | | |
| 0 | 0 | | | | | | | | | | | | | | |

Edexcel Chemistry A-level - Halogenoalkanes

| | | | |
|--|----------------------------------------------------------------------------------------------------------------------------------------------------------------------------------------------------------------------------------------------------------------------------------------------------------------------------------------------------|----------------------------------------------------------------------------------|----------------------------------------------------------------------------------------------------------------------------------------------------------------------------------------------------------------------------------------------------------------------------------------------------------------------------------------------------------------------------------------------------------------------------------------------------------------------|
| | | Number of marks awarded for structure of answer and sustained lines of reasoning | <p>In general it would be expected that 5 or 6 indicative points would get 2 reasoning marks, and 3 or 4 indicative points would get 1 mark for reasoning, and 0, 1 or 2 indicative points would score zero marks for reasoning.</p> <p>If there is any incorrect chemistry, deduct mark(s) from the reasoning. If no reasoning mark(s) awarded do not deduct mark(s). More than one indicative marking point may be made within the same comment or explanation</p> |
| | Answer shows a coherent logical structure with linkages and fully sustained lines of reasoning demonstrated throughout | 2 | |
| | Answer is partially structured with some linkages and lines of reasoning | 1 | |
| | Answer has no linkages between points and is unstructured | 0 | |
| | <p>Indicative content</p> <ul style="list-style-type: none"> (similarity)(both) are nucleophilic substitution (1) Hydrolysis mechanism for RCH₂X/primary is S_N2 via a transition state and R₃CX/tertiary is S_N1 via a carbocation/intermediate (1) | | <p>Words needed at least once provided S_N1 and S_N2 are given</p> |

Edexcel Chemistry A-level - Halogenoalkanes

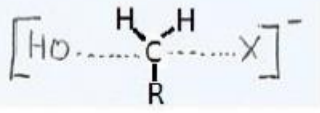
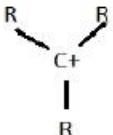
| | | | |
|--|-----------------------------------------------------------------------------------------------------------------------------------------------------------------------------------------------------------------------------------------------------------------------------------------------------------------------------------------------------------------------------------------------------------------------------------------------------------------------|-------------------------------------------------------------------------------------------------------------------------------------------------------------------------------------------------------------------------------------------------------------------------------------------------------------------------------------------------------------------------------------------------------------------------------------------------------------------------------------------------------------------------------------------------------------------|--|
| | <ul style="list-style-type: none"> • RCH_2X and OH^- in the RDS (1) • R_3CX only in the RDS (1) • (RCH_2X forms a transition state with OH^-) diagram, including dotted lines and charge (1) • (R_3CX forms a carbocation / intermediate) diagram, including charge (1) | <p>Allow "both/two species in the RDS"</p> <p>Allow correct rate equations for IP3 and IP4</p>  <p>Allow "-" either on the "OH" or the "X"</p> <p>Ignore point of attachment of OH</p> <p>Ignore dipoles within structure</p>  <p>Ignore shape</p> <p>Ignore references to comparative rates of reaction between 1° and 3° even if incorrect</p> <p>Ignore references to optical activity.</p> | |
|--|-----------------------------------------------------------------------------------------------------------------------------------------------------------------------------------------------------------------------------------------------------------------------------------------------------------------------------------------------------------------------------------------------------------------------------------------------------------------------|-------------------------------------------------------------------------------------------------------------------------------------------------------------------------------------------------------------------------------------------------------------------------------------------------------------------------------------------------------------------------------------------------------------------------------------------------------------------------------------------------------------------------------------------------------------------|--|

Q11.

| Question Number | Answer | Additional Guidance | Mark |
|-----------------|----------------------------------------------------------------------------------------------------------------------------------------------------------------------------------|--------------------------------------------------------------------------------------------------------------------------------------------------------------|------|
| | <p>An answer that makes reference to the following point:</p> <ul style="list-style-type: none"> • (hydroxide ions in ethanol would give an) elimination reaction | <p>Allow an alkene would form</p> <p>Ignore references to solubility in ethanol / ethanol is a (co-)solvent</p> <p>Ignore just 'causes another reaction'</p> | (1) |

Edexcel Chemistry A-level - Halogenoalkanes

Q12.

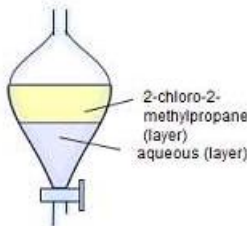
| Question Number | Acceptable Answers | Additional Guidance | Mark |
|-----------------|----------------------------------------------------------------------------------------------------------------------------------------------|---------------------------------------------------------------------------------------------------------------------------------------------------------------------------------------------------------------------------------------------------------------------------------------------------------------------------------------------------------------------------------------------------------------------------------------------------------------------------------------------------------------------------------|------|
| (a) | <ul style="list-style-type: none"> diagram of separating funnel (1) aqueous and organic layers labelled as shown (1) | <p>Mark independently</p> <p>Allow any shape separating funnel with tap at the bottom (does not need to be labelled), with a narrowing top or vertical sides but do not allow a burette</p> <p>Allow stopper/bung in separating funnel</p>  <p>Allow two layers shown and just one labelled correctly</p> <p>Allow organic layer/ product for top layer / hydrochloric acid for aqueous layer</p> <p>Do not allow 'reactant' for top layer</p> | (2) |

| Question Number | Acceptable Answers | Additional Guidance | Mark |
|-----------------|----------------------------------------------------------------------------------------------------------------------------------------------------------------------------------------------------------------------|---------------------------------------------------------------------------------------------------------------------------------------------------------------------------------------------------------------------------------------------------------|------|
| (b) | <ul style="list-style-type: none"> to react with/ neutralise any (unreacted/ excess hydrochloric) acid (1) to release the carbon dioxide produced or to relieve the build-up of pressure (1) | <p>Mark independently</p> <p>Allow to remove the (hydrochloric) acid</p> <p>Allow to neutralise the organic layer/ solution</p> <p>Allow to release gases</p> <p>Ignore just 'pressure builds up'</p> <p>Do not allow incorrect gases e.g. hydrogen</p> | (2) |

| Question Number | Answer | Mark |
|-----------------|--------------------|------|
| (c) | D (sodium sulfate) | (1) |

Edexcel Chemistry A-level - Halogenoalkanes

| Question Number | Acceptable Answers | Additional Guidance | Mark |
|-----------------|------------------------------------------------------------------------------------------------------------------------------------------------------------------------------------------------------------------------------------------------------------------------------------------------------------------------------------------------------------------------------------------------------------------------------|-----------------------------------------------------------------------------------------------------------------------------------------------------------------------------------------------------------------------------------------------------------------------------------------------------------------------------------------------------------------------------------------|------|
| (d)(i) | <p>A description that makes reference to the following points:</p> <ul style="list-style-type: none"> the (bulb of the) thermometer should be opposite the opening to the condenser (1) the water in and out of the condenser should be reversed (1) put a vent after the condenser or leave a gap between the condenser and the receiver or conical flask must be open (1) | <p>Allow these changes if shown on the diagram</p> <p>Allow thermometer should be higher up / above the liquid / should measure the temperature of the vapour / out of the mixture/liquid</p> <p>Allow water should enter the bottom (of the condenser)</p> <p>Ignore just 'vent' / the apparatus should not be completely sealed</p> <p>Ignore references to using a fume cupboard</p> | (3) |

| Question Number | Acceptable Answers | Additional Guidance | Mark |
|-----------------|-----------------------------------------------------------|------------------------------------------------------------------------------------------------------------|------|
| (d)(ii) | <ul style="list-style-type: none"> 50-52°C | <p>Allow any range between 49 and 53°C, <u>provided</u> it includes 51°C</p> <p>Do not allow just 51°C</p> | (1) |

Edexcel Chemistry A-level - Halogenoalkanes

| Question Number | Acceptable Answers | Additional Guidance | Mark |
|-----------------|--------------------------------------------------------------------------------------------------------------------------------------------------------------------------------------------------------------------------------------------------------------------------------------------------------------------------------------------------------------------------|---------------------------------------------------------------------------------------------------------------------------------------------------------------------------------------------------------------------------------------------------------------------------------------------------------------------------------------------------------------------------------------------------------------------------------------------------------------------------------------------------------------------------------------------------------------------------------------------------------------------------------------------------------------------------------------------------------------------------------------------------------------------------------------------------|------|
| (e) | <ul style="list-style-type: none"> calculation of moles of alcohol used (1) calculation of theoretical volume of 2-chloro-2-methylpropane made or calculation of actual moles of 2-chloro-2-methylpropane or calculation of actual mass of 2-chloro-2-methylpropane (1) calculation of percentage yield (1) | <p><u>Example of calculation</u> mass of alcohol used = $15.0 \times 0.79 = 11.85$ (g) moles of alcohol used = $11.85/74.0 = 0.16014$</p> <p>theoretical mass of chloro compound = $0.16014 \times 92.5 = 14.8125$ (g) theoretical volume = $14.8125/0.84 = 17.634$ (cm³) or actual moles of chloro compound = $6.9 \times 0.84 / 92.5 = 0.062659$ or actual mass of chloro compound = $0.062659 \times 92.5 = 5.796$ (g)</p> <p>% yield = $(6.9/17.634) \times 100 = 39.1\%$ or = $(0.062659/0.16014) \times 100 = 39.1\%$ or = $(5.796/14.8125) \times 100 = 39.1\%$</p> <p>TE on M1 and M2 Ignore SF except 1 SF</p> | (3) |

| | | | |
|--|--|-----------------------------------------|--|
| | | Correct answer without working scores 3 | |
|--|--|-----------------------------------------|--|

| Question Number | Acceptable Answers | Additional Guidance | Mark |
|-----------------|-------------------------------------------------------------------------------------------------------------------------------------------------------------------------|-----------------------------------------------------------------------------------------|------|
| (f) | <ul style="list-style-type: none"> curly arrow from C-O bond to O (1) curly arrow from lone pair on Cl⁻ to C⁺ (1) | <p>Do not allow single-headed arrows Do not allow additional, incorrect arrows</p> | (2) |

Edexcel Chemistry A-level - Halogenoalkanes

Q13.

| Question Number | Acceptable Answer | Additional Guidance | Mark |
|-----------------|----------------------------------------------------------------|----------------------------------------------------------------------------------------------------|------|
| (i) | <ul style="list-style-type: none"> substitution | Allow hydrolysis Ignore nucleophilic Do not award electrophilic Do not award displacement | (1) |

| Question Number | Answer | Mark |
|-----------------|-------------------------------------------------------------------------------------------------------------------------------------------------------------------------------------------------------------------------------------------------------------------------------------------------------------------------------------------------------------------------------------------|------|
| (ii) | <p>The only correct answer is D (phosphorus(V) chloride steamy fumes)</p> <p><i>A is not correct because this is the result with an acid</i></p> <p><i>B is not correct because this will identify the functional group in the starting 1-bromobutane</i></p> <p><i>C is not correct because this will identify the product of oxidation of an alcohol, not the alcohol itself</i></p> | (1) |

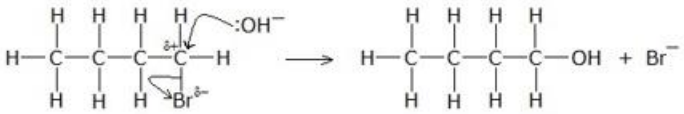
| Question Number | Acceptable Answer | Additional Guidance | Mark |
|-----------------|----------------------------------------------------------------------------------------------------------------------------------------------------------------------------------------------------------------------------------------------------|-------------------------------------------------------------------------------------------------------------------------------------------------------------------------------------------------------------------------------------------------------------------------------------------------------------------------------------------------------------------------------------------------------------------------------------------------------------------------------------------------|------|
| (iii) | <ul style="list-style-type: none"> curly arrow from lone pair of OH⁻ (1) curly arrow from C-Br bond to, or just beyond, Br (1) partial charges on C and Br and Br⁻ present as a product (1) |  <p>Arrows may be shown on a transition state in an S_N2 mechanism.</p> <p>Allow S_N1 mechanism. For S_N1 must also have correct carbocation to score M3.</p> <p>Ignore K⁺ on both sides or K⁺ on the left and KBr on the right Ignore connectivity of OH group in product</p> <p>Do not award HBr as product on the right</p> | (3) |

Edexcel Chemistry A-level - Halogenoalkanes

Q14.

| Question Number | Answer | Additional Guidance | Mark |
|-----------------|------------------------------------------------------------------------------------------------------------------------------------------------------------------------|---------------------------------------------------------------------------------------------------------------------------------------------------------------------------------------------------|------|
| (i) | <p>an answer that makes reference to the following points:</p> <ul style="list-style-type: none"> cream precipitate/precipitation (1) AgBr (1) | <p>Allow off-white / very pale yellow for cream Do not allow just yellow Allow ppt / ppte / solid / crystals for precipitate</p> <p>Ignore silver bromide Ignore state (if shown)</p> | (2) |

| Question Number | Answer | Mark |
|-----------------|--------------------------------------------------------------------------------------------------------------------------------------------------------------------------------------------------------------------------------------------------------------------------------------------------------------------------------------------|------|
| (ii) | <p>The only correct answer is C (Z, Y, X)</p> <p><i>A is not correct because hydrolysis of primary halogenoalkane (X) is the slowest</i></p> <p><i>B is not correct because hydrolysis of primary halogenoalkane (X) is the slowest</i></p> <p><i>D is not correct because hydrolysis of primary halogenoalkane (X) is the slowest</i></p> | (1) |

Q15.

| Question Number | Answer | Mark |
|-----------------|--------------------------------------------------------------------------------------------------------------------------------------------------------------------------------------------------------------------------------------------------------------------------------------------------|------|
| (i) | <p>The only correct answer is C (potassium cyanide)</p> <p><i>A is not correct because ammonia produces an amine</i></p> <p><i>B is not correct because there is no reaction with nitric acid</i></p> <p><i>D is not correct because silver nitrate makes silver chloride and an alcohol</i></p> | (1) |

Edexcel Chemistry A-level - Halogenoalkanes

| Question Number | Acceptable Answer | Additional Guidance | Mark |
|-----------------|-------------------------------------------------------------------------------------------------------------------------------------------------------------------------------------------------------------------------------------------------------------------------|-----------------------------------------------------------------------------------------------------------------------------------------------------------------------------------------------------------------------------------------------------|------|
| (ii) | <p>An answer that makes reference to the following points:</p> <ul style="list-style-type: none"> (Structural isomers are compounds with the same molecular formula / C_4H_7N (1) but different structural / displayed formula (1) | <p>Do not award just 'formula' or just 'general formula'</p> <p>Ignore similar instead of same</p> <p>Allow different order or arrangement of atoms</p> <p>Ignore examples of isomers</p> <p>Do not award just 'different arrangement in space'</p> | (2) |

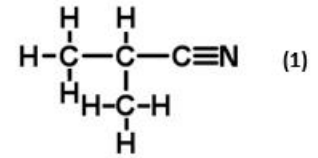
| Question Number | Acceptable Answer | Additional Guidance | Mark |
|-----------------|-----------------------------------------------------------------------------------------------------------------------------------------------------------------------------------------------------------------------------------------------------------------------------------------------------------------------------------------------------------------------------------------------------|---------------------------------------------------------------------------------------------------------------------------------------------------------------------------------------------------------------------------------------------------------------------------------------------------------------------|------|
| (iii) | <p>  $\begin{array}{c} \text{H} \quad \text{H} \\ \quad \\ \text{H}-\text{C}-\text{C}-\text{C}\equiv\text{N} \\ \quad \\ \text{H} \quad \text{H}-\text{C}-\text{H} \\ \\ \text{H} \end{array} \quad (1)$ (2-)methyl(-1-)propan(e)nitriple </p> | <p>All bonds must be shown</p> <p>Allow (2-)methylpropane(-1-)nitriple Do not award 2-cyanopropane</p> <p>M2 dependent on M1 or very near miss (such as correct structure not showing all bonds, or correct structure with H atoms not shown, or correct structure with nitrile with single or double bond)</p> | (2) |

Edexcel Chemistry A-level - Halogenoalkanes

Q16.

| Question Number | Answer | Additional Guidance | Mark |
|-----------------|----------------------------------------------------------------------------------------------------------------------------------------------------------------------------------------------------------------------------------------------------------------|------------------------------------------------------------------------------------------------------------------------------------------------------------------------------------------------------------------------------------------------------------------------------------------------------------------------------------------------------------|------|
| | <p>An explanation that makes reference to the following points:</p> <ul style="list-style-type: none"> reactivity increases down Group (7) (1) because (C–X) bond enthalpy decreases / because (C–X) bond gets weaker down Group 7 (1) | <p>Accept reverse argument</p> <p>References to halogen reactivity scores (0)</p> <p>Do not award references to ions/halides</p> <p>Do not award explanation in terms of just electronegativity or C–X dipoles</p> <p>Ignore references to atom size, shielding etc and references to intermolecular forces</p> <p>No TE on incorrect reactivity trend</p> | (2) |

Q17.

| Question Number | Answer | Additional Guidance | Mark |
|-----------------|------------------------------------------------------------------------------------------------------------------------------------------------------------------------------------------|------------------------------------------------------------------------------------------------------------------------------------------------|------|
| (i) | <p>An answer that makes reference to the following points:</p> <ul style="list-style-type: none"> potassium hydroxide / KOH (1) alcohol / ethanol and reflux (1) | <p>Mark independently</p> <p>Allow sodium hydroxide / NaOH</p> <p>Allow just 'heat' in place of reflux</p> <p>Do not award aqueous ethanol</p> | (2) |

Edexcel Chemistry A-level - Halogenoalkanes

| Question Number | Answer | Additional Guidance | Mark |
|-----------------|---------------------------------------------------------------|--------------------------------------------------------------------------------------------------------------------------------------------------------------------------------------------------------------------------------------------------------------------------------------------------------------------------------------------------------------------------------------------------------------------------------|------|
| (ii) | <ul style="list-style-type: none"> repeat unit | <p><u>Example of repeat unit</u></p> $ \begin{array}{c} \text{H} \\ \\ \text{H}-\text{C}-\text{H} \\ \quad \\ \left[\text{C}-\text{C} \right] \\ \quad \\ \text{H}-\text{C}-\text{H} \\ \\ \text{H} \end{array} $ <p>Allow non-displayed methyl groups (-CH₃) Ignore connectivity of the methyl group Allow n outside brackets</p> <p>Ignore missing brackets / round brackets</p> | (1) |

| Question Number | Answer | Additional Guidance | Mark |
|-----------------|------------------------------------------------------------------------------------------------------------------------------------------------------------------------------------------------------------------------------------------------------------------------------------------------------------------------------------------------------------------------------------------------------------------------------|----------------------------------------------------------------------------------------------------------------------------------------|------|
| (iii) | <ul style="list-style-type: none"> curly arrow from double bond to H of HBr and correct structure of 2-methylpropene (1) curly arrow from H-Br bond to Br atom and correct dipole on HBr molecule (1) intermediate with + on correct Carbon and Br⁻ (1) lone pair on Br⁻ and curly arrow from lone pair to C⁺ (1) | <p><u>Example of mechanism</u></p> <p>incorrect structure of 2-methylpropene loses M1 only + on incorrect carbon loses M3 only</p> | (4) |

Edexcel Chemistry A-level - Halogenoalkanes

Q18.

| Question Number | Acceptable Answer | Additional guidance | Mark |
|-----------------|--------------------------------------------------------------------------------------------------------------------------------------------------------------------------------------------------------------------------------------------------------------------------------------------------------------------------|----------------------------------------------------------------------------------------------------------------------------------------------------------------------------------------------------------------------|------------|
| | <p>An explanation that makes reference to the following</p> <ul style="list-style-type: none">the reaction rate is in the order 1-chlorobutane < 1-bromobutane < 1-iodobutane (1)because the C-Cl bond is stronger than the C-Br bond which is stronger than the C-I bond (1) | <p>Accept reverse arguments Incorrect trend scores (0)</p> <p>Allow 'the C-Cl bond is the strongest' Ignore any reasoning given Do not award if reference is made to the bonding of the halide (ion)</p> | (2) |

Q19.

| Question Number | Answer | Additional Guidance | Mark |
|-----------------|---------------------------------------------------------------------------------------------------------------------------------------------------------------------------------------------------------------------------------------------------------------------------------------------------------------------------------------------------------|---------------------------------------------------------------------------------------------------------------------------------------------------------------------------------------------------------------------------------------------------------------------------------------------------------------------------------------------------------------------------------------------------------------------------------------------------------------------------------------------------------------------------------------------------------------------------------------------------------------------------------------------------------------------------------------------------------------------------------------------------------------------------------------------------------------------------------------------------------------------------------------------------------------------------------------------------------------------------------------|------|
| (i) | <ul style="list-style-type: none"> dipole on C–Br bond and curly arrow from C-Br bond to Br or just beyond (1) curly arrow from lone pair on oxygen of hydroxide ion to carbon bonded to Br (1) formula of transition state with correct charge, partial bonding (1) correct final products (1) |  <p>Dipole and curly arrow may be shown on transition state</p> <p>Allow curly arrow to C⁺ of carbocation</p> <p>Do not award if carbocation formed as intermediate Square brackets are not essential Allow charge on Br or OH of transition state Allow longer bonds for partial bonding Ignore geometry of transition state</p> <p>Allow NaBr product if mechanism starts with NaOH</p> <p>Only penalise horizontal bond from the H of OH to C in the product e.g. OH–CH₂CH₃</p> <p>Use of incorrect halogenoalkane loses this mark</p> <p>One mark max deducted for omission of charge on ions, including transition state</p> <p>S_N1 mechanism can score M1, M2 and M4 but not M3. M2 can be awarded for curly arrow from the lone pair on the oxygen of the hydroxide ion to the C⁺ of the carbocation intermediate</p> | (4) |

Edexcel Chemistry A-level - Halogenoalkanes

| Question Number | Answer | Additional Guidance | Mark |
|-----------------|--------------------------------------------------------------------------------------------------------------------------------------------------------------------------------------------------------------------------------------------------------------------|----------------------------------------------------------------------------------------------------------------------------------------------------------------------------------------------------------------------------------------------------------------------------------------------------------------------------------------------------------------------------------------------------------------------------------------------------------------------------------------------------------------------------------------------------------------------------------------------------------------------------------------------------------------------------------------------------------------------------------------------------------------------|------------|
| (ii) | <p>Reagents: nitric acid / HNO₃ and silver nitrate (solution) / AgNO₃ (1)</p> <p>(Result) cream/off-white precipitate (1)</p> | <p>Use of hydrochloric acid/HCl OR sulfuric acid/H₂SO₄ scores (0) Do not award acidified silver nitrate If name and formula given then both must be correct</p> <p>Allow (very) pale yellow Do not award just white or just yellow Ignore subsequent additions of ammonia even if incorrect Result mark dependent on reagents mark or 'near miss' such as omitting to add nitric acid, using ethanolic silver nitrate, incorrect formulae</p> | (2) |

Q20.

| Question Number | Answer | Additional Guidance | Mark |
|-----------------|---------------------------------------------------------------------------------------------------------------------------------------------------------------|----------------------------------------------|------------|
| (i) | $ \begin{array}{c} \text{H} \quad \text{H} \\ \quad \\ \text{H}-\text{C}-\text{C}-\text{H} \\ \quad \\ \text{H} \quad \text{Cl} \end{array} $ | Do not award skeletal or structural formulae | (1) |

Edexcel Chemistry A-level - Halogenoalkanes

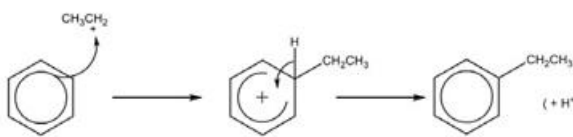
| Question Number | Answer | Additional Guidance | Mark |
|-----------------|----------------------------------------------------------------------------------------------------------------------------------------------------------------------------------------------------------------------------------------------------------------------------------------------------------------------------------------------------------------------------------------------------|-----------------------------------------------------------------------------------------------------------------------------------------------------------------------------------------------------------------------------------------------------------------------------------------------------------------------------------------------------------------------------------------------------------------------------------------------------------------------------------------------------------------------------------------------------------------------------------------------------------------------------------------------------------------------------------------------------------------------------------------------------------------------------------------------------------------------------------------------------------------------------------------------------------------------------------------------------------------------------------------------------------|------|
| (ii) | <ul style="list-style-type: none"> • M1 equation to show formation of electrophile (1) • M2 curly arrow from anywhere on the central ring to positive carbon (1) • M3 structure of intermediate (1) • M4 curly arrow from C-H bond to reform the ring (1) • M5 equation showing regeneration of catalyst (1) | <p><u>Example of mechanism</u> Penalise incorrect halogenoalkane in (a)(i) only</p> $\text{CH}_3\text{CH}_2\text{Cl} + \text{AlCl}_3 \rightarrow \text{CH}_3\text{CH}_2^+ + \text{AlCl}_4^-$ <p>Ignore any curly arrows given in the equation</p> <p>Allow curly arrow from anywhere within the hexagon Do not award if curly arrow to CH₃ carbon in CH₃CH₂⁺ Do not award if curly arrow to C₂H₅⁺</p> <p>Horseshoe facing the tetrahedral carbon and covering at least three carbon atoms Some part of the positive charge in the horseshoe</p> <p>Do not award dotted lines unless clearly part of a 3D structure</p> <p>$\text{AlCl}_4^- + \text{H}^+ \rightarrow \text{AlCl}_3 + \text{HCl}$ Ignore regeneration step if part of the mechanism</p> <p>Mechanism</p>  <p>Allow TE from (a)(i)</p> | (5) |

Edexcel Chemistry A-level - Halogenoalkanes

| Question Number | Answer | Additional Guidance | Mark |
|-----------------|--------------------------------------------------------------------------------------------------------------------------------------------------------------------------------------------------------------------------------------------------------------------------------------------------------------------------------------------------------------------------------------------------------------------------------------------------------------------------------------|--------------------------------------------------------------------------------------------------------------------------------------------------------------------------------------------------------------------------------------------------------------------------------------------------------------|------|
| (iii) | <p>An explanation that makes reference to the following points:</p> <p>Phenol is likely to be more reactive because</p> <ul style="list-style-type: none"> • M1 lone pair on oxygen (atom of –OH group) delocalises / is incorporated into the (benzene) ring / donated to the ring (1) • M2 which increases the electron density (of the ring) (1) • M3 making the ring / phenol more susceptible to electrophilic attack (1) | <p>Do not award M2 if mention of “charge density” / “electronegativity” Ignore references to “the ring becomes more negative”</p> <p>Award “making the ring more nucleophilic” / “making the ring more susceptible to attack by a positive ion”</p> <p>Ignore references to “activation of the ring”</p> | (3) |

Q21.

| Question Number | Answer | Additional Guidance | Mark |
|-----------------|----------------------------------------------------------------------------------------------------------------------------------------------------------------------------------------------------------------------------|--------------------------------------------------------------------------------------------------------------------------------------------------------------------------------------------------------------------------------------------------------------------------------------------|------|
| (a)(i) | <ul style="list-style-type: none"> • ethanol is added to dissolve both the halogenoalkane and water / to allow the halogenoalkane and water to mix / to form a homogeneous mixture / to act as a co-solvent | <p>Allow silver nitrate as an alternative to water Allow so the halogenoalkane becomes soluble in water Do not award descriptions of dissolving one of the two reactants but not the other Do not award ethanol is a solvent Do not award to allow the halogens to mix</p> | (1) |

Edexcel Chemistry A-level - Halogenoalkanes

| Question Number | Answer | Additional Guidance | Mark |
|-----------------|---------------------------------------------------------------------------------------------------------------------------------------------------------------------------------------------------------|--------------------------------------------------------------------------------------------------------------------------------------------------------------------|------|
| (a)(ii) | <ul style="list-style-type: none"> so they are the same temperature <p>OR</p> <ul style="list-style-type: none"> so only the type of halogen affects the rate of reaction | <p>(1)</p> <p>Allow to ensure the temperature remains constant Allow heat for temperature Ignore constant conditions Ignore to make it a fair test</p> | (1) |

| Question Number | Answer | Additional Guidance | Mark |
|-----------------|--------------------------------------------------------------------------------------------------|---------------------------------------------------------------------------------------------------------------------------------------------------------------------------------------------|------|
| (a)(iii) | <ul style="list-style-type: none"> To ensure the reactants are mixed (thoroughly) | <p>(1)</p> <p>Allow so the mixture is homogeneous Ignore so the particles collide Ignore to form the precipitate Do not award references to kinetic energy of the molecules</p> | (1) |

| Question Number | Answer | Additional Guidance | Mark |
|-----------------|------------------------------------------------------------------------------------------------------------------------------------------------------------------------|--------------------------------------------------------------------------------------------------------------------------------------------------------------------------------------------------|------|
| (b)(i) | <ul style="list-style-type: none"> chloride white precipitate and bromide cream precipitate and iodide yellow precipitate | <p>(1)</p> <p>Penalise the incorrect use of chlorine, bromine and iodine once only in 7(b)(i) and 7(b)(ii)</p> <p>Accept Off-white or (very) pale yellow</p> <p>Do not award pale yellow</p> | (1) |

Edexcel Chemistry A-level - Halogenoalkanes

| Question Number | Answer | Additional Guidance | Mark |
|-----------------|-----------------------------------------------------------------------------------------------------------------------------------------------------------------------------------------------------------------------------------------------------------------------------------------------------------------------------------------------------------------------------------------------------------------------------------------------------------|------------------------------------------------------|------|
| (b)(ii) | <ul style="list-style-type: none"> • use of dilute and concentrated ammonia solution / aqueous ammonia • silver chloride / precipitate from 1-chlorobutane is soluble in dilute (and concentrated ammonia) and silver bromide / precipitate for 1-bromobutane is soluble only in concentrated ammonia and silver iodide / precipitate from 1-iodobutane is insoluble in both dilute and concentrated ammonia | <p>(1)</p> <p>(1)</p> <p>Allow partially soluble</p> | (2) |

| Question Number | Acceptable Answer | Additional Guidance | Mark | | | | | | | | | | | | |
|----------------------------------------------------|--------------------------------------------------------------------------------------------------------------------------------------------------------------------------------------------------------------------------------------------------------------------------------------------------------------------------------------------------------------------------------------------------------------------------------------------------------------------------------------------------------------------------------------------------------------------------------------------------------------------------------------------------------------------------------------------------------------------------------------------------------------------------|----------------------------------------------------|-------------------------------------------------------|---|---|-----|---|-----|---|---|---|---|---|-------------------------------------------------------------------------------------------------------------------------------------------------------------------------------------------------------------------------------------------------------------------------------------------------------------------------------------------------------------------------------------------------------------------------------------------------------------------------------------------------------------------------------------------------------------------------------------------------------------------------|---|
| (c) | <p>This question assesses a student's ability to show a coherent and logically structured answer with linkages and fully-sustained reasoning.</p> <p>Marks are awarded for indicative content and for how the answer is structured and shows lines of reasoning.</p> <p>The following table shows how the marks should be awarded for indicative content.</p> <table border="1" data-bbox="389 1529 833 1794"> <thead> <tr> <th>Number of indicative marking points seen in answer</th> <th>Number of marks awarded for indicative marking points</th> </tr> </thead> <tbody> <tr> <td>6</td> <td>4</td> </tr> <tr> <td>5-4</td> <td>3</td> </tr> <tr> <td>3-2</td> <td>2</td> </tr> <tr> <td>1</td> <td>1</td> </tr> <tr> <td>0</td> <td>0</td> </tr> </tbody> </table> | Number of indicative marking points seen in answer | Number of marks awarded for indicative marking points | 6 | 4 | 5-4 | 3 | 3-2 | 2 | 1 | 1 | 0 | 0 | <p>Guidance on how the mark scheme should be applied:</p> <p>The mark for indicative content should be added to the mark for lines of reasoning.</p> <p>For example, an answer with five indicative marking points, which is partially structured with some linkages and lines of reasoning, scores 4 marks (3 marks for indicative content and 1 mark for partial structure and some linkages and lines of reasoning).</p> <p>If there are no linkages between points, the same five indicative marking points would yield an overall score of 3 marks (3 marks for indicative content and no marks for linkages).</p> | 6 |
| Number of indicative marking points seen in answer | Number of marks awarded for indicative marking points | | | | | | | | | | | | | | |
| 6 | 4 | | | | | | | | | | | | | | |
| 5-4 | 3 | | | | | | | | | | | | | | |
| 3-2 | 2 | | | | | | | | | | | | | | |
| 1 | 1 | | | | | | | | | | | | | | |
| 0 | 0 | | | | | | | | | | | | | | |

Edexcel Chemistry A-level - Halogenoalkanes

| | | |
|-----------------------------------------------------------------------------------------------------------------------------|---------------------------------------------------------------------------------|----------------------------------------------------------------------------------------------------------------------------------------------------------------------------------------------------------------------------------------------------------------------------------------------------------|
| The following table shows how the marks should be awarded for structure and lines of reasoning. | | <p>In general it would be expected that 5 or 6 indicative points would get 2 reasoning marks, and 3 or 4 indicative points would get 1 mark for reasoning, and 0, 1 or 2 indicative points would score zero marks for reasoning.</p> <p>Reasoning marks may be reduced for extra incorrect chemistry</p> |
| | Number of marks awarded for structure answer and sustained of line of reasoning | |
| Answer shows a coherent and logical structure with linkages and fully sustained lines of reasoning demonstrated throughout. | 2 | |
| Answer is partially structured with some linkages and lines of reasoning. | 1 | |
| Answer has no linkages between points and is unstructured. | 0 | |

| | |
|--------------------------------------------------------------------------------------------------------------------------------------------------------------------------------------------------------------------------------------------------------------------------------------------------------------------------------------------------------------------------------------------------------------------------------------------------------------------------------------------------------------------------------------------------------------------------------------------------------------------------------------------------------------|--------------------------------------------------------------------------------------------------------------------------------------------------------------------------------------------------------------------------------------------------------------------------------------------------|
| <p>Indicative content:</p> <ul style="list-style-type: none"> IP1 Use equal amounts / numbers of moles / volumes of either halogenoalkane or silver nitrate solution IP2 and IP3 Use isomeric primary, secondary and tertiary bromoalkanes e.g 1-bromobutane or 1-bromo-2-methylpropane and 2-bromobutane and 2-bromo-2-methylpropane IP4 Time how long it takes for a precipitate to form / observe the order in which the precipitates form IP5 Shorter the time the faster the rate IP6 Correct order of precipitation given / tertiary forms before secondary before primary | <p>Allow ethanol Do not award equal masses Ignore lack of ethanol</p> <p>Any two scores IP2 All 3 scores IP3 provided they are isomers Accept names or formulae but if both given they must both be correct</p> <p>$1 \div \text{time} = \text{rate of reaction}$</p> |
|--------------------------------------------------------------------------------------------------------------------------------------------------------------------------------------------------------------------------------------------------------------------------------------------------------------------------------------------------------------------------------------------------------------------------------------------------------------------------------------------------------------------------------------------------------------------------------------------------------------------------------------------------------------|--------------------------------------------------------------------------------------------------------------------------------------------------------------------------------------------------------------------------------------------------------------------------------------------------|

Edexcel Chemistry A-level - Halogenoalkanes

Q22.

| Question Number | Answer | Additional Guidance | Mark |
|-----------------|-----------------------------------------------------------------------------|----------------------------------------------------------------------------------------------------------|------|
| (i) | <ul style="list-style-type: none"> zero (order 0 / 0 (order) | Allow $x = 0$ / rate is proportional to $[\text{OH}^-]^0$ / rate = $k[\text{R-Br}][\text{OH}^-]^0$ | (1) |

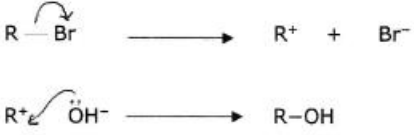
| Question Number | Answer | Additional Guidance | Mark |
|-----------------|---------------------------------------------------------------------------------------------------------------------------------------------------------------------------------------------------------------------------------------------------------------------------------------------|--------------------------------------------------------------------------------------------------------------------------------------------|------|
| (ii) | <ul style="list-style-type: none"> curly arrow from R-Br bond to, or just beyond, Br (1) R^+ and Br^- (1) lone pair on O of OH^- and curly arrow from lone pair to R^+ (1) | <p>Example of mechanism</p>  <p>Ignore dipole on RBr</p> | (3) |

Q23.

| Question Number | Answer | Additional Guidance | Mark |
|-----------------|----------------------------------------------------------------------------------------------------------------------------------------------------------------------------------------------------------------------------------------------------------------------------------------------------------------------------------------------------------------------------------------------------------------------------------------------------------------------------------------------------------------------------------------------|-----------------------------------------------------------------------------------------------------------------------------------------------------------------------------------------------------------------------------------------------------------------------------------------------------------------------------------------------------------------------------------------------------------------------|------|
| | <p>An explanation that makes reference to the following points:</p> <ul style="list-style-type: none"> a racemic mixture / racemate is formed or equal amounts / an equimolar mixture of both optical isomers forms (1) intermediate / carbocation is (trigonal) planar around the reaction site / C^+ / central carbon (1) (equal probability of) attack (by nucleophile / hydroxide ions) from either side / above and below / both sides / opposite sides (of the plane) (1) | <p>Allow enantiomers / D-L isomers / (+) and (-) isomers Allow the two isomers rotate the plane of plane-polarised light in opposite directions and cancel out Ignore just 'mixture is not optically active' / 'mixture does not rotate the plane of plane-polarised light'</p> <p>Allow the intermediate / carbocation is planar (around the reaction site)</p> <p>Do not award 'the molecule is planar'</p> | (3) |