

**Questions**

**Q1.**

The fluid mosaic model of cell membranes was first proposed in 1972.

The vacuoles in beetroot cells contain molecules of betalain, a red pigment.

Betalains are large polar molecules.

These molecules can leave beetroot cells if the vacuole membrane and the cell surface membrane are damaged.

Explain why betalain molecules cannot move through intact cell membranes.

**(3)**

.....

.....

.....

.....

.....

.....

.....

.....

.....

.....

**(Total for question = 3 marks)**

## Edexcel Biology A-level - Exchange of Substances

Q2.

In birds and mammals, gas exchange takes place between the blood in the capillaries and the air in the alveoli.

There are three layers between the blood and the air in the alveoli: the capillary wall, a layer of extracellular matrix and the alveolar wall. This is called the blood-gas barrier.

The electron micrographs show the blood-gas barriers for a chicken and a dog.

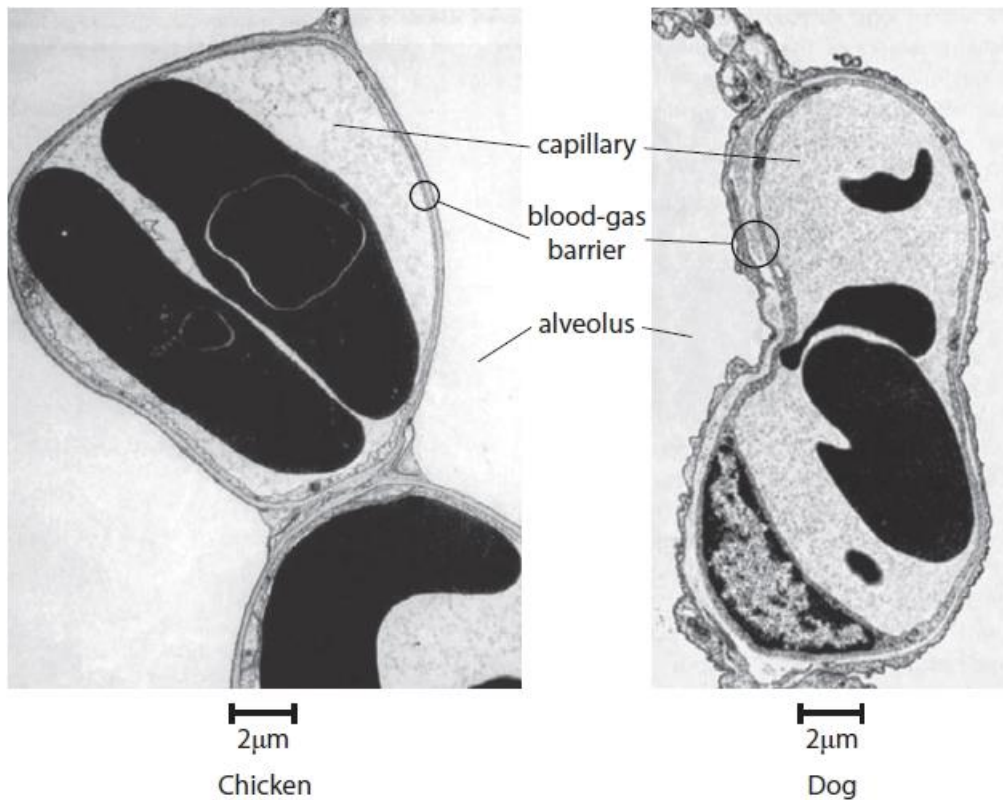

Explain how the blood-gas barrier of the chicken is adapted to give more efficient gas exchange than the blood-gas barrier of the dog.

(3)

.....

.....

.....

.....

.....

.....

.....

(Total for question = 3 marks)

## Edexcel Biology A-level - Exchange of Substances

### Q3.

The structure of the cell surface membrane can be explained using the fluid mosaic model.

This model suggests that there are a variety of different proteins and glycoproteins present in a phospholipid bilayer.

The drawing shows the cell surface membrane of a liver cell. The drawing has a magnification of  $5 \times 10^6$ .

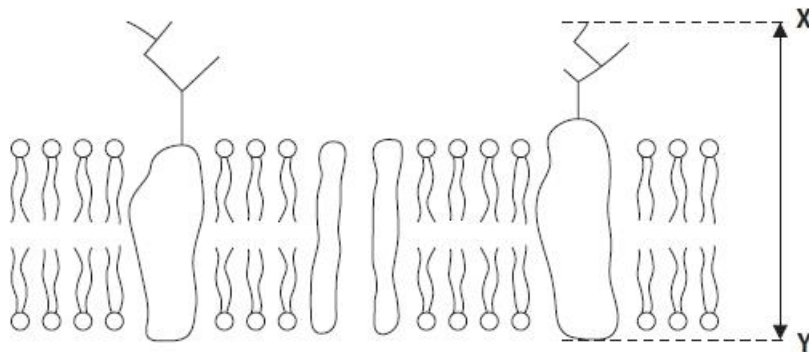

Calculate the actual length of the glycoprotein between points X and Y.  
Give your answer with an appropriate unit.

(2)

Answer .....

**(Total for question = 2 marks)**

## Edexcel Biology A-level - Exchange of Substances

Q4.

Answer the question with a cross in the box you think is correct . If you change your mind about an answer, put a line through the box  and then mark your new answer with a cross .

The fluid mosaic model of cell membranes was first proposed in 1972.

One piece of evidence that was used to support the idea of a phospholipid bilayer was the arrangement of phospholipid molecules on a surface between air and water.

(i) Complete the diagram to show the arrangement of four phospholipid molecules at this surface.



(2)

(ii) Which of the molecules found in cell membranes have hydrophilic regions?

- A** channel proteins only
- B** only phospholipids and channel proteins
- C** phospholipids, channel proteins and cholesterol
- D** phospholipids only

(1)

**(Total for question = 3 marks)**

## Edexcel Biology A-level - Exchange of Substances

**Q5.**

Diffusion and active transport are mechanisms by which molecules can enter cells.

Compare and contrast these two mechanisms.

**(3)**

.....

.....

.....

.....

.....

.....

.....

.....

.....

.....

.....

.....

**(Total for question = 3 marks)**

## Edexcel Biology A-level - Exchange of Substances

**Q6.**

Endocytosis and exocytosis are processes that move large molecules into a cell or out of a cell.

Compare and contrast the processes of endocytosis and exocytosis.

**(3)**

.....

.....

.....

.....

.....

.....

.....

.....

.....

.....

**(Total for question = 3 marks)**

## Edexcel Biology A-level - Exchange of Substances

Q7.

The cell surface membrane controls the movement of substances into the cell.

The concentrations of two substances inside the cytoplasm of a cell and in the fluid surrounding the cell were investigated.

The table shows the concentrations of these two substances.

Substance	Description of substance	Concentration in cytoplasm / $\text{mmol dm}^{-3}$	Concentration in fluid surrounding the cell / $\text{mmol dm}^{-3}$
sodium	small ion	140.0	9.0
glucose	large polar molecule	0.1	14.9

(i) Explain why ATP is required for the movement of sodium ions into the cell.

(2)

.....

.....

.....

.....

.....

.....

(ii) Describe how glucose molecules move into the cell.

(2)

.....

.....

.....

.....

.....

.....

**(Total for question = 4 marks)**

## Edexcel Biology A-level - Exchange of Substances

Q8.

The internal conditions within the body are maintained by homeostatic mechanisms. The regulation of blood glucose involves homeostatic mechanisms.

The diagram shows part of the sequence of events when there is an increase in blood glucose levels.

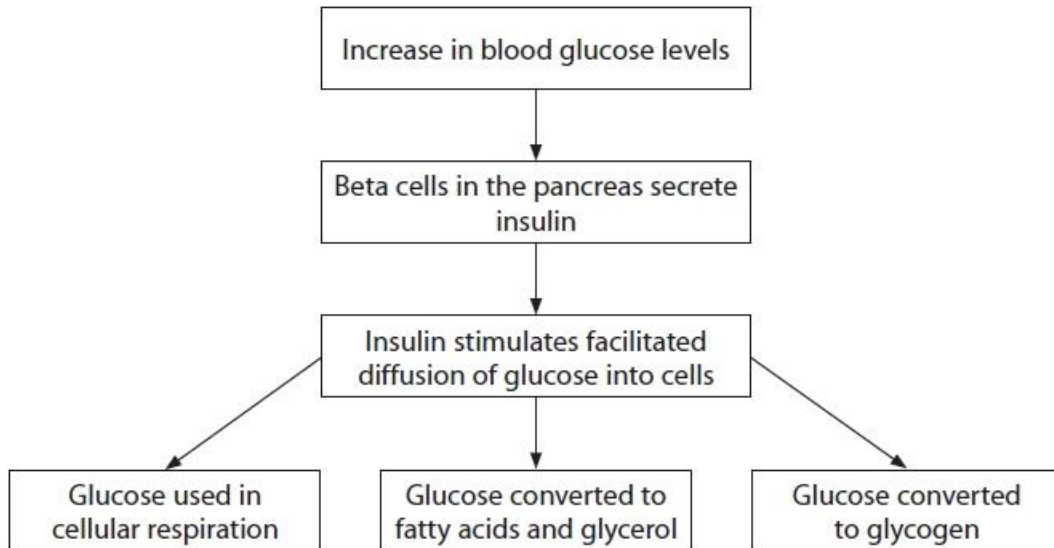

(i) Describe how glucose moves into cells by facilitated diffusion.

(2)

.....

.....

.....

.....

.....

.....

(ii) Explain how the structure of glycogen allows it to be an energy store.

(3)

.....

.....

.....

.....

.....

.....

.....

.....

(Total for question = 5 marks)



## Edexcel Biology A-level - Exchange of Substances

**Q9.**

Glycoproteins and phospholipids are molecules found in the cell surface membrane.

(i) Give **one** function of the glycoproteins found in the cell surface membrane.

(1)

.....  
.....

(ii) A cell surface membrane is partially permeable.

The phospholipid bilayer is important in controlling the movement of molecules through the membrane.

Explain how the structure of a phospholipid molecule contributes to the partial permeability of a cell surface membrane.

(3)

.....  
.....  
.....  
.....  
.....  
.....  
.....  
.....  
.....  
.....  
.....

**(Total for question = 4 marks)**

## Edexcel Biology A-level - Exchange of Substances

**Q10.**

A baby was born with an abnormal heart. The diagram shows the heart of this baby. There is a hole in the septum between the two ventricles.

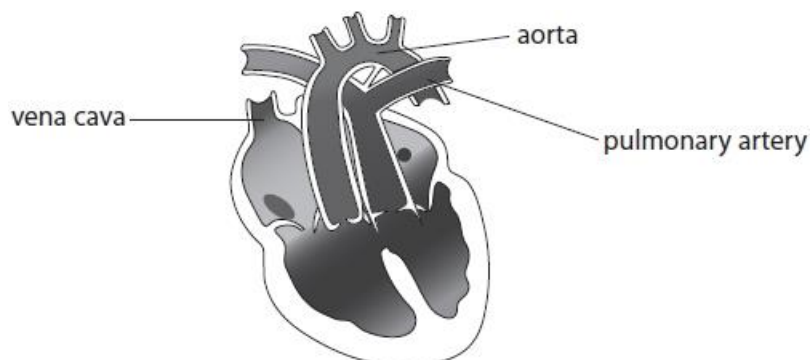

Oxygen diffuses between the alveoli of the lungs and the blood.

Fick's Law shows how three factors affect the rate of diffusion:

$$\text{Rate of diffusion} = \frac{\text{surface area} \times \text{concentration difference}}{\text{diffusion distance}}$$

The diagram and the table give information about the oxygen concentration in the alveoli and in the blood.

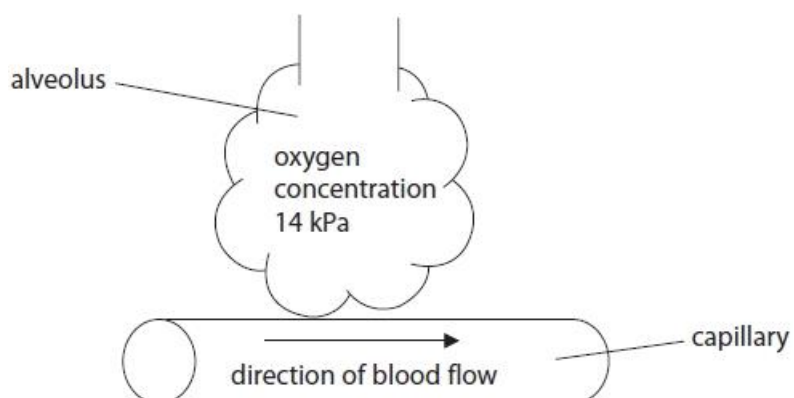

Heart	Oxygen concentration / kPa	
	Blood entering the lungs	Blood leaving the lungs
Normal	5	13
With hole in the septum between the ventricles	8	10

## Edexcel Biology A-level - Exchange of Substances

\* Assess the effect of this heart defect on the rate of oxygen diffusion between the alveoli and the blood.

(6)

.....

.....

.....

.....

.....

.....

.....

.....

.....

.....

.....

.....

.....

.....

.....

.....

.....

.....

.....

.....

.....

.....

.....

.....

.....

.....

.....

**(Total for question = 6 marks)**

## Edexcel Biology A-level - Exchange of Substances

Q11.

Emphysema is a condition that causes changes to the tissues in the lungs.

In an investigation, the surface area for gas exchange and the volume of the lungs of three groups of individuals were determined. The results are shown in the table.

Measurement	Individuals without emphysema	Individuals with mild emphysema	Individuals with severe emphysema
Mean surface area for gas exchange / m <sup>2</sup>	118 ± 11	97 ± 8	30 ± 5
Mean total lung volume / cm <sup>3</sup>	4772 ± 223	6232 ± 410	6725 ± 384
Mean surface area for gas exchange : volume ratio	247.3 : 1		44.6 : 1

(i) Calculate the mean surface area for gas exchange : volume ratio for individuals with mild emphysema.

(2)

Answer .....

(ii) There appears to be a difference in the lung volume of individuals with mild emphysema and those with severe emphysema.

Which of the following would be a relevant statistical test to determine whether this difference is significant?

(1)

- A chi-squared
- B correlation coefficient
- C standard deviation
- D Student's t-test

## Edexcel Biology A-level - Exchange of Substances

(iii) Give reasons for the variation in the lung volumes of healthy individuals.

(2)

.....

.....

.....

.....

.....

.....

.....

(iv) Give a reason for calculating the surface area for gas exchange to volume ratio in this investigation.

(1)

.....

.....

.....

.....

**(Total for question = 6 marks)**

**Edexcel Biology A-level - Exchange of Substances**

**Q12.**

Blood type is an example of inherited variation.

Blood types A, B, AB and O are determined by a single gene.

Blood types are due to the presence or absence of antigens on the cell surface membranes of red blood cells.

These antigens are glycoproteins.

Antigens on the cell membranes of microbes can stimulate endocytosis and exocytosis in white blood cells.

These processes are involved in transport through a cell surface membrane.

Give two differences between endocytosis and exocytosis.

(2)

.....

.....

.....

.....

.....

.....

.....

.....

.....

**(Total for question = 2 marks)**

## Edexcel Biology A-level - Exchange of Substances

**Q13.**

All cells have a cell surface membrane.

Explain how phospholipids form a cell surface membrane.

**(3)**

.....

.....

.....

.....

.....

.....

.....

.....

.....

.....

**(Total for question = 3 marks)**

## Edexcel Biology A-level - Exchange of Substances

### Q14.

Emphysema is a condition that causes changes to the tissues in the lungs.

In an investigation, the surface area for gas exchange and the volume of the lungs of three groups of individuals were determined. The results are shown in the table.

Measurement	Individuals without emphysema	Individuals with mild emphysema	Individuals with severe emphysema
Mean surface area for gas exchange / m <sup>2</sup>	118 ± 11	97 ± 8	30 ± 5
Mean total lung volume / cm <sup>3</sup>	4772 ± 223	6232 ± 410	6725 ± 384
Mean surface area for gas exchange : volume ratio	247.3 : 1		44.6 : 1

Explain why individuals with severe emphysema will tire more easily than healthy individuals.

(3)

.....

.....

.....

.....

.....

.....

.....

.....

.....

.....

.....

.....

.....

.....

.....

.....

.....

.....

.....

.....

.....

.....

(Total for question = 3 marks)



## Edexcel Biology A-level - Exchange of Substances

**Q15.**

Explain why the phospholipids are arranged in two layers in a cell surface membrane.

**(3)**

.....

.....

.....

.....

.....

.....

.....

.....

.....

.....

.....

**(Total for question = 3 marks)**

## Edexcel Biology A-level - Exchange of Substances

### Q16.

Emphysema is a condition that causes changes to the tissues in the lungs.

In an investigation, the surface area for gas exchange and the volume of the lungs of three groups of individuals were determined. The results are shown in the table.

Measurement	Individuals without emphysema	Individuals with mild emphysema	Individuals with severe emphysema
Mean surface area for gas exchange / m <sup>2</sup>	118 ± 11	97 ± 8	30 ± 5
Mean total lung volume / cm <sup>3</sup>	4772 ± 223	6232 ± 410	6725 ± 384
Mean surface area for gas exchange : volume ratio	247.3 : 1		44.6 : 1

Fick's law of diffusion can be used to calculate a value for the effectiveness of the uptake of oxygen by the lungs.

This value can be calculated using the equation

$$\text{value} = \frac{\text{surface area} \times \text{concentration difference}}{\text{diffusion distance}}$$

The diffusion distance in alveoli is 0.5 µm.

The mean oxygen concentration in alveoli is 14 kPa and in the capillaries is 5 kPa.

The calculated value for healthy individuals is 2124.

(i) Calculate the value for individuals with severe emphysema.

(2)

Answer .....

(ii) Calculate the percentage difference between the value for individuals with severe emphysema and the value for individuals without emphysema.

(2)

Answer .....

**(Total for question = 4 marks)**

**Edexcel Biology A-level - Exchange of Substances**

**Q17.**

Describe the function of carrier proteins in a cell surface membrane.

**(4)**

.....

.....

.....

.....

.....

.....

.....

.....

.....

.....

.....

.....

.....

.....

.....

**(Total for question = 4 marks)**

## Edexcel Biology A-level - Exchange of Substances

**Q18.**

Scientists can use models to explain the need for a circulation system in animals.

The shapes in the diagram represent two different animals that live in water.  
The figures represent the height, width and breadth of the animals.

Determine why animal A does not need a circulation system but animal B does.

(4)

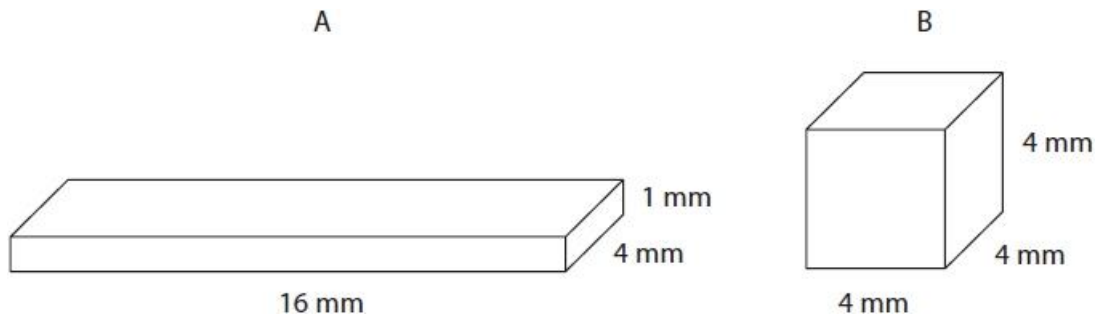

.....

.....

.....

.....

.....

.....

.....

.....

**(Total for question = 4 marks)**

## Edexcel Biology A-level - Exchange of Substances

**Q19.**

Blood plasma contains glucose dissolved in water. Glucose is a polar molecule that is taken up by muscle cells and used in the synthesis of glycogen.

Describe how glucose enters muscle cells through the cell membrane.

(2)

.....

.....

.....

.....

.....

.....

.....

**(Total for question = 2 marks)**

## Edexcel Biology A-level - Exchange of Substances

Q20.

The diagram shows part of a cell surface membrane.

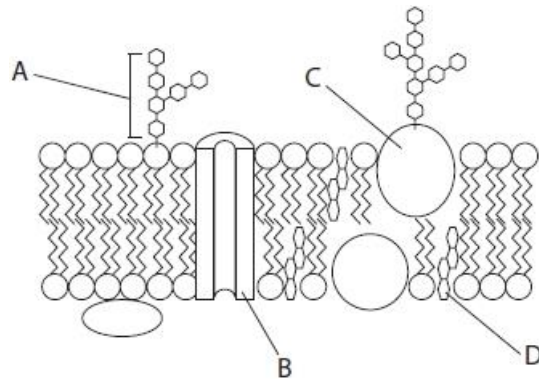

Which of the molecules labelled in the diagram is a glycoprotein?

(1)

- A
- B
- C
- D

(Total for question = 1 mark)

## Edexcel Biology A-level - Exchange of Substances

Q21.

Answer the questions with a cross in the boxes you think are correct . If you change your mind about an answer, put a line through the box  and then mark your new answer with a cross .

The structure of the cell surface membrane can be described by the fluid mosaic model.

The diagram shows the fluid mosaic model of the cell surface membrane.

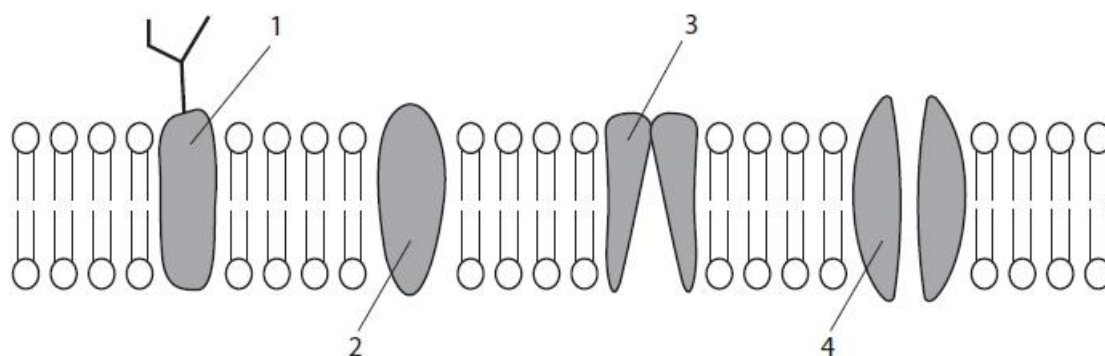

(i) Which of the shaded structures transport charged molecules or ions across the membrane?

- A 1 and 2 only
- B 3 and 4 only
- C 1, 2 and 3 only
- D 1, 2, 3 and 4

(1)

(ii) Which of the shaded structures contain both hydrophilic regions and hydrophobic regions?

- A 1 and 2 only
- B 3 and 4 only
- C 1, 2 and 3 only
- D 1, 2, 3 and 4

(1)

(iii) A student measured the width of the phospholipid bilayer shown on the diagram as 2.5 cm. The actual size of this bilayer is 5 nm. What is the approximate magnification of the diagram?

- A  $\times 5000$
- B  $\times 50\,000$
- C  $\times 500\,000$
- D  $\times 5\,000\,000$

(1)

**(Total for question = 3 marks)**

## Edexcel Biology A-level - Exchange of Substances

Q22.

\*Cells use ions in many different processes.

Ion transport across cell membranes is a fundamental property of all living cells.

The diagram shows some typical ion concentrations in healthy human cells and in the extracellular fluid.

All values are in  $\text{mmol dm}^{-3}$ .

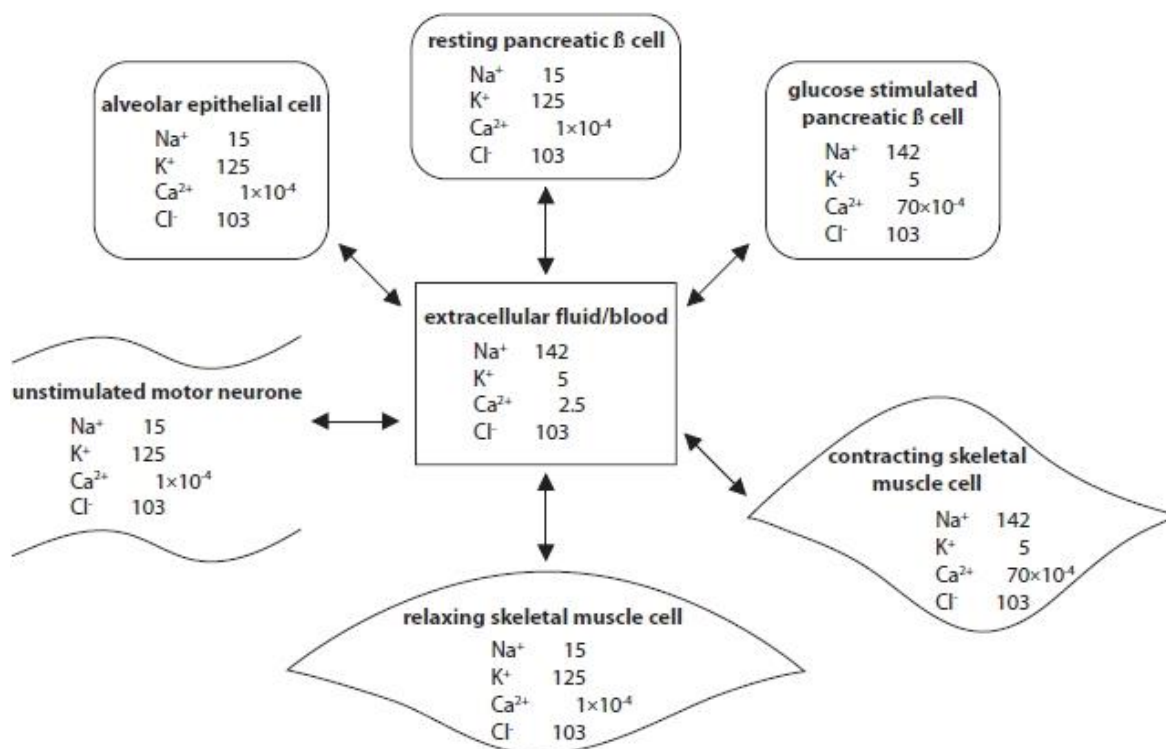



## Edexcel Biology A-level - Exchange of Substances

The tables show information about the human genome and types of transport channel in humans.

Some information about the human genome	
Number of genes in the human genome	approximately 20 000
Number of genes coding for membrane proteins	approximately 5 400
Number of genes coding for proteins involved in the transport of ions across cell membranes	more than 350
Number of diseases associated with mutations in genes involved in the transport of ions across cell membranes	more than 28
Organs and systems in which ion channel mutations cause disease	central nervous system, heart, lungs, pancreas and skeletal muscle

Type of transport channel	Number of each type of transport channel
Voltage gated ion channels	147
Chloride channels	17
Active transport	81

Discuss the importance of ion transport across membranes in human health and disease.

**(Total for question = 9 marks)**

## Edexcel Biology A-level - Exchange of Substances

Q23.

Pickling is a technique used to preserve food. Onions can be pickled by immersing them in a solution of sodium chloride.

A student investigated the effects of changing the concentration of sodium chloride solution on the mass of onion tissue. Small onions were peeled, had their tops and bottoms cut off and were weighed. The onions were then placed into covered beakers containing different concentrations of sodium chloride solution.

Six beakers were set up as shown in the diagram.

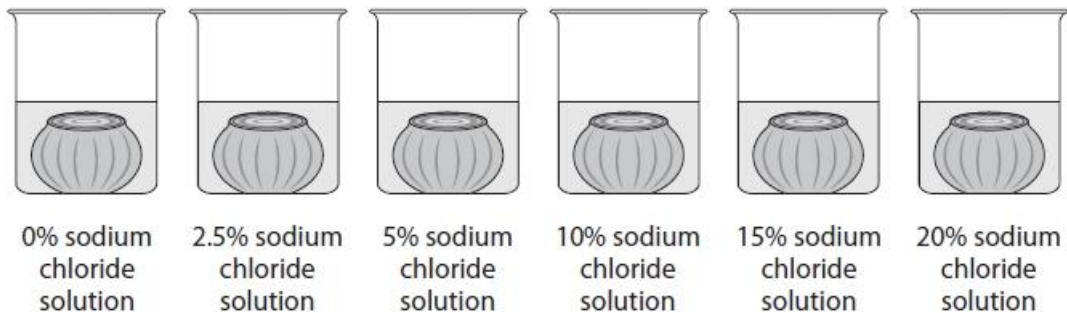

The beakers were left for two days. The onions were removed, blotted dry and reweighed. The investigation was repeated two more times.

The mean percentage change in mass was calculated.

The results of the investigation are shown in the table.

Sodium chloride solution (%)	Percentage change in mass (%)				SD
	1	2	3	Mean	
0.0	7.3	7.1	7.9	7.4	0.4
2.5	3.2	4.7	5.8	4.6	
5.0	-1.3	-0.9	-1.2	-1.1	0.2
10.0	0.6	-0.8	-1.9	-0.7	1.3
15.0	-2.1	-1.8	-2.9	-2.3	0.6
20.0	-2.2	-2.4	-1.9	-2.2	0.3

(i) Explain **one** way in which this investigation could be improved.

(2)

.....

.....

.....

## Edexcel Biology A-level - Exchange of Substances

(ii) Standard deviation can be calculated using the formula shown.

$$s = \sqrt{\frac{\sum(x - \bar{x})^2}{n - 1}}$$

Calculate the standard deviation for the 2.5% sodium chloride solution.

(2)

Answer .....

(iii) Deduce the effect of increasing the concentration of sodium chloride on the change in mass of the onion tissue.

(3)

.....

.....

.....

.....

.....

.....

.....

.....

.....

.....

.....

.....

.....

.....

.....

.....

**(Total for question = 7 marks)**

## Edexcel Biology A-level - Exchange of Substances

**Q24.**

All cells have a cell surface membrane.

Cell surface membranes regulate the movement of substances into and out of cells.

(i) Which of the following describes the movement of water by osmosis?

(1)

<input type="checkbox"/> <b>A</b>	against a solute concentration gradient	through a fully permeable membrane
<input type="checkbox"/> <b>B</b>	against a solute concentration gradient	through a partially permeable membrane
<input type="checkbox"/> <b>C</b>	down a solute concentration gradient	through a fully permeable membrane
<input type="checkbox"/> <b>D</b>	down a solute concentration gradient	through a partially permeable membrane

(ii) The concentration of potassium ions inside an animal cell is many times higher than the concentration of potassium ions in the extracellular fluid.

Which mechanism is responsible for the uptake of potassium ions by this animal cell?

(1)

- A** active transport
- B** exocytosis
- C** osmosis
- D** passive diffusion

(iii) Glucose enters cells by facilitated diffusion.

Which part of the cell surface membrane allows facilitated diffusion of glucose?

(1)

- A** cholesterol
- B** glycolipid
- C** phospholipid
- D** protein

**(Total for question = 3 marks)**

## Edexcel Biology A-level - Exchange of Substances

Q25.

Answer the questions with a cross in the boxes you think are correct . If you change your mind about an answer, put a line through the box  and then mark your new answer with a cross .

In the lungs, oxygen moves from the alveoli into red blood cells.

(i) How many times does an oxygen molecule cross a cell surface membrane to move from the centre of an alveolus to the centre of a red blood cell?

(1)

- A 2
- B 3
- C 4
- D 5

(ii) Oxygen enters the red blood cell by

(1)

- A active transport
- B diffusion
- C facilitated diffusion
- D osmosis

(Total for question = 2 marks)

## Edexcel Biology A-level - Exchange of Substances

Q26.

All organisms exchange gases with their environment.

Sailor's eyeball (*Valonia ventricosa*) is a single-celled, spherical organism.

One of these organisms can have a diameter of 1 cm to 4 cm.

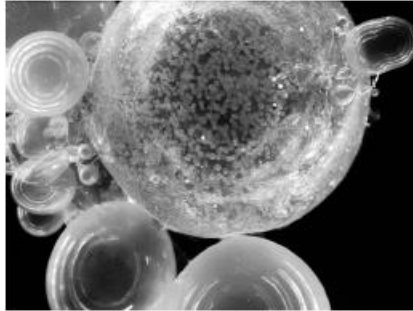

The table shows the diameter, surface area and volume of different *Valonia ventricosa* cells.

Diameter / cm	1	2	4
Surface area / cm <sup>2</sup>	3.14	12.57	50.27
Volume / cm <sup>3</sup>	0.52	4.19	

(i) The volume of a sphere can be calculated using the following equation.

$$V = \frac{4\pi r^3}{3}$$

What is the volume of a cell with a diameter of 4 cm?

(1)

- A 33.51 cm<sup>2</sup>
- B 33.51 cm<sup>3</sup>
- C 268.08 cm<sup>2</sup>
- D 268.08 cm<sup>3</sup>

(ii) Describe why single-celled organisms, such as *Valonia ventricosa*, do not need a specialised gas exchange surface.

(2)

.....

.....

.....

.....

.....

(Total for question = 3 marks)

## Edexcel Biology A-level - Exchange of Substances

Q27.

A student placed the same volume of starch suspension into two bags made of Visking tubing.

Each bag had a different length and width. The thickness of the Visking tubing for each bag was the same.

The membrane of the Visking tubing is partially permeable.

The same volume and concentration of amylase solution was added to the starch suspension.

Each bag was sealed and placed into test tubes containing the same volume of water, as shown in the diagram.

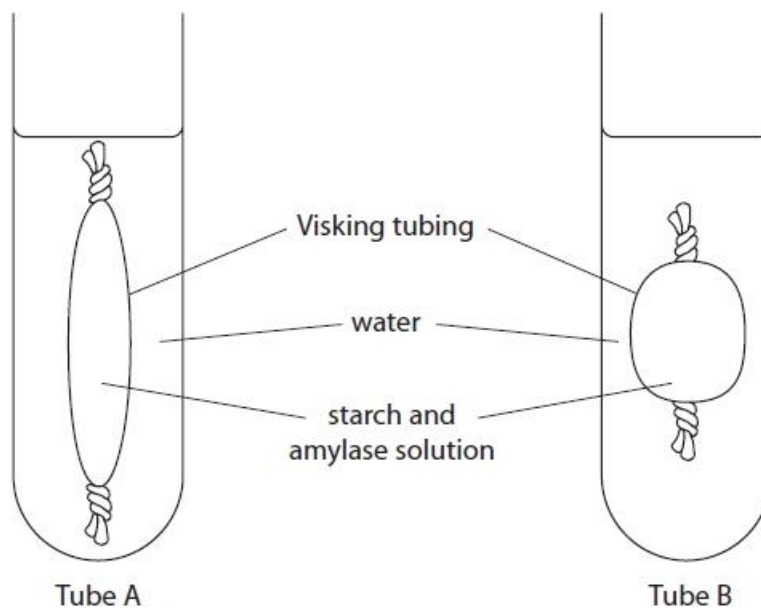

The water was tested at regular intervals for the presence of maltose.

Maltose was detected in the water in tube A before it was detected in the water in tube B.

Assess the factors that would cause maltose to be detected in tube A before tube B.

(4)

.....

.....

.....

.....

.....

.....

.....

.....

(Total for question = 4 marks)

## Edexcel Biology A-level - Exchange of Substances

**Q28.**

Hereditary spherocytosis is a condition that affects red blood cells.

This inherited condition is caused by a gene mutation that affects the shape of the cell surface membrane.

Describe the structure of the cell surface membrane.

**(3)**

.....

.....

.....

.....

.....

.....

.....

.....

.....

.....

.....

.....

.....

.....

.....

.....

.....

**(Total for question = 3 marks)**



## Edexcel Biology A-level - Exchange of Substances

Q29.

Answer the questions with a cross in the boxes you think are correct . If you change your mind about an answer, put a line through the box  and then mark your new answer with a cross .

The diagram shows the structure of a cell surface membrane.

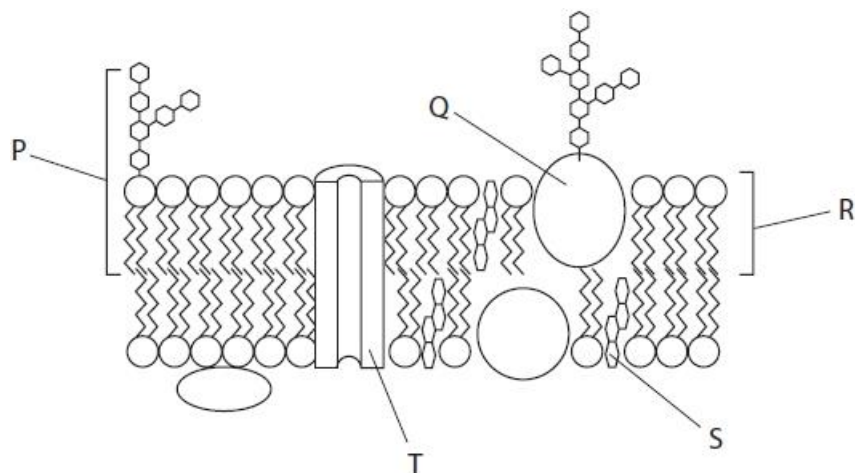

(i) The molecule labelled R is a phospholipid.

Give the name of the bond that joins a fatty acid molecule to a glycerol molecule in a phospholipid.

(1)

(ii) Which of the following describes molecule P?

(1)

- A carrier protein
- B cholesterol
- C glycolipid
- D glycoprotein

(iii) Which of the following molecules is involved in cell recognition?

(1)

- A Q
- B R
- C S
- D T

(iv) Which molecule allows ions to diffuse into a cell?

(1)

- A P
- B Q
- C R
- D T

(Total for question = 4 marks)

## Edexcel Biology A-level - Exchange of Substances

**Q30.**

All organisms exchange gases with their environment.

Mammalian lungs are adapted for rapid gas exchange.

Explain how the structure of the human lungs enables rapid gas exchange.

(4)

.....

.....

.....

.....

.....

.....

.....

.....

.....

.....

.....

.....

.....

.....

.....

.....

.....

.....

.....

.....

.....

.....

**(Total for question = 4 marks)**

## Edexcel Biology A-level - Exchange of Substances

### Mark Scheme

Q1.

Question Number	Answer	Additional Guidance	Mark
	<p>An explanation which makes reference to the following:</p> <ul style="list-style-type: none"> <li>betalain molecules are too large (to move through the cell membrane) (1)</li> <li>there are no {carrier / channel} proteins for betalain molecules (to move through) (1)</li> <li>betalain molecules are polar and {are repelled by hydrophobic fatty acid tails / cannot move through fatty acid tails}</li> </ul>		(3)

Q2.

Question Number	Answer	Additional Guidance	Mark
	<p>An explanation that makes reference to three of the following:</p> <ul style="list-style-type: none"> <li>thinner blood-gas barrier (1)</li> <li>because of thinner { alveolar walls / capillary walls / extracellular matrix layer } (1)</li> <li>therefore a reduced diffusion distance (1)</li> <li>a faster rate of { diffusion / gas exchange } (1)</li> </ul>	ALLOW greater rate	3

Q3.

Question Number	Answer	Additional Guidance	Mark
	<ul style="list-style-type: none"> <li>width of X to Y ÷ magnification (1)</li> <li>correct answer with appropriate units (1)</li> </ul>	<p><u>Example of calculation</u></p> <p>50(mm) ÷ 5 000 000 / 5(cm) ÷ 5 000 000</p> <p>10 nm / 0.01 µm</p>	(2)

## Edexcel Biology A-level - Exchange of Substances

Q4.

Question Number	Answer	Additional Guidance	Mark
(i)	<ul style="list-style-type: none"><li>• 4 phospholipids drawn correctly with phosphate head and 2 fatty acid tails (1)</li><li>• the phosphate head should be in the water and fatty acid tails should be in the air (1)</li></ul>		(2)

Question Number	Answer	Additional Guidance	Mark
(ii)	<p>C – phospholipids, channel proteins and cholesterol</p> <p><i>A is incorrect because phospholipids and cholesterol also have hydrophilic regions</i></p> <p><i>B is incorrect because cholesterol also has hydrophilic regions</i></p> <p><i>D is incorrect because channel proteins and cholesterol also have hydrophilic regions</i></p>		(1)

## Edexcel Biology A-level - Exchange of Substances

Q5.

Question Number	Answer	Additional Guidance	Mark
	<p>An answer that makes reference to three of the following:</p> <p><u>Similarities</u></p> <ul style="list-style-type: none"> <li>both move molecules through the {phospholipid bilayer / cell surface membrane} (1)</li> <li>(in both) molecules can move through proteins (1)</li> </ul> <p><u>Differences</u></p> <ul style="list-style-type: none"> <li>diffusion occurs down a concentration gradient whereas active transport occurs against a concentration gradient (1)</li> <li>diffusion is {passive / does not require ATP} whereas active transport requires ATP (1)</li> </ul>	<p>ALLOW { partially / semi permeable } membrane</p> <p>ALLOW diffusion from high to low concentration and active transport from low to high concentration</p> <p>ALLOW energy for ATP</p>	(3)

Q6.

Question Number	Answer	Additional Guidance	Mark
	<p>An explanation which makes reference to three of the following:</p> <p><u>Similarities</u></p> <ul style="list-style-type: none"> <li>both processes involve vesicles (1)</li> <li>both processes involve energy from ATP (1)</li> </ul> <p><u>Differences</u></p> <ul style="list-style-type: none"> <li>exocytosis involves {molecules / substances} leaving the cell whereas endocytosis involves {molecules / substances} entering the cell (1)</li> <li>exocytosis involves vesicles fusing with cell surface membrane whereas endocytosis involves the formation of vesicles (from the cell surface membrane) (1)</li> </ul>	<p>IGNORE secretory</p> <p>IGNORE active transport</p>	(3)

## Edexcel Biology A-level - Exchange of Substances

Q7.

Question Number	Answer	Additional guidance	Mark
(i)	<p>An explanation which makes reference to the following:</p> <ul style="list-style-type: none"> <li>• sodium ions are being moved against the concentration gradient (1)</li> <li>• (through proteins) using active transport (1)</li> </ul>	<p>ALLOW from low concentration in tissue fluid to a higher concentration in cytoplasm</p>	(2)

Question Number	Answer	Additional guidance	Mark
(ii)	<p>A description which makes reference to the following:</p> <ul style="list-style-type: none"> <li>• by facilitated diffusion (1)</li> <li>• through (carrier) proteins (in the phospholipid bilayer) (1)</li> </ul>	<p>ignore channel proteins</p>	(2)

## Edexcel Biology A-level - Exchange of Substances

Q8.

Question Number	Answer	Additional Guidance	Mark
(i)	<p>A description that makes reference to two of the following:</p> <ul style="list-style-type: none"> <li>carrier protein (in cell surface membrane)</li> <li>(glucose moves from) high to low concentration</li> <li>glucose binds to (carrier) protein / (carrier) protein changes shape to move glucose (across the membrane) (1)</li> </ul>	<p>IGNORE channel protein</p> <p>ALLOW 'down a concentration gradient'</p>	(2)

Question Number	Answer	Additional Guidance	Mark
(ii)	<p>An explanation that makes reference to three of the following:</p> <ul style="list-style-type: none"> <li>polymer of glucose</li> <li>to provide glucose for respiration</li> <li>{branched / contains 1,6-glycosidic bonds / has many terminal ends} for rapid hydrolysis</li> <li>compact to allow large amount (of glucose / energy) to be stored in a small space / insoluble therefore no osmotic effect on cells</li> </ul>	<p>ALLOW polysaccharide /made of many glucose monomers DO NOT ALLOW <math>\beta</math>- glucose</p> <p>IGNORE 'easy to hydrolyse' ALLOW break down instead of hydrolyse</p>	(3)

Q9.

Question Number	Answer	Additional Guidance	Mark
(i)	<p>An answer which makes reference to the following:</p> <ul style="list-style-type: none"> <li>cell recognition / receptors (on cell surface membrane) / antigens</li> </ul>	ALLOW involved in cell signalling	(1)

## Edexcel Biology A-level - Exchange of Substances

Question Number	Answer	Additional Guidance	Mark
(ii)	<p>An explanation which makes reference to the following:</p> <ul style="list-style-type: none"> <li>(phospholipid molecule) contains a {polar / hydrophilic} (phosphate) head and {non-polar / hydrophobic} fatty acid chains (1)</li> <li>allows {fat-soluble/non-polar} molecules to pass through (the membrane) (1)</li> <li>{polar / ionic} molecules cannot pass through (phospholipid bilayer) (1)</li> </ul>	<p>ALLOW tail for fatty acid chain</p> <p>ALLOW charged</p>	(3)

### Q10.

Question Number	Answer
	<p>Answers will be credited according to candidate's knowledge and understanding of the material in relation to the qualities and skills outlined in the generic mark scheme.</p> <p>The indicative content below is not prescriptive and candidates are not required to include all the material which is indicated as relevant. Additional content included in the response must be scientific and relevant.</p> <ul style="list-style-type: none"> <li>rate of diffusion would be lower with abnormal heart</li> <li>blood entering lungs from an abnormal heart has more oxygen, 8kPa, than blood entering lungs from a normal heart, 5kPa</li> <li>oxygen in blood increased by only 2kPa instead of 8kPa with abnormal heart</li> <li>resulting in a smaller difference in concentration between the alveoli and the red blood cells i.e. 14-8/14-5 or 6 and 9kPa</li> <li>the surface area of the alveoli and distance for diffusion are not affected</li> <li>Fick's law states that concentration gradient is proportional to rate of gas exchange</li> <li>a lower concentration gradient for oxygen between the alveoli and the blood results in a lower rate of oxygen diffusion</li> </ul> <p><b>NOTE</b> – 'the pieces of scientific information provided' could be any from: the information about the defective heart / diagram of alveolus / table of data</p>

Level	Mark	Descriptor
0	0	No awardable content
1	1-2	<p>An answer may be attempted but with limited interpretation or analysis of the scientific information with a focus on mainly just one piece of scientific information.</p> <p>The explanation will contain basic information with some attempt made to link knowledge and understanding to the given context.</p>
2	3-4	<p>An answer will be given with occasional evidence of analysis, interpretation and/or evaluation of the pieces of scientific information provided.</p> <p>The explanation shows some linkages and lines of scientific reasoning with some structure.</p>
3	5-6	<p>An answer is made which is supported throughout by sustained application of relevant evidence of analysis, interpretation and/or evaluation of the pieces of scientific information provided.</p> <p>The explanation shows a well-developed and sustained line of scientific reasoning which is clear and logically structured.</p>



## Edexcel Biology A-level - Exchange of Substances

Q11.

Question number	Answer	Additional guidance	Mark
(i)	<ul style="list-style-type: none"> <li>conversion of surface area from m<sup>2</sup> to cm<sup>2</sup> (1)</li> <li>correctly dividing surface area by volume to determine ratio (1)</li> </ul>	<p>Example of Calculation:</p> <p>97 x 10000 = 970 000</p> <p>divided by lung volume of 6232</p> <p>Correct ratio of <b>155.6 : 1</b> (ALLOW 155.65 :1)</p> <p>ALLOW one mark only for <b>0.0155 : 1 / 0.156 : 1 / 155.6</b></p> <p>Correct answer with no working gains full marks</p>	(2)

Question number	Answer	Mark
(ii)	<p>The only correct answer is D – Student’s t-test</p> <p><i>A is not correct because chi- squared does not test difference between means</i></p> <p><i>B is not correct because there is no correlation to test</i></p> <p><i>C is not correct because SD does not compare means</i></p>	(1)

Question number	Answer	Additional guidance	Mark
(iii)	<p>An answer that makes reference to two of the following points:</p> <ul style="list-style-type: none"> <li>different { height / weight / mass } (1)</li> <li>different { gender / sex } (1)</li> <li>different age (1)</li> </ul>	<p>IGNORE 'size'</p> <p>ALLOW 'men have larger lungs than women'</p>	(2)

Question number	Answer	Additional guidance	Mark
(iv)	<ul style="list-style-type: none"> <li>to allow (valid) comparison / show differences (1)</li> </ul>		(1)

## Edexcel Biology A-level - Exchange of Substances

Q12.

Question Number	Answer	Additional Guidance	Mark
	<p>An answer that makes reference to the following:</p> <ul style="list-style-type: none"> <li>exocytosis involves {molecules / substances} leaving the cell whereas endocytosis involves {molecules / substances} entering the cell (1)</li> <li>exocytosis involves vesicles fusing with cell surface membrane whereas endocytosis involves the formation of vesicles (from the cell surface membrane) (1)</li> </ul>	<p>ALLOW exocytosis involves vesicles fusing with cell surface membrane whereas endocytosis does not involve vesicles fusing with cell surface membrane</p>	(2)

Q13.

Question Number	Answer	Additional Guidance	Mark
	<p>An explanation that makes reference to the following:</p> <ul style="list-style-type: none"> <li>hydrophilic parts associate with water (1)</li> <li>hydrophobic parts {associate with each other / repel water }(1)</li> <li>a bilayer forms with hydrophobic parts pointing { in towards the centre of the bilayer / towards each other } (1)</li> </ul>	<p>ALLOW converse</p> <p>ALLOW phosphate groups associate with water</p> <p>ALLOW fatty acids face away from water</p> <p>ALLOW annotated diagram to show arrangement of phospholipids</p>	3

## Edexcel Biology A-level - Exchange of Substances

Q14.

Question number	Answer	Additional guidance	Mark
	<p>An explanation that makes reference to three of the following points:</p> <ul style="list-style-type: none"> <li>• { smaller surface area / increased diffusion distance } for gas exchange (1)</li> <li>• therefore reduction in oxygen uptake (1)</li> <li>• therefore less oxygen for aerobic respiration (1)</li> <li>• leading to more anaerobic respiration (causing fatigue) (1)</li> </ul>	ALLOW smaller SA:vol	(3)

Q15.

Question Number	Answer	Additional Guidance	Mark
	<p>An explanation that makes reference to the following:</p> <ul style="list-style-type: none"> <li>• hydrophilic region (of phospholipid) orientated towards water (1)</li> <li>• (and) hydrophobic regions away from the water (1)</li> <li>• (but need the two layers as) { water-based / aqueous } solution either side of the cell membrane (1)</li> </ul>	<p>ALLOW phosphate head / polar region</p> <p>ALLOW hydrocarbon chain / fatty acid tails</p> <p>e.g. separating tissue fluid from cytoplasm</p>	(3)

## Edexcel Biology A-level - Exchange of Substances

Q16.

Question number	Answer	Additional guidance	Mark
(i)	<ul style="list-style-type: none"> <li>values substituted into the equation (1)</li> <li>correct answer (1)</li> </ul>	<u>Example of calculation:</u> $(30 \times 9) \div 0.5$ = 540 Correct answer with no working gains full marks	(2)
(ii)	<ul style="list-style-type: none"> <li>calculation of the difference using the value from (i) (1)</li> <li>correct answer (1)</li> </ul>	<u>Example of calculation:</u> $2124 - 540 (= 1584)$  $1584 / 2124 \times 100 = 74.6\%$ or 75%  ECF full marks if calculated correctly for value other than 540  Correct answer with no working gains full marks	(2)

Q17.

Question Number	Answer	Additional Guidance	Mark
	A description that makes reference to four of the following: <ul style="list-style-type: none"> <li>involved in facilitated diffusion (1)</li> <li>movement of { large molecules / polar molecules / ions } (1)</li> <li>(facilitated diffusion) from a high concentration to a low concentration (1)</li> <li>involved in active transport (1)</li> <li>needs ATP to move molecules against concentration gradient (1)</li> </ul>	ALLOW charged molecules  ALLOW needs ATP to move molecules from low concentration to high concentration	(4)

## Edexcel Biology A-level - Exchange of Substances

Q18.

Question Number	Answer	Additional guidance	Mark
	<p>An answer the makes reference to four of the following:</p> <ul style="list-style-type: none"> <li>• both have same volume (1)</li> <li>• animal A has a larger surface area (1)</li> <li>• animal A has a larger surface area to volume ratio (1)</li> <li>• so sufficient (surface area in animal A) for diffusion (1)</li> <li>• distance to cells in centre of A is shorter than for B allowing {quicker/sufficient} diffusion / shorter diffusion distance (in A) (1)</li> </ul>	<p>ALLOW both have a volume of 64 mm<sup>3</sup></p> <p>ALLOW converse ALLOW figures given (e.g. 168 mm<sup>2</sup> v 96mm<sup>2</sup>) or difference given as 72 mm<sup>2</sup></p> <p>ALLOW {168:64 / 2.6:1} compared to {96:64 / 1.5:1}</p> <p>ALLOW converse</p> <p>ALLOW converse</p>	(4)

Q19.

Question Number	Answer	Additional Guidance	Mark
	<p>A description that makes reference to the following:</p> <ul style="list-style-type: none"> <li>• carrier proteins (located in membrane) (1)</li> <li>• (glucose enters by) facilitated diffusion (1)</li> </ul>	ALLOW channel proteins	(2)

Q20.

Question Number	Answer	Mark
	C	(1)

## Edexcel Biology A-level - Exchange of Substances

Q21.

Question Number	Answer	Mark
(i)	<p><i>The only correct answer is B 3 and 4 only</i></p> <p><i>A is incorrect because 1 and 2 do not transport charged molecules or ions across membranes</i></p> <p><i>C is incorrect because 1 and 2 do not transport charged molecules or ions across membranes and 4 does transport</i></p> <p><i>D is incorrect because 1 and 2 do not transport charged molecules or ions across membranes</i></p>	(1)

Question Number	Answer	Mark
(ii)	<p><i>The only correct answer is D 1, 2, 3 and 4</i></p> <p><i>A is incorrect because 3 and 4 also have both these regions</i></p> <p><i>B is incorrect because 1 and 2 also have both these regions</i></p> <p><i>C is incorrect because 4 also has both these regions</i></p>	(1)

Question Number	Answer	Mark
(iii)	<p>D - x 5 000 000</p> <p><i>The only correct answer is D – (2.5 ÷ 5) x 10<sup>7</sup></i></p> <p><i>A is incorrect</i></p> <p><i>B is incorrect</i></p> <p><i>C is incorrect</i></p>	(1)

## Edexcel Biology A-level - Exchange of Substances

Q22.

Question number	Answer	Mark
	<p>Answers will be credited according to candidate's deployment of knowledge and understanding of the material in relation to the qualities and skills outlined in the generic mark scheme.</p> <p>The indicative content below is not prescriptive, and candidates are not required to include all the material which is indicated as relevant. Additional content included in the response must be scientific and relevant.</p> <p>Reference to role of ions in</p> <ul style="list-style-type: none"> <li>• nerve conduction</li> <li>• release of neurotransmitters</li> <li>• muscle contraction</li> </ul> <p>Mention of</p> <ul style="list-style-type: none"> <li>• passive diffusion through ion channels</li> <li>• active transport against concentration gradients</li> </ul> <p>Examples of ion transport</p> <ul style="list-style-type: none"> <li>• active transport – sodium potassium pump</li> <li>• hydrogen ions in chemiosmosis</li> <li>• calcium channels in pre-synaptic knob</li> <li>• sodium and potassium channels in neurones</li> </ul> <p>Idea that ions moving down a concentration gradient can do work</p> <ul style="list-style-type: none"> <li>• ATP synthase in chemiosmosis</li> <li>• cotransporters</li> </ul> <p>Ion channels in disease</p> <ul style="list-style-type: none"> <li>• chloride channels in cystic fibrosis</li> <li>• credit any other sensible suggestions</li> <li>•</li> </ul> <p>Ideas around control</p> <ul style="list-style-type: none"> <li>• lots of different genes/proteins involved in transporting ions across membranes</li> <li>• specificity of channels for particular ions</li> <li>• control of opening and closing of different channels</li> </ul>	<p><b>(9)</b></p>

## Edexcel Biology A-level - Exchange of Substances

Level	Marks		Additional Guidance
0	0	No awardable content	
1	1-3	<p>Demonstrates isolated elements of biological knowledge and understanding to the given context with generalised comments made.</p> <p>Vague statements related to consequences are made with limited linkage to a range of scientific ideas, processes, techniques and procedures.</p> <p>The discussion will contain basic information with some attempt made to link knowledge and understanding to the given context.</p>	<p>simple description of data provided</p> <p>or</p> <p>discussion of one aspect from specification e.g. role of ions in action potentials / muscle contraction / mucus production</p>
2	4-6	<p>Demonstrates adequate knowledge and understanding by selecting and applying some relevant biological facts/concepts.</p> <p>Consequences are discussed which are occasionally supported through linkage to a range of scientific ideas, processes, techniques and procedures.</p> <p>The discussion shows some linkages and lines of scientific reasoning with some structure.</p>	<p>Level 1 criteria plus</p> <p>discussion of another aspects from specification including consideration in (disease / ill-health) in at least one</p>
3	7-9	<p>Demonstrates comprehensive knowledge and understanding by selecting and applying relevant knowledge of biological facts/concepts.</p> <p>Consequences are discussed which are supported throughout by sustained linkage to a range of scientific ideas, processes, techniques or procedures.</p>	<p>Level 2 criteria plus</p> <p>appropriate use of data from tables linked to health or disease</p> <p>or</p>
		<p>The discussion shows a well-developed and sustained line of scientific reasoning which is clear and logically structured.</p>	<p>attempt at higher level reasoning e.g explaining role of (ion gradients / active transport of ions) expanding on role of mutations in disease beyond cystic fibrosis / discussion of channel specificity or evolution of variety of channels with many functions</p>



# Edexcel Biology A-level - Exchange of Substances

Q23.

Question Number	Answer	Additional Guidance	Mark
(i)	<p>explanation that makes reference to the following:</p> <ul style="list-style-type: none"> <li>• same {age / type} of onion (1)</li> <li>• increases {repeatability / validity} (1)</li> </ul> <p>OR</p> <ul style="list-style-type: none"> <li>• smaller concentration intervals (1)</li> <li>• increasing {confidence in / validity of} conclusion (1)</li> </ul> <p>OR</p> <ul style="list-style-type: none"> <li>• same {temperature / surface area of onion} (1)</li> <li>• due to effect on osmosis (1)</li> </ul>		(2)

Question Number	Answer	Additional Guidance	Mark
(ii)	<ul style="list-style-type: none"> <li>• correct calculation of numerator (1)</li> <li>• correct calculation of standard deviation (1)</li> </ul>	<p><u>Example of calculation</u></p> $\sum (xx - x\bar{x})^2 = 3.41$ $(3.2 - 4.6)^2 + (4.7 - 4.6)^2 + (5.8 - 4.6)^2$ $\frac{33.4444}{22} =$ <p>1.3 / 1.31 / 1.306 / 1.3057</p> <p>Correct answer no working scores full marks</p> <p>ALLOW ECF if number other than 3.41 calculated</p>	(2)

## Edexcel Biology A-level - Exchange of Substances

Question Number	Answer	Additional Guidance	Mark
(iii)	<p>An answer which makes reference to three of the following:</p> <ul style="list-style-type: none"> <li>• 2.5% (sodium chloride solution) resulted in an increase in mass (1)</li> <li>• an increase (in sodium chloride solution) from 5% to {15% / 20%} resulted in a loss in mass (1)</li> <li>• because of the movement of water by osmosis (1)</li> <li>• (SD) values overlap for {5% and 10% / 10% and 15% / 10% and 20% / 15% and 20%} (sodium chloride solution) therefore no (significant) difference (1)</li> </ul>		(3)

Q24.

Question Number	Answer	Mark		
(i)	<p><b>The only correct answer is B -</b></p> <table border="1" style="margin-left: 20px;"> <tr> <td>against a solute concentration gradient</td> <td>through a partially permeable membrane</td> </tr> </table> <p>A is not correct because in osmosis water moves against a solute concentration gradient - through a partially permeable membrane</p> <p>C is not correct because in osmosis water moves against a solute concentration gradient - through a partially permeable membrane</p> <p>D is not correct because in osmosis water moves against a solute concentration gradient - through a partially permeable membrane</p>	against a solute concentration gradient	through a partially permeable membrane	<b>1</b>
against a solute concentration gradient	through a partially permeable membrane			

Question Number	Answer	Mark
(ii)	<p><b>The only correct answer is A - Active transport</b></p> <p>B is not correct because exocytosis is an export process</p> <p>C is not correct because osmosis describes the movement of water (solvent) molecules</p> <p>D is not correct because passive diffusion take place down a concentration gradient</p>	<b>1</b>

## Edexcel Biology A-level - Exchange of Substances

Question Number	Answer	Mark
(iii)	<p><b>The only correct answer is D – Protein</b></p> <p>A is not correct because carrier molecules or channel used for facilitated diffusion are proteins</p> <p>B is not correct because carrier molecules or channel used for facilitated diffusion are proteins</p> <p>C is not correct because carrier molecules or channel used for facilitated diffusion are proteins</p>	<b>1</b>

**Q25.**

Question Number	Answer	Mark
(i)	<p><b>The only correct answer is D - 5</b></p> <p><i>A is not correct because oxygen has to travel across both sides of a cell in the alveolus wall plus both sides of the capillary wall cell as well as across the cell surface membrane of a red blood cell. This summates to 5, not 2.</i></p> <p><i>B is not correct because oxygen has to travel across both sides of a cell in the alveolus wall plus both sides of the capillary wall cell as well as across the cell surface membrane of a red blood cell. This summates to 5, not 3.</i></p> <p><i>C is not correct because oxygen has to travel across both sides of a cell in the alveolus wall plus both sides of the capillary wall cell as well as across the cell surface membrane of a red blood cell. This summates to 5, not 4.</i></p>	<b>(1)</b>

Question Number	Answer	Mark
(ii)	<p><b>The only correct answer is B (diffusion)</b></p> <p><i>A is not correct because oxygen does not enter a red blood cell by active transport</i></p> <p><i>C is not correct because oxygen does not enter a red blood cell through facilitated diffusion</i></p> <p><i>D is not correct because oxygen does not enter a red blood cell through osmosis</i></p>	<b>(1)</b>

## Edexcel Biology A-level - Exchange of Substances

Q26.

Question Number	Answer	Mark
(i)	<p>The only correct answer is B <math>33.51\text{cm}^3</math></p> <p><i>A is not correct because volume needs <math>\text{cm}^3</math></i></p> <p><i>C is not correct because volume needs <math>\text{cm}^3</math></i></p> <p><i>D is not correct because the equation requires the diameter to be halved</i></p>	(1)

Question Number	Answer	Additional Guidance	Mark
(ii)	<p>A description that makes reference to two of the following:</p> <ul style="list-style-type: none"> <li>• they can rely on diffusion to {take in oxygen / remove wastes} (1)</li> <li>• large surface area to volume ratio (allows diffusion to occur at a sufficient rate) (1)</li> <li>• short diffusion distance (1)</li> </ul>		(2)

Q27.

Question Number	Answer	Additional Guidance	Mark
	<p>An answer which makes reference to four of the following:</p> <ul style="list-style-type: none"> <li>• for Tube A the surface area was greater (than tubing B / shorter distance for diffusion in Tube A) (1)</li> <li>• (Ficks law states that) rate of diffusion is {proportional to surface area / inversely proportional to distance for diffusion} (1)</li> <li>• (therefore) increased rate of diffusion (of maltose) (1)</li> <li>• Tube A could have had a higher {concentration of starch / temperature} (1)</li> <li>• a higher {concentration gradient / higher temperature} would increase the rate of diffusion (1)</li> </ul>	<p>ALLOW length of tubing A was greater</p> <p>ALLOW movement for diffusion</p>	(4)

## Edexcel Biology A-level - Exchange of Substances

Q28.

Question Number	Answer	Additional guidance	Mark
	<p>A description that makes reference to three of the following</p> <ul style="list-style-type: none"> <li>cell membrane is (mainly) phospholipids and protein (1)</li> <li>phospholipids form a bilayer (1)</li> <li>proteins float in the phospholipids / change position / fluidmosaic model (1)</li> <li>proteins may span the bilayer or be located in only onelayer (1)</li> </ul>	<p>ALLOW proteins embedded in the phospholipid bilayer</p> <p>ALLOW proteins may be intrinsic /extrinsic IGNORE function of proteins such as carrier/ channel</p>	(3)

Q29.

Question Number	Answer	Additional guidance	Mark
(i)	<ul style="list-style-type: none"> <li>ester (bond) (1)</li> </ul>	ALLOW covalent (bond)	(1)

Question Number	Answer	Mark
(ii)	<p>The only correct answer is – C - glycolipid</p> <p>A is incorrect because structure P is not a carrier protein</p> <p>B is incorrect because structure S is cholesterol</p> <p>D is incorrect because structure R is a glycoprotein</p>	(1)

Question Number	Answer	Mark
(iii)	<p>The only correct answer is – A - Q</p> <p>B is incorrect because structure R is not involved in cell recognition</p> <p>C is incorrect because structure S is not involved in cell recognition</p> <p>D is incorrect because structure T is not involved in cell recognition</p>	(1)

## Edexcel Biology A-level - Exchange of Substances

Question Number	Answer	Mark
(iv)	<p>The only correct answer is – D - T which is a channel protein</p> <p>A is incorrect because structure P is involved in cell recognition</p> <p>B is incorrect because structure Q does not allow ions to diffuse into a cell</p> <p>C is incorrect because structure R does not allow ions to diffuse into a cell</p>	(1)

### Q30.

Question Number	Answer	Additional Guidance	Mark
	<p>An explanation that makes reference to the following:</p> <ul style="list-style-type: none"> <li>• many alveoli provide a large surface area (1)</li> <li>• {alveoli / capillaries} have walls that are one cell thick providing a short distance for diffusion (1)</li> <li>• high concentration gradient maintained by {circulation / ventilation} (1)</li> <li>• extensive capillary network around alveoli provides large surface area for gas exchange (1)</li> </ul>	ALLOW thin walls	(4)