

Please check the examination details below before entering your candidate information

Candidate surname

Other names

Centre Number

Candidate Number

**Pearson Edexcel**  
**Level 1/Level 2 GCSE (9–1)**

--	--	--	--	--

--	--	--	--	--

**Friday 24 May 2019**

Afternoon (Time: 1 hour 45 minutes)

Paper Reference **1DT0/1E**

**Design and Technology**

**Component 1: Textiles**

**You must have:**

Calculator, ruler, HB pencil, protractor, compass

Total Marks

## Instructions

- Use **black** ink or ball-point pen.
- **Fill in the boxes** at the top of this page with your name, centre number and candidate number.
- Answer **all** questions.
- Answer the questions in the spaces provided  
– *there may be more space than you need.*
- Calculators may be used.
- Any diagrams may NOT be accurately drawn, unless otherwise indicated.
- You must **show all your working out** with **your answer clearly identified** at the **end of your solution**.

## Information

- The total mark for this paper is 100.
- The marks for **each** question are shown in brackets  
– *use this as a guide as to how much time to spend on each question.*

## Advice

- Read each question carefully before you start to answer it.
- Try to answer every question.
- Check your answers if you have time at the end.

Turn over ►

P59666A

©2019 Pearson Education Ltd.

1/1/1/1/1/1/1/1/1



  
Pearson

## SECTION A – CORE



**Answer ALL questions. Write your answers in the spaces provided.**

- 1** (a) The materials that products are made from are chosen because of their properties.

Figure 1 shows a table of products.

For each of the products shown, give a property of the material it is made from that makes the material suitable for the product.

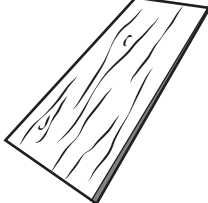
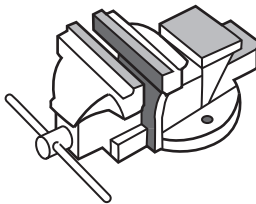
The first one has been done for you.

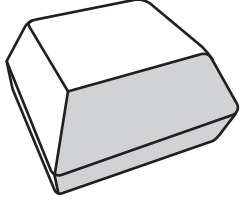
Product	Product material	Property
	Biodegradable plastic shopping bag	Will degrade in soil
	Cedar roof tile	(1) (i) .....
	Cast iron workshop vice	(1) (ii) .....
	Polyester raincoat	(1) (iii) .....
	Solid white board burger package	(1) (iv) .....

**Figure 1**

DO NOT WRITE IN THIS AREA

DO NOT WRITE IN THIS AREA

DO NOT WRITE IN THIS AREA



(b) Figure 2 shows a table with the number of plastic bags given away in England.

Year	Number of bags given away (billions)
2014	7.6
2015	5.4

**Figure 2**

Calculate the percentage reduction in the number of plastic bags given away between 2014 and 2015.

Give your answer to the nearest whole number.

(2)

Percentage reduction .....

(c) In 2015 charging for carrier bags was introduced resulting in a reduction in the number of bags being manufactured.

Explain **one** negative effect of this reduction for the manufacturer.

(2)

.....

.....

.....

**(Total for Question 1 = 8 marks)**



- 2 Figure 3 shows a drawing of a fabric play cube for young children.  
The fabric play cube has a side length of 60 mm.

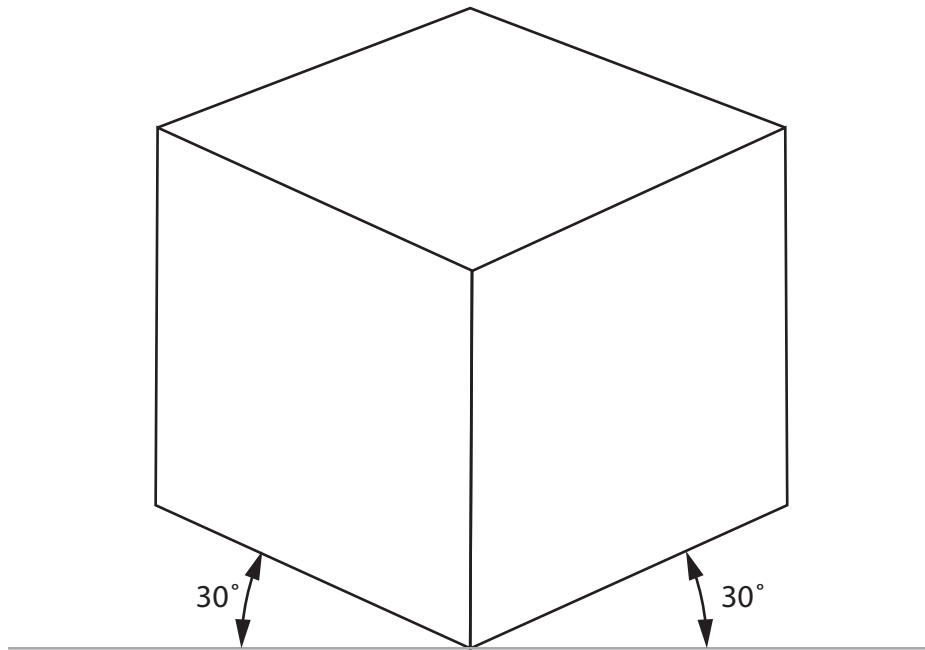

**Figure 3**

- (a) Name the communication technique that has been used to produce the drawing shown in Figure 3.

(1)

- (b) A prototype play cube was made from calico.

Explain **one** reason for using calico for the prototype play cube.

(2)



DO NOT WRITE IN THIS AREA

DO NOT WRITE IN THIS AREA

DO NOT WRITE IN THIS AREA

(c) The pattern for the prototype play cube was made from a single net.

Draw a net for the play cube on the grid provided below.

Do not include any seam allowance.

Use a dashed line - - - - to show where the net would be folded.

(4)

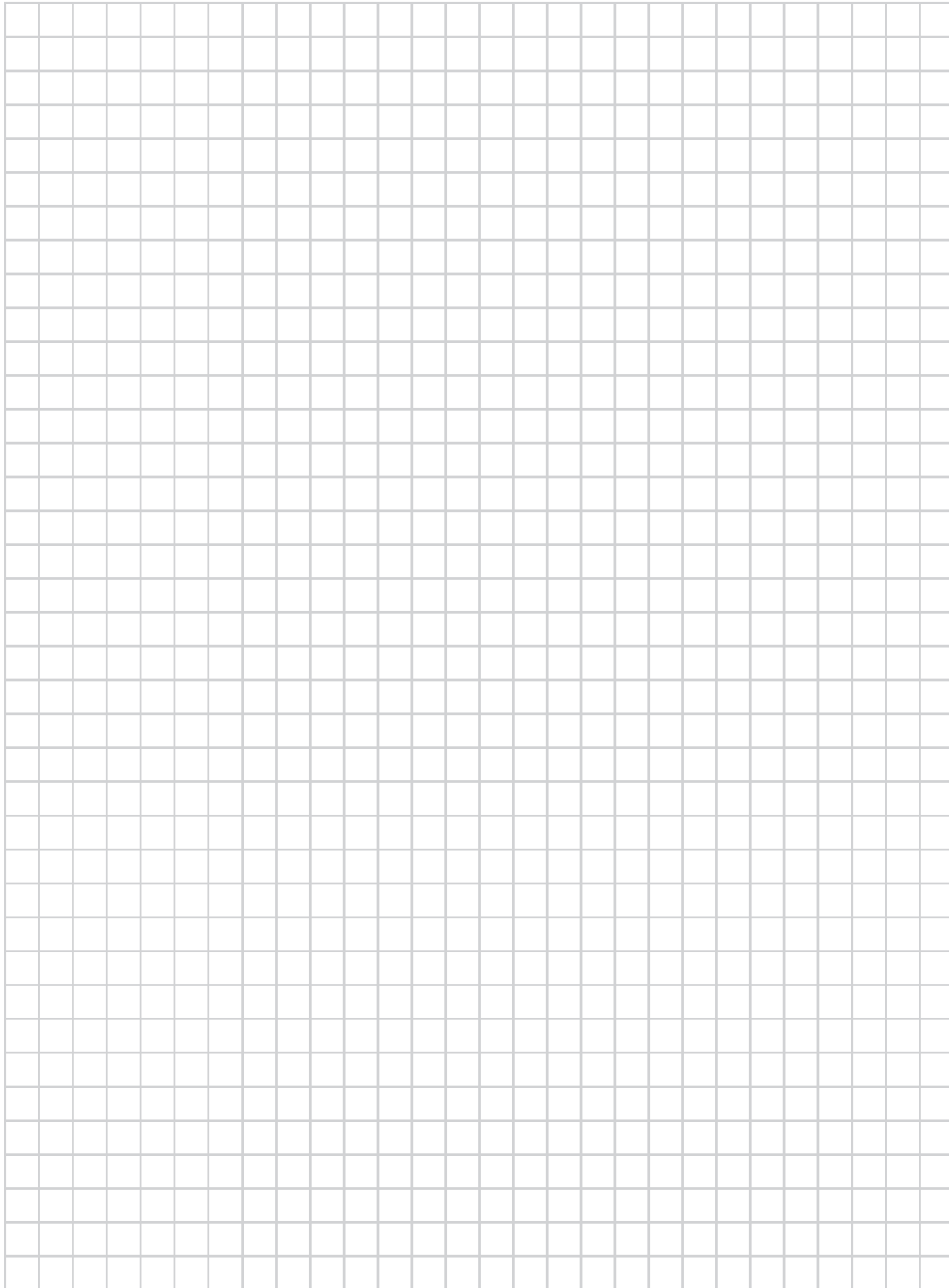

Each square represents 10 mm



(d) Tracing paper was used to design the prototype play cube.

Explain **one** reason why designers use tracing paper.

(2)

.....

.....

.....

**(Total for Question 2 = 9 marks)**

DO NOT WRITE IN THIS AREA

DO NOT WRITE IN THIS AREA

DO NOT WRITE IN THIS AREA



DO NOT WRITE IN THIS AREA

DO NOT WRITE IN THIS AREA

DO NOT WRITE IN THIS AREA

3 Figure 4 shows part of a solar powered garden light.

The outer case is made from acrylic.

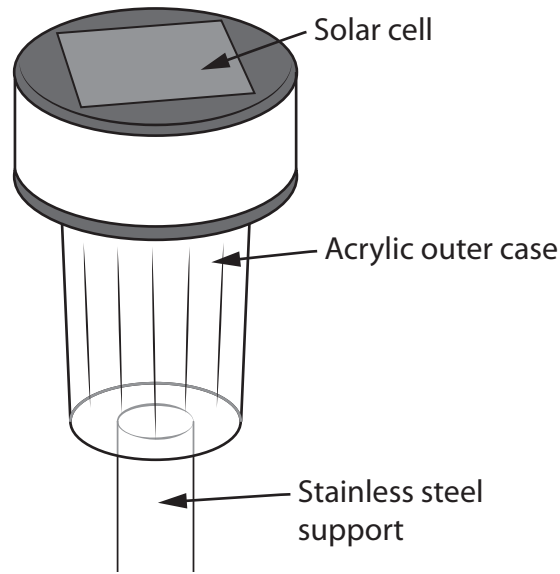

Figure 4

(a) Give **one** property of acrylic that makes it an appropriate material from which to make the outer case.

(1)

(b) The solar powered garden light is held off the ground by a stainless steel support.

Explain **one** reason for using stainless steel for the support.

(2)

(c) The manufacturer of the solar powered garden light wants to reduce its carbon footprint.

Explain **one** way new and emerging technologies could be used to reduce the manufacturer's carbon footprint.

(2)



(d) The solar cell used in the solar powered garden light costs  $\frac{1}{12}$ th of the total cost of the product.

Calculate the cost of the solar cell if each light costs £4.97 to make.

Give your answer to two significant figures.

(2)

£ .....

(e) The manufacturer of the solar powered garden light employs different groups of people including apprentices.

Explain **two** ways that the use of new and emerging technologies could affect the apprentices.

(4)

1 .....

.....

.....

2 .....

.....

.....

**(Total for Question 3 = 11 marks)**





DO NOT WRITE IN THIS AREA

DO NOT WRITE IN THIS AREA

DO NOT WRITE IN THIS AREA

4 Figure 5 shows a drawing of a jewellery box made from mahogany.

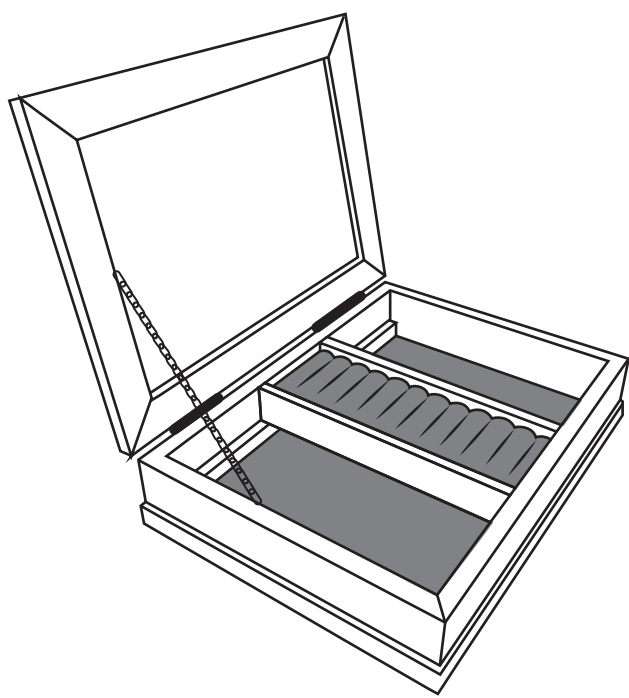

Figure 5

The electronic component shown in Figure 6 is used in the jewellery box.

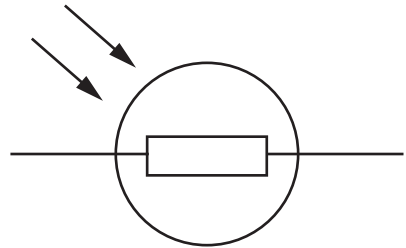

Figure 6

(a) (i) Name the electronic component shown in Figure 6.

(1)



- (ii) The jewellery box uses a programmable component to turn on a musical tune when the lid is opened, that stays on until the lid is closed.

Figure 7 shows a partly completed flowchart for the programmable component.

Correctly label the **decision outputs** and add the remaining **lines** and **arrows** on the flowchart to show how the programmable component:

- turns on the musical tune when the lid is opened
- turns off the musical tune when the lid is closed.

(3)

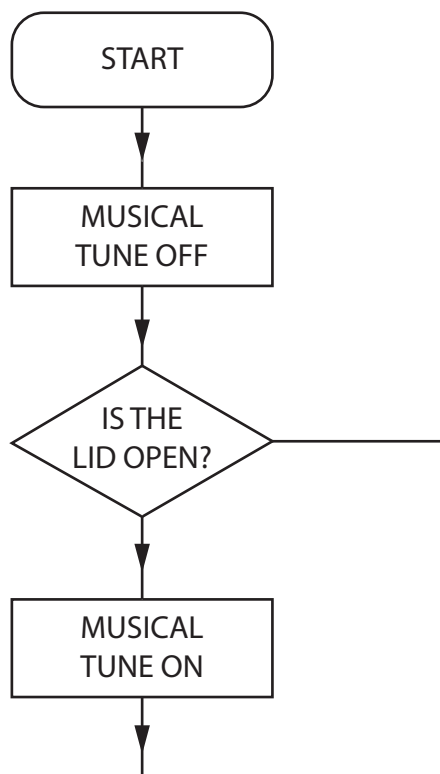

Figure 7



(b) Analyse the information in Figure 8 about the sources of mahogany.

Sources of mahogany	Percentage grown in each area (%)
Native forests	7
National parks	30
Other	63

**Figure 8**

Complete the bar chart below to show the percentage grown in each area.

The first one has been done for you.

(2)

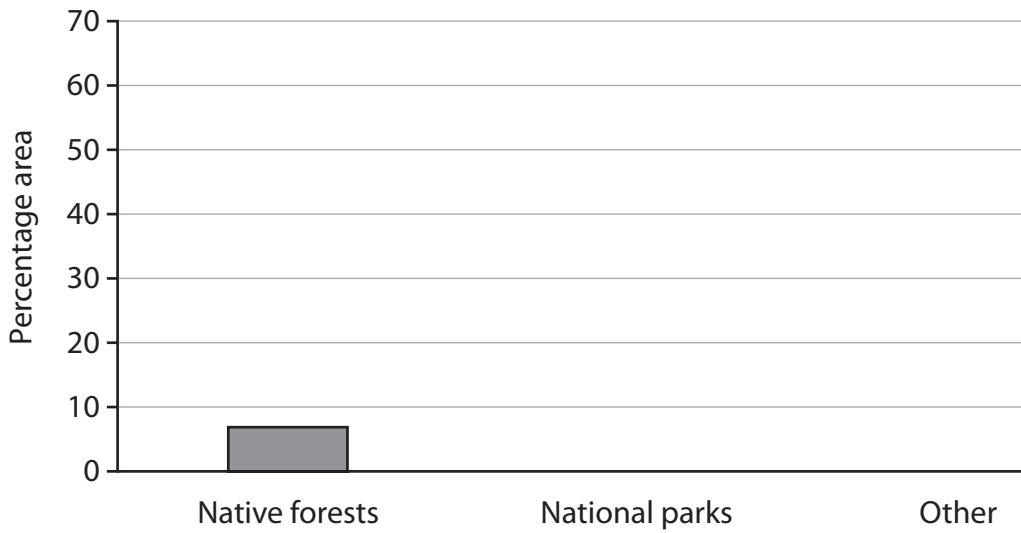

DO NOT WRITE IN THIS AREA



DO NOT WRITE IN THIS AREA

DO NOT WRITE IN THIS AREA

DO NOT WRITE IN THIS AREA

(c) A film company is considering launching a range of musical jewellery boxes based on its animated characters.

Discuss the different design strategies the company could use to generate initial ideas and to avoid design fixation.

(6)

Area with horizontal dotted lines for writing.



DO NOT WRITE IN THIS AREA

DO NOT WRITE IN THIS AREA

DO NOT WRITE IN THIS AREA

Handwriting practice area with 15 horizontal dotted lines.

(Total for Question 4 = 12 marks)

**TOTAL FOR SECTION A = 40 MARKS**



P 5 9 6 6 6 A 0 1 3 2 8

## SECTION B – TEXTILES

Answer ALL questions. Write your answers in the spaces provided.

- 5 Figure 9 shows a design solution for an armchair organiser together with some additional information.

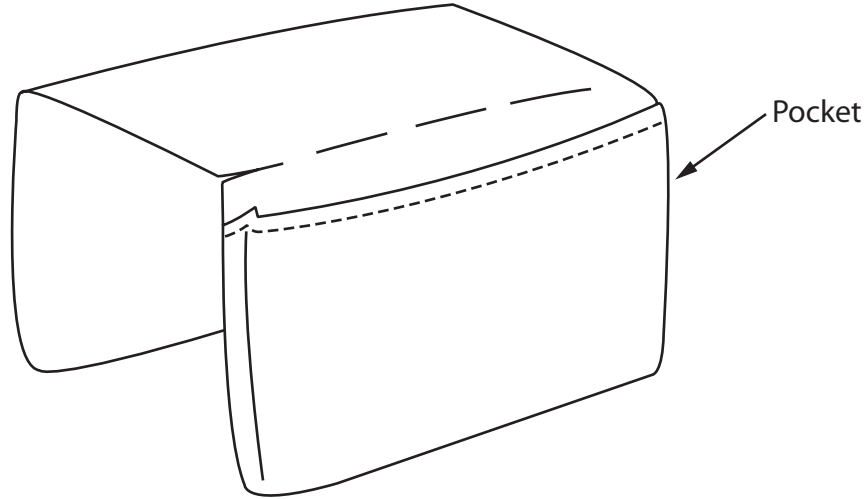

Additional information

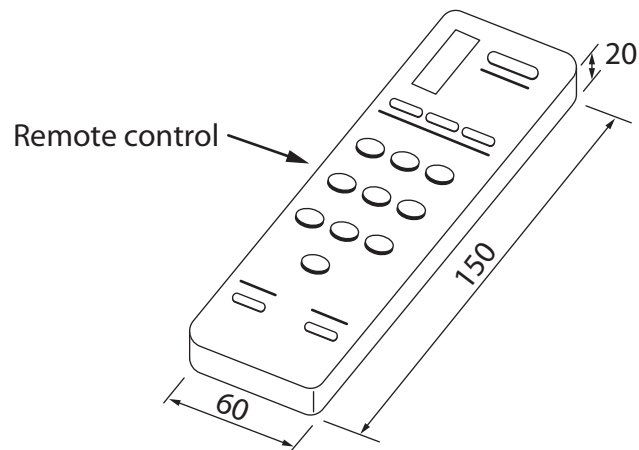

All dimensions in mm

Figure 9

DO NOT WRITE IN THIS AREA

DO NOT WRITE IN THIS AREA

DO NOT WRITE IN THIS AREA



- (a) The armchair organiser needs to be improved to include the following specification points.

The armchair organiser must:

- be able to be securely fitted to chair arms that are 200 mm to 240 mm wide
- provide a method to hold a coffee cup without the risk of it being tipped over
- store two remote controls so they are both separate and cannot fall out of the organiser.

Use notes and sketches, on the outline below, to show how the armchair organiser could be modified to include these specification points.

You will be marked on how you apply your understanding of design and technology, not your graphical skills.

(6)

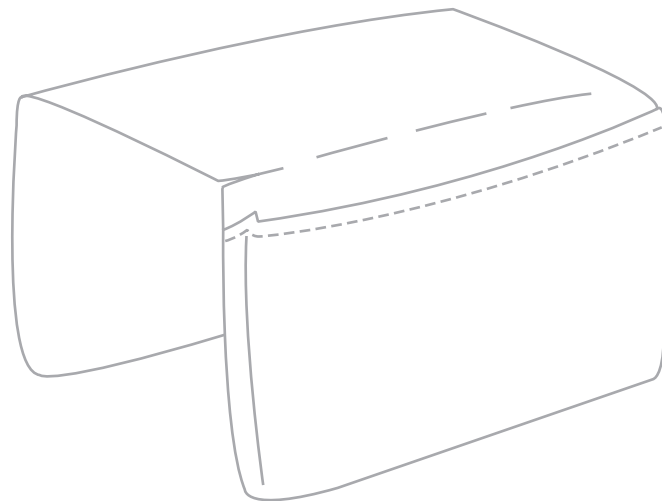





DO NOT WRITE IN THIS AREA

DO NOT WRITE IN THIS AREA

DO NOT WRITE IN THIS AREA

6 Figure 11 shows a book made from upcycled fabrics.



Figure 11

(a) Explain **two** advantages of manufacturing the book from upcycled fabrics.

(4)

1 .....

.....

.....

.....

.....

.....

2 .....

.....

.....

.....

.....



(b) Figure 12 shows two layers of fabric that will be used to construct a page for the book.

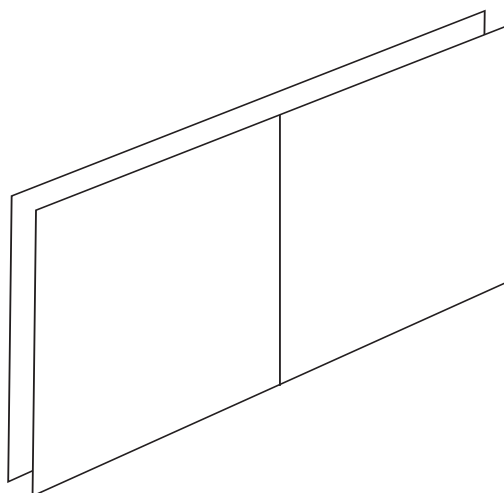

**Figure 12**

Use notes and sketches, in the space below, to show how the layers would be joined to make a page with no raw edges.

You will be marked on how you apply your understanding of design and technology, not your graphical skills.

(4)

Blank space for student response.



(c) Figure 13 shows the inside of the book. It has been decorated with different features.

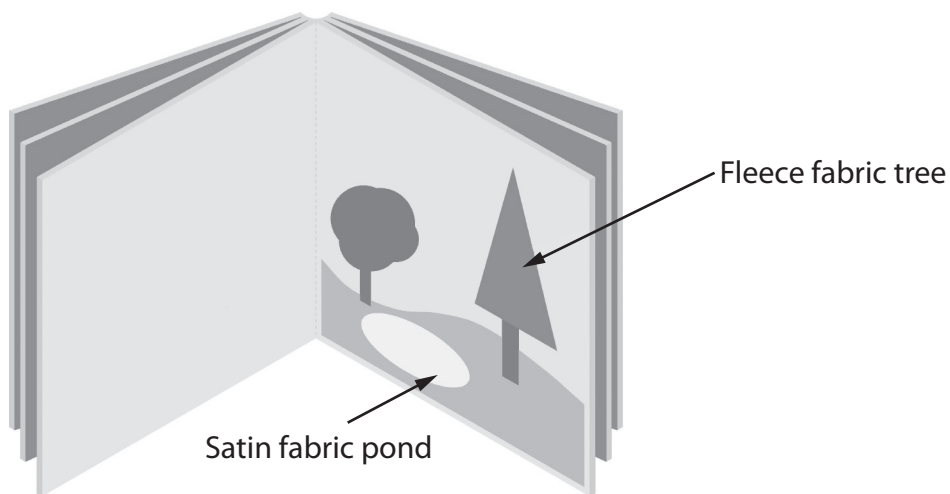

**Figure 13**

Explain **one** reason for using different fabrics for the tree and the pond.

(2)

.....

.....

.....

.....

(d) Figure 14 shows the tree for the book.

The trees are to be manufactured from fleece fabric in a batch of 1000.

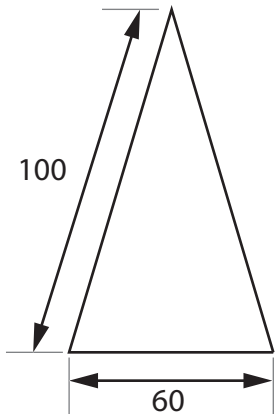

All dimensions in mm

**Figure 14**

Name **two** different techniques that could be used to batch produce the tree.

Explain **one** advantage of using each technique.

(6)

Technique 1

Explanation

Technique 2

Explanation

**(Total for Question 6 = 16 marks)**



7 Figure 15 shows some outdoor bunting that is made from a woven nylon fabric.

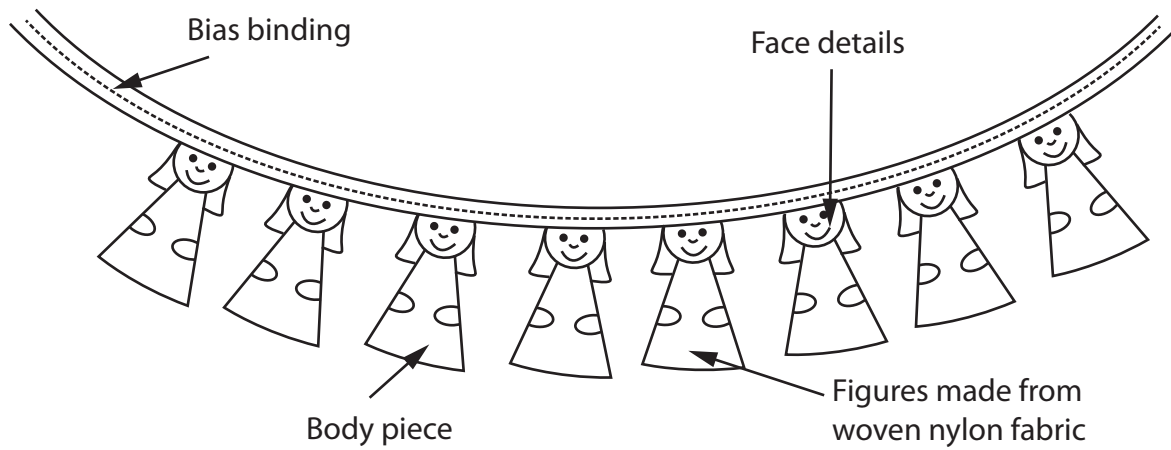

**Figure 15**

(a) Name **one** surface finish or surface treatment that could be used to apply the detail to each face.

(1)

(b) The figures are attached to stock-sized 25 mm wide bias binding.

Explain **two** reasons for using stock-sized bias binding.

(4)

1 .....

.....

.....

.....

2 .....

.....

.....

.....



(c) Figure 16 shows the dimensions for the body of the bunting figures.

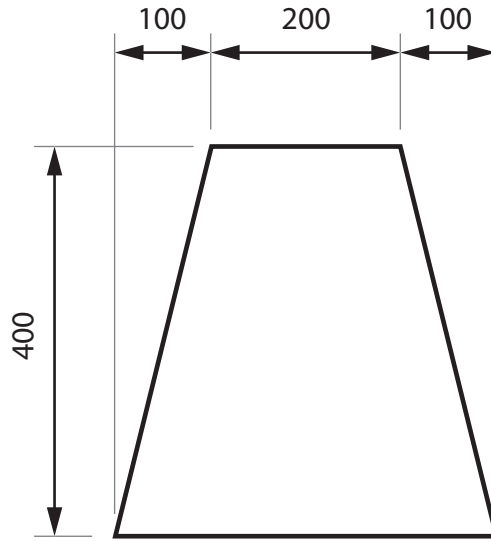

All dimensions in mm

Diagram not to scale

**Figure 16**

DO NOT WRITE IN THIS AREA

DO NOT WRITE IN THIS AREA

DO NOT WRITE IN THIS AREA



Calculate the maximum number of whole bunting figure bodies that could be cut from a length of fabric measuring 1810 cm long by 40 cm wide.

Ignore the width of any cuts.

(5)

Answer ..... whole bodies

DO NOT WRITE IN THIS AREA

DO NOT WRITE IN THIS AREA

DO NOT WRITE IN THIS AREA



P 5 9 6 6 6 A 0 2 3 2 8

(d) Explain **two** properties of woven nylon fabric that make it an appropriate choice of material for the figures on the outdoor bunting.

(6)

1 .....

.....

.....

.....

.....

.....

2 .....

.....

.....

.....

.....

.....

**(Total for Question 7 = 16 marks)**

DO NOT WRITE IN THIS AREA

DO NOT WRITE IN THIS AREA

DO NOT WRITE IN THIS AREA





DO NOT WRITE IN THIS AREA

DO NOT WRITE IN THIS AREA

DO NOT WRITE IN THIS AREA

8 Figure 17 shows a kitchen apron made from a woven twill cotton fabric.



Figure 17

(a) (i) Explain **one** reason for applying a fireproofing treatment to the kitchen apron. (2)

.....

.....

.....

.....

(ii) Explain **one** working property of a woven twill fabric that makes it suitable for the kitchen apron. (3)

.....

.....

.....

.....

.....



DO NOT WRITE IN THIS AREA

DO NOT WRITE IN THIS AREA

DO NOT WRITE IN THIS AREA

(b) The apron is also dyed.

Explain **two** negative effects on the environment of dyeing cotton.

(4)

1 .....

.....

.....

.....

2 .....

.....

.....

.....





DO NOT WRITE IN THIS AREA

DO NOT WRITE IN THIS AREA

DO NOT WRITE IN THIS AREA

(Total for Question 8 = 18 marks)

**TOTAL FOR SECTION B = 60 MARKS**

**TOTAL FOR PAPER = 100 MARKS**

