

Write your name here

Surname

Other names

Pearson Edexcel
Level 3 GCE

Centre Number

--	--	--	--	--	--

Candidate Number

--	--	--	--	--

Physics

Advanced Subsidiary
Paper 1: Core Physics I

Tuesday 15 May 2018 – Morning
Time: 1 hour 30 minutes

Paper Reference

8PH0/01

You must have:

Ruler and protractor

Total Marks

--

Instructions

- Use **black** ink or ball-point pen.
- **Fill in the boxes** at the top of this page with your name, centre number and candidate number.
- Answer **all** questions in Sections A and B.
- Answer the questions in the spaces provided – *there may be more space than you need.*

Information

- The total mark for this paper is 80.
- The marks for **each** question are shown in brackets – *use this as a guide as to how much time to spend on each question.*
- You may use a scientific calculator.
- In questions marked with an **asterisk** (*), marks will be awarded for your ability to structure your answer logically, showing how the points that you make are related or how they follow on from each other where appropriate.

Advice

- Read each question carefully before you start to answer it.
- Try to answer every question.
- Check your answers if you have time at the end.
- You are advised to show your working in calculations, including units where appropriate.

Turn over ►

P51576A

©2018 Pearson Education Ltd.

1/1/1/1/1/1/



Pearson

SECTION A

Answer ALL questions.

All multiple choice questions must be answered with a cross in the box for the correct answer from A to D. If you change your mind about an answer, put a line through the box and then mark your new answer with a cross .

1 All quantities may be expressed in terms of SI base units.

Select the row of the table that states the SI base units for the given quantity.

	Quantity	SI base unit
<input type="checkbox"/> A	charge	C
<input type="checkbox"/> B	charge	A s ⁻¹
<input type="checkbox"/> C	power	J s ⁻¹
<input type="checkbox"/> D	power	kg m ² s ⁻³

(Total for Question 1 = 1 mark)

DO NOT WRITE IN THIS AREA

DO NOT WRITE IN THIS AREA

DO NOT WRITE IN THIS AREA



DO NOT WRITE IN THIS AREA

DO NOT WRITE IN THIS AREA

DO NOT WRITE IN THIS AREA

2 Two balls, X and Y, are kicked across a football pitch.

Ball X is kicked at an angle of θ to the horizontal, where θ is greater than 45° .

The trajectory for the motion of ball X is shown.



Ball Y is kicked with the same speed at an angle greater than θ to the horizontal.

Which diagram correctly shows the trajectory of ball Y?

----- Ball X

————— Ball Y

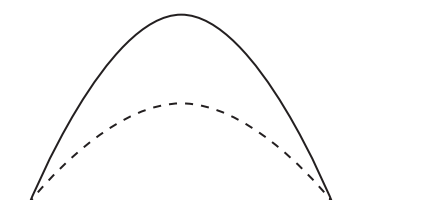

A

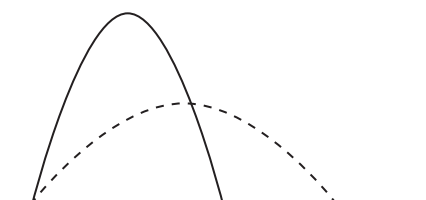

B

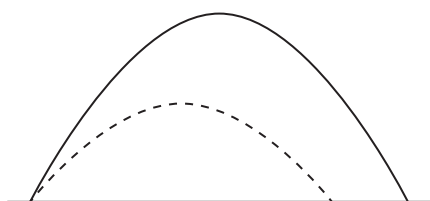

C

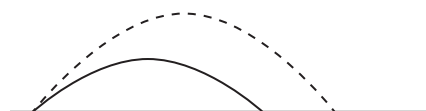

D

- A
- B
- C
- D

(Total for Question 2 = 1 mark)



3 Which of the following increases as the temperature of a metallic conductor increases?

- A amplitude of the vibrations of the lattice ions
- B distance travelled by the charge carriers between collisions
- C drift velocity of the conduction electrons
- D number of conduction electrons per unit volume

(Total for Question 3 = 1 mark)

4 The graph shows how the potential difference V varies with the current I for a circuit component.

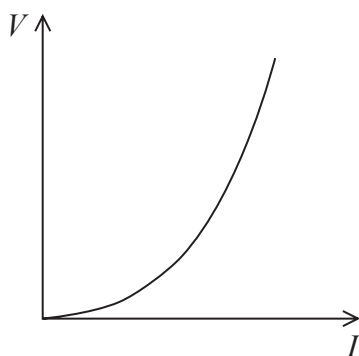

Which of the following could be the circuit component?

- A diode
- B filament bulb
- C ohmic resistor
- D thermistor

(Total for Question 4 = 1 mark)



DO NOT WRITE IN THIS AREA

DO NOT WRITE IN THIS AREA

DO NOT WRITE IN THIS AREA

- 5 A student carried out an experiment to determine the acceleration of free fall. The initial height of a ball bearing was measured using a metre rule.

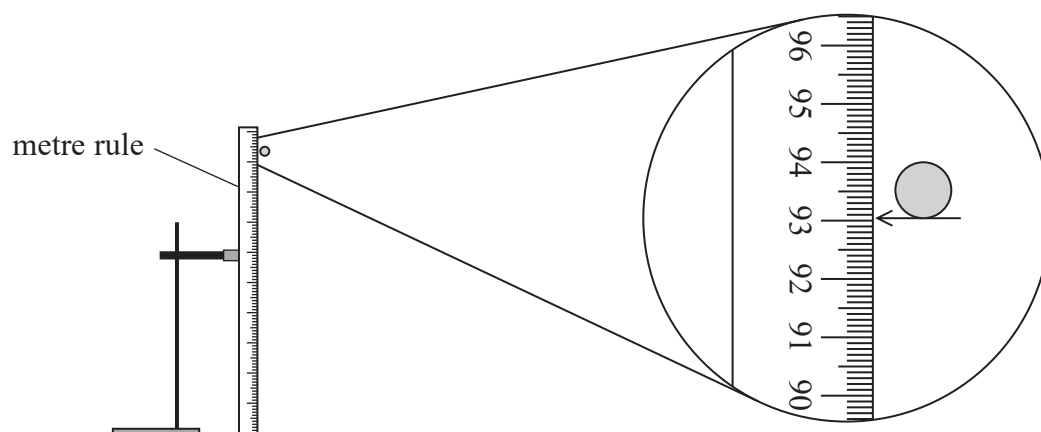

What is the best estimate of the percentage uncertainty in the measurement of height?

- A $\pm 0.001\%$
- B $\pm 0.01\%$
- C $\pm 0.1\%$
- D $\pm 1\%$

(Total for Question 5 = 1 mark)

- 6 A car of mass $1.2 \times 10^3 \text{ kg}$ is travelling at a speed of 18 ms^{-1} . The driver applies the brakes and the car comes to rest.

What is the work done by the brakes in stopping the car?

- A 11 kJ
- B 22 kJ
- C 190 kJ
- D 390 kJ

(Total for Question 6 = 1 mark)



- 7 A student carried out an experiment to determine the electromotive force (e.m.f.) of a cell. The current in a circuit was changed by adjusting a variable resistor. A graph was plotted of the voltmeter reading on the y-axis against the ammeter reading on the x-axis.

Using the data obtained, the value of the intercept on the y-axis was the e.m.f. of the cell.

Which of the following circuits should have been used?

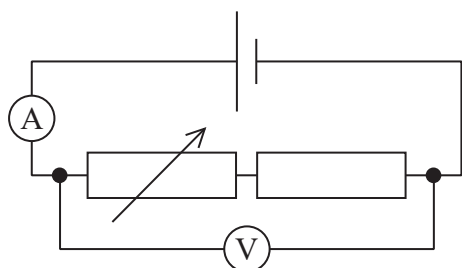

A

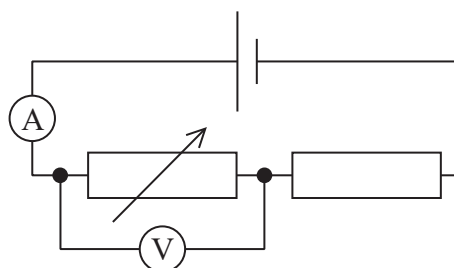

B

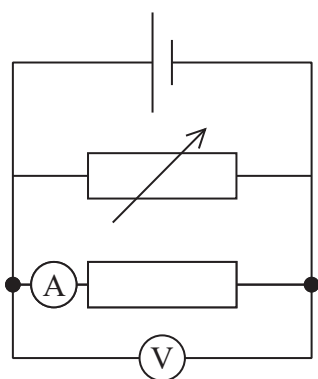

C

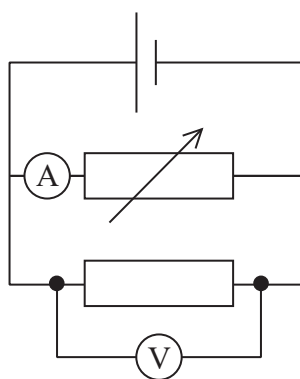

D

- A
- B
- C
- D

(Total for Question 7 = 1 mark)



DO NOT WRITE IN THIS AREA

DO NOT WRITE IN THIS AREA

DO NOT WRITE IN THIS AREA

8 An athlete runs a race around three quarters of a circular track of radius 30 m using the inside lane.

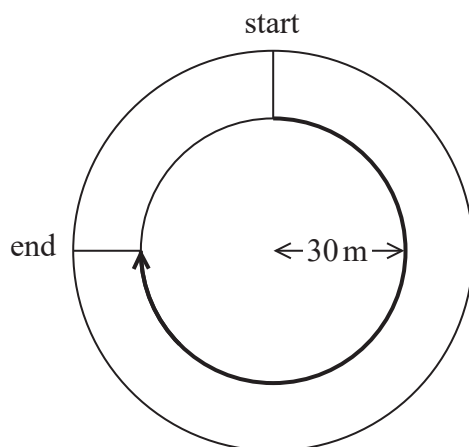

What is the magnitude of the displacement of the athlete at the end of the race?

- A 141 m
- B 47 m
- C 42 m
- D 30 m

(Total for Question 8 = 1 mark)



- 9 (a) Three resistors, of resistance R_1 , R_2 and R_3 , are connected in series across a cell. The cell has electromotive force (e.m.f.) \mathcal{E} with negligible internal resistance. The current through the cell is I .

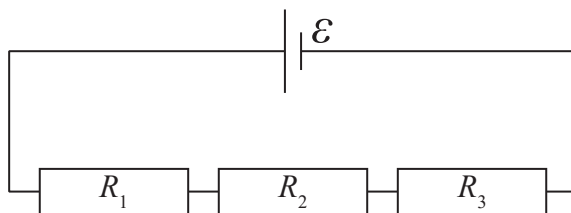

Derive the formula for the total resistance R_T of the circuit in terms of R_1 , R_2 and R_3 . (3)

.....

.....

.....

.....

.....

.....

DO NOT WRITE IN THIS AREA

DO NOT WRITE IN THIS AREA

DO NOT WRITE IN THIS AREA



DO NOT WRITE IN THIS AREA

DO NOT WRITE IN THIS AREA

DO NOT WRITE IN THIS AREA

(b) The circuit diagram shows two resistors in series across a battery of e.m.f. 6.0 V and negligible internal resistance. A voltmeter with low resistance is connected across the 40 Ω resistor.

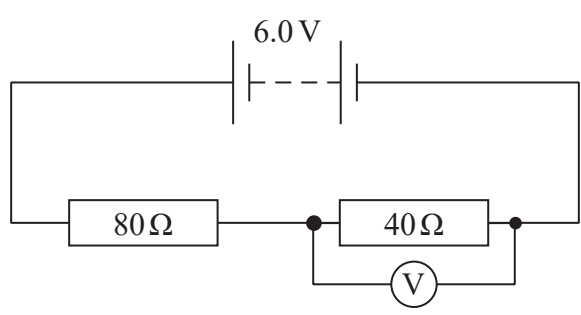

The reading on the voltmeter is 1.8 V.

Calculate the resistance of the voltmeter.

(3)

.....

.....

.....

.....

.....

.....

.....

Resistance of voltmeter =

(Total for Question 9 = 6 marks)



10 A thin wire of negligible mass is used to hang a picture on a wall. The wire is hung over a nail and can be attached to the picture using arrangement 1 or arrangement 2, as shown.

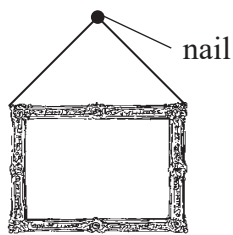

arrangement 1

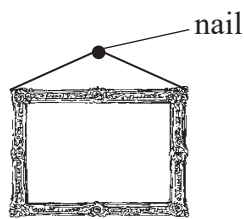

arrangement 2

(a) Deduce which wire arrangement should be used to keep the tension in the wire as small as possible.

(4)

.....

.....

.....

.....

.....

.....

.....

.....

.....

DO NOT WRITE IN THIS AREA

DO NOT WRITE IN THIS AREA

DO NOT WRITE IN THIS AREA



(b) It was observed that if the wire was not hung with its midpoint over the nail, as in Diagram 1, the picture moved and then remained in the position shown in Diagram 2.

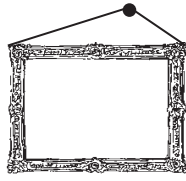

Diagram 1



Diagram 2

Use the idea of moments to explain why.

(3)

.....

.....

.....

.....

.....

.....

.....

(Total for Question 10 = 7 marks)



11 A fairground game requires the player to catapult a ball towards a target to score points.

The ball is required to reach a target a horizontal distance of 50 m away, at the same vertical height, as shown.

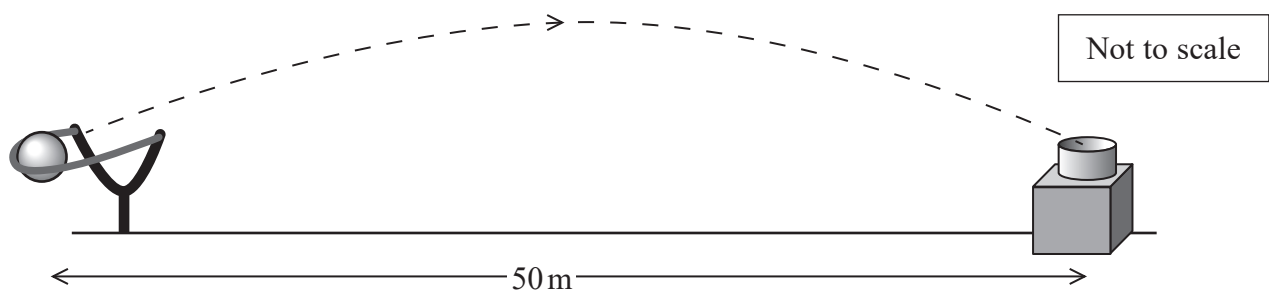

(a) The time taken for the ball to reach the target is 2.0 s.

Calculate the angle to the horizontal at which the ball is launched.

(4)

.....

.....

.....

.....

.....

.....

.....

.....

.....

.....

.....

Angle to the horizontal =



DO NOT WRITE IN THIS AREA

DO NOT WRITE IN THIS AREA

DO NOT WRITE IN THIS AREA

(b) During another launch, the catapult exerts a force on the ball of 9.0 N at 40° to the horizontal at the time of release.

Draw a labelled vector diagram to determine the resultant force acting on the ball at the time of release.

(4)

weight of ball = 2.0 N

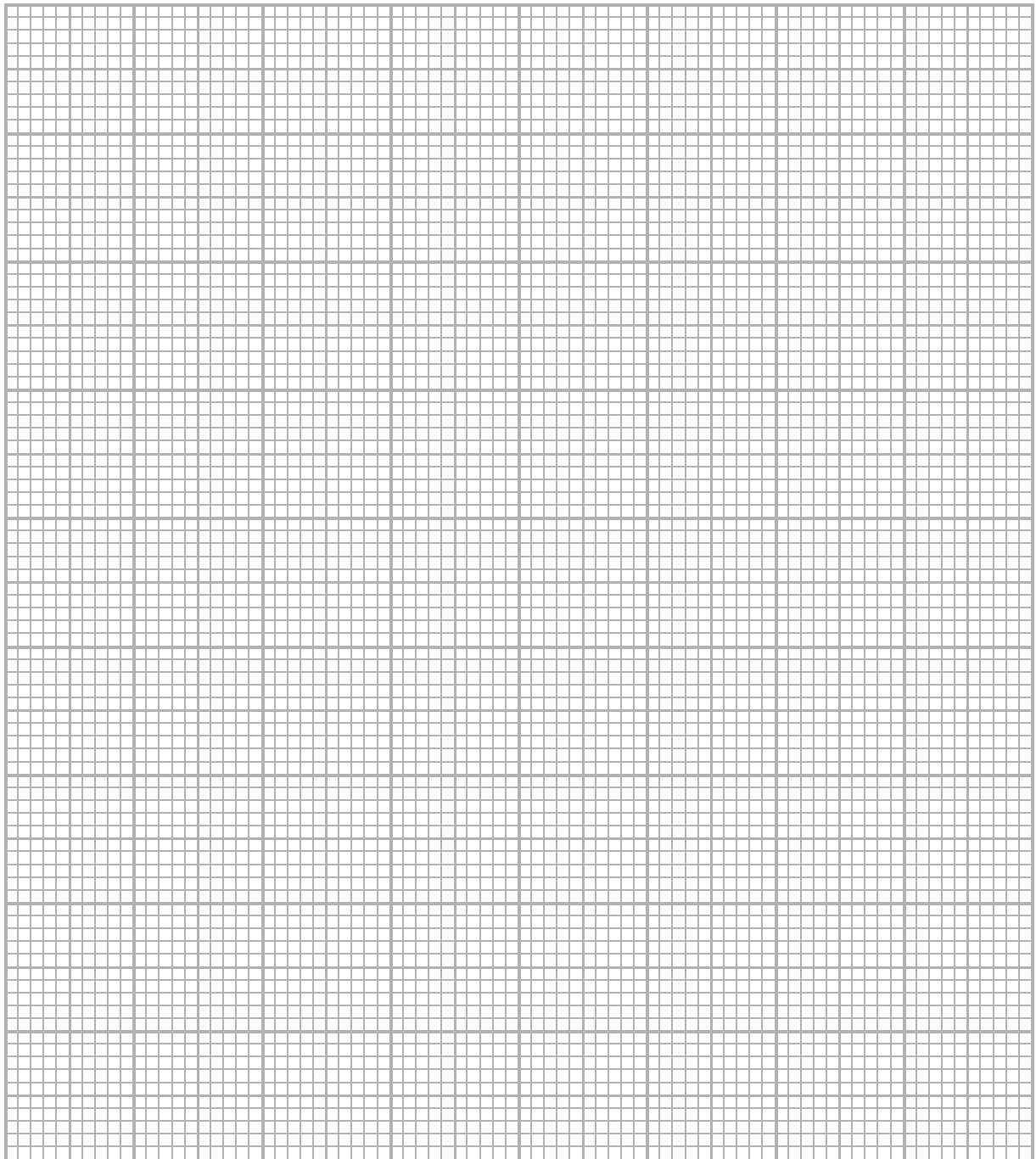

Magnitude of resultant force =

Angle of resultant force to the horizontal =

(Total for Question 11 = 8 marks)



P 5 1 5 7 6 A 0 1 3 3 2

- 12 A teacher uses a linear air track to provide a frictionless surface for two gliders, each of mass m . She uses this, with a pair of light gates connected to a computer, to investigate a collision between the gliders.

The gliders are each given a small push and travel towards the centre of the track. The gliders collide and move off together.

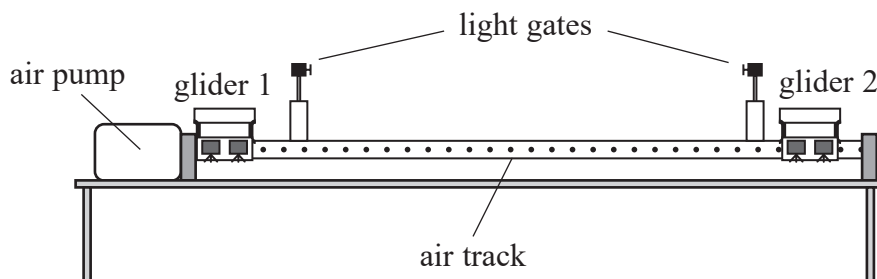

- (a) The computer displays the velocity of the gliders as they pass through the light gates.

Calculate the velocity of the gliders after the collision, using the principle of conservation of linear momentum.

(3)

initial velocity of glider 1 = 0.30 m s^{-1} to the right

initial velocity of glider 2 = 0.70 m s^{-1} to the left

.....

.....

.....

.....

.....

.....

Magnitude of velocity =

Direction of velocity =



DO NOT WRITE IN THIS AREA

DO NOT WRITE IN THIS AREA

DO NOT WRITE IN THIS AREA

(b) The teacher asked a student to justify the change in velocity of glider 1 using Newton's laws of motion.

The student began his explanation with the statement:

"During the collision there is a force on glider 2"

Complete the explanation to justify the change in velocity of glider 1, making reference to Newton's laws of motion where appropriate.

(4)

.....

.....

.....

.....

.....

.....

.....

.....

.....

.....

.....

.....

.....

.....

.....

.....

.....

.....

.....

.....

.....

.....

.....

(Total for Question 12 = 7 marks)



13 Archaeologists use resistivity surveying of soil to search for the remains of buildings and settlements under the ground.

A basic arrangement that can be used to determine the resistivity of a region of soil is shown.

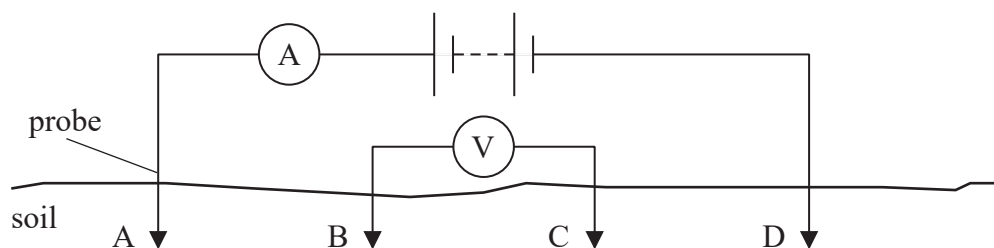

Probes are placed at positions A and D so that the length AD of soil forms part of the circuit. The ammeter measures the current through the soil.

A second pair of probes connected to a voltmeter is placed at positions B and C. This measures the potential difference between positions B and C in the soil.

(a) Explain how the reading on the voltmeter will change if the length BC increases.

(2)

.....

.....

.....

.....

.....



(b) The table gives the resistivity of some different materials.

Material	Resistivity / $\Omega \text{ m}$
Undisturbed clay	4–20
Compacted clay	100–200
Limestone	500–1000
Sandstone	1500–10 000

The probes connected to the voltmeter are kept at a constant separation of 0.75 m and are moved along the soil between positions A and D.

The current is constant at 9.5 mA. The voltmeter reading varies between 1.8 V and 8.0 V.

It can be assumed that the sample of soil under investigation has a cross-sectional area of 0.65 m^2 .

Deduce two possible materials that could be present in the soil between positions A and D.

(4)

(Total for Question 13 = 6 marks)



14 The world land speed record of 341 m s^{-1} was set in October 1997. In an attempt to break this record, a new supersonic car has been developed called the Bloodhound.



The developers of the Bloodhound have used computer modelling to produce a velocity-time graph for the predicted motion of the car, on a straight track, during the record attempt.

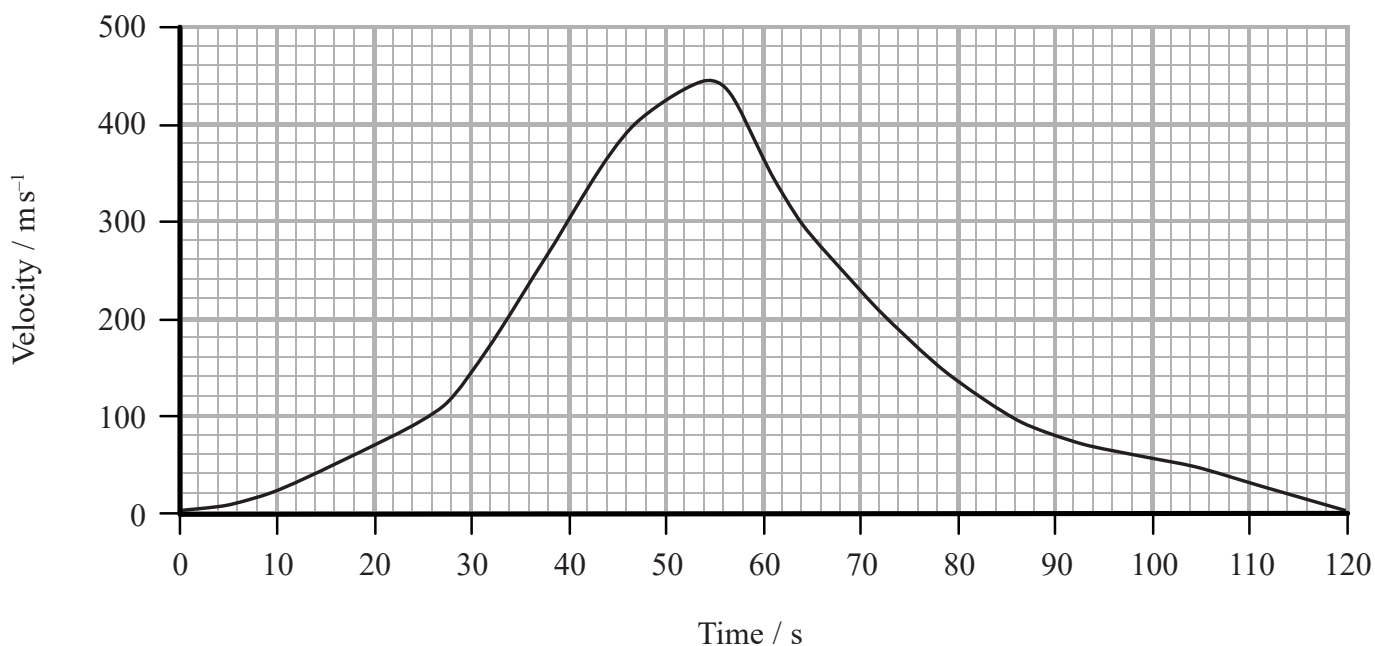

(a) A track of length 23 km is available for the record attempt.

Determine whether this track is long enough.

(3)

.....

.....

.....

.....

.....

.....



(b) The car has two different engines: a jet engine providing a thrust of 89 kN and a rocket engine providing a thrust of 120 kN.

(i) The jet engine runs throughout the car's acceleration stage. The rocket engine runs for only part of that stage.

State the time at which the rocket engine is started during the car's predicted motion.

(1)

(ii) Use the graph to determine the maximum positive acceleration of the car.

(2)

Maximum positive acceleration of the car =

(iii) Calculate a value for the frictional force acting on the car when the positive acceleration is a maximum.

(3)

mass of car including fuel at this time = 7790 kg

Frictional force during maximum positive acceleration =



***(c)** Discuss, with reference to the graph, the factors that would have been used to predict the motion of the car over the 120 s.

(6)

DO NOT WRITE IN THIS AREA

DO NOT WRITE IN THIS AREA

DO NOT WRITE IN THIS AREA

(Total for Question 14 = 15 marks)

TOTAL FOR SECTION A = 57 MARKS



DO NOT WRITE IN THIS AREA

DO NOT WRITE IN THIS AREA

DO NOT WRITE IN THIS AREA

BLANK PAGE



P 5 1 5 7 6 A 0 2 1 3 2

SECTION B

Answer ALL questions.

- 15 A student carried out an experiment to determine the speed of sound in air. A short pulse of sound was produced by bursting a balloon near two microphones. The microphones were placed 1.00 m apart and connected to a computer.

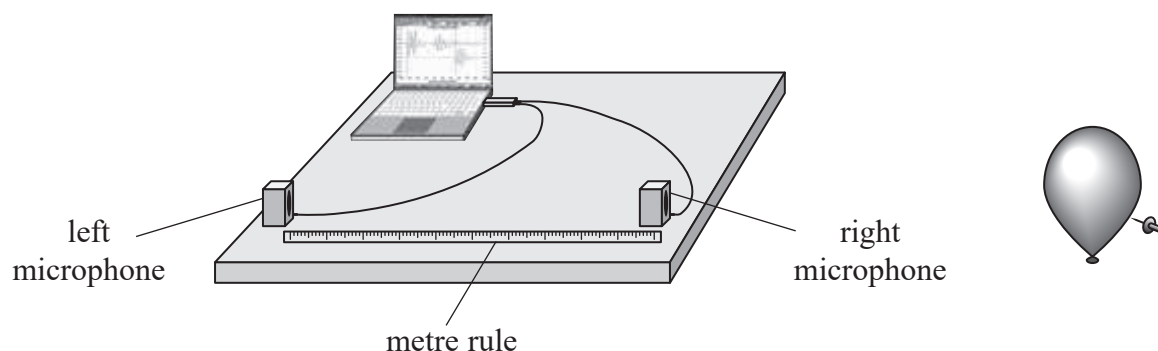

The computer was used to determine the time interval between the sound wave being received at the right microphone and being received at the left microphone.

The separation of the microphones was decreased several times and the corresponding time intervals recorded. The student obtained the following results.

Microphone separation / m	Time interval / ms
1.00	3.2
0.90	2.8
0.80	2.4
0.70	2.1
0.60	1.9
0.50	1.5

- (a) Criticise these results.

(1)

- (b) (i) Plot a graph of microphone separation against time interval.

(4)

DO NOT WRITE IN THIS AREA

DO NOT WRITE IN THIS AREA

DO NOT WRITE IN THIS AREA



DO NOT WRITE IN THIS AREA

DO NOT WRITE IN THIS AREA

DO NOT WRITE IN THIS AREA

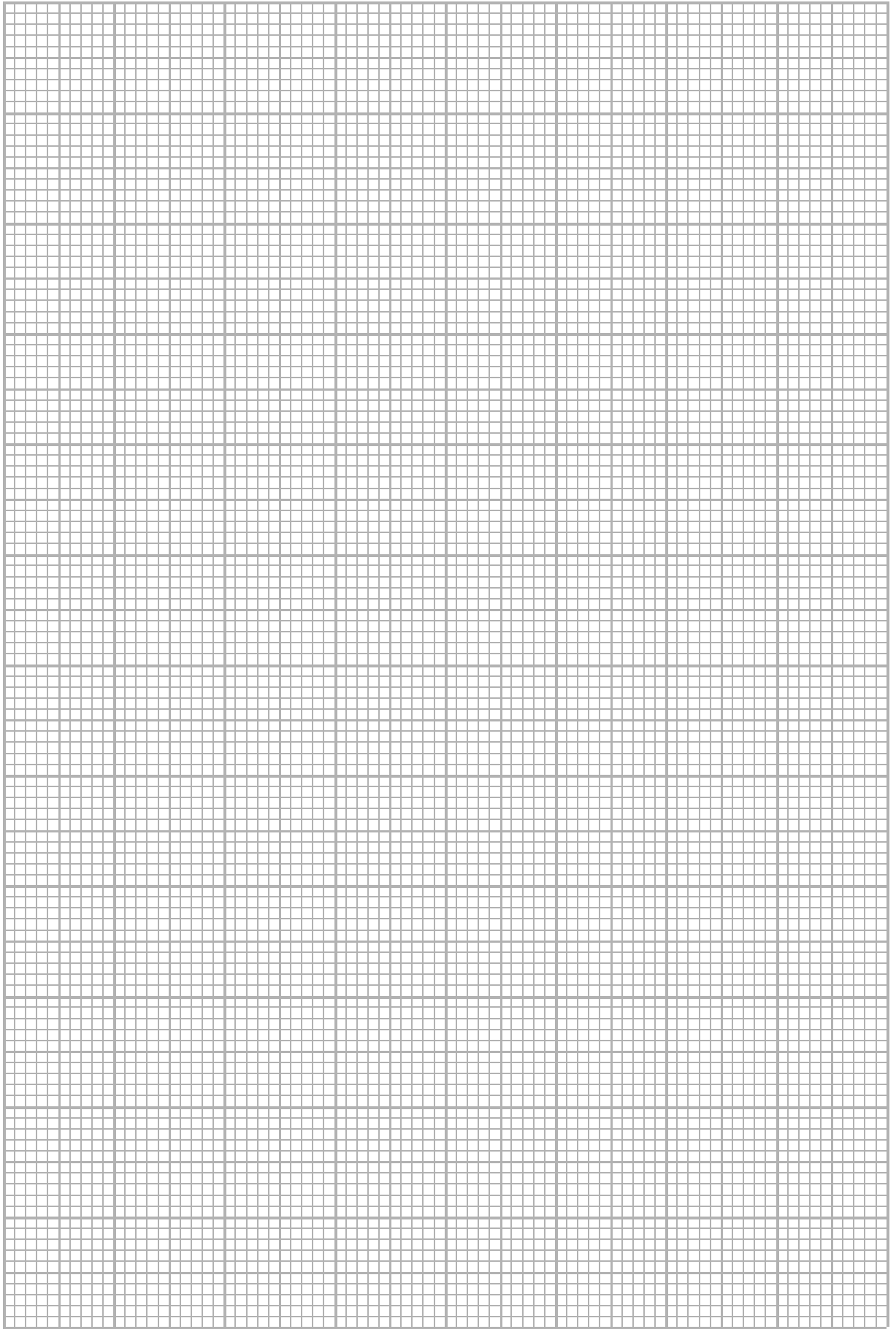

(ii) Determine a value for the speed of sound in air.

(2)

.....
.....
.....

Speed of sound in air =

(c) The actual speed of sound in air is 330 m s^{-1} .

Comment on the value for the speed of sound in air at this temperature obtained from the student's results, referring to any possible sources of error.

(3)

.....
.....
.....
.....
.....
.....
.....
.....
.....
.....

(Total for Question 15 = 10 marks)

DO NOT WRITE IN THIS AREA

DO NOT WRITE IN THIS AREA

DO NOT WRITE IN THIS AREA



16 A liquid-crystal display uses a series of segments to form letters and numbers on a screen.

(a) The construction of a display segment is shown.

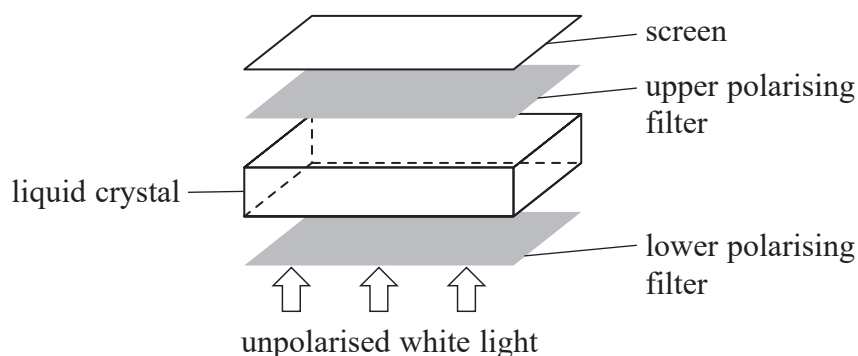

- Unpolarised white light passes through the lower polarising filter and becomes plane polarised.
- When there is no potential difference (p.d.) across the liquid crystal, the molecules in the liquid crystal rotate the plane of polarisation by 90° .
- Light then passes through the upper polarising filter and appears on the screen.
- When a p.d. is applied across the liquid crystal, the molecules no longer rotate the plane of polarisation. The light will not pass through the upper polarising filter and the screen appears dark.

(i) Describe what is meant by plane polarised light.

(2)

.....

.....

.....

.....

.....

.....

.....

(ii) Explain the angle of polarisation of the upper polarising filter relative to the lower polarising filter.

(2)

.....

.....

.....

.....

.....



- (b) (i) The intensity of the emitted light at the surface of a display segment is 7.8 W m^{-2} .
The segment has an exposed area of $1.8 \times 10^{-3} \text{ m}^2$.

Calculate the power of the emitted light at the surface of the display segment.

(2)

.....
.....
.....
.....

Power of emitted light =

- (ii) A light-emitting diode (LED) is used to provide the unpolarised white light for the liquid-crystal display.

Calculate the efficiency of the liquid-crystal display segment.

(3)

current in LED = 20 mA

p.d. across LED = 3.6 V

.....
.....
.....
.....
.....

Efficiency of liquid-crystal display segment =



(c) Manufacturers are developing new materials for flexible screens for liquid-crystal displays. The graph shows how stress varies with strain for two materials X and Y up to typical stresses that would be applied to the screens in normal use. Both materials behave elastically over the ranges shown.

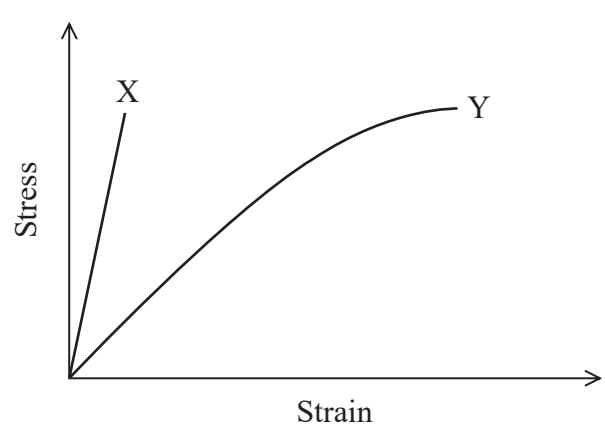

Deduce which material would be more suitable to use for the flexible screen in liquid-crystal displays.

(4)

.....

.....

.....

.....

.....

.....

.....

.....

.....

.....

.....

.....

.....

.....

.....

.....

.....

.....

.....

.....

.....

.....

(Total for Question 16 = 13 marks)

TOTAL FOR SECTION B = 23 MARKS
TOTAL FOR PAPER = 80 MARKS

Every effort has been made to contact copyright holders to obtain their permission for the use of copyright material. Pearson Education Ltd. will, if notified, be happy to rectify any errors or omissions and include any such rectifications in future editions.

DO NOT WRITE IN THIS AREA

DO NOT WRITE IN THIS AREA

DO NOT WRITE IN THIS AREA

BLANK PAGE



DO NOT WRITE IN THIS AREA

DO NOT WRITE IN THIS AREA

DO NOT WRITE IN THIS AREA

BLANK PAGE



P 5 1 5 7 6 A 0 2 9 3 2

DO NOT WRITE IN THIS AREA

DO NOT WRITE IN THIS AREA

DO NOT WRITE IN THIS AREA

BLANK PAGE



List of data, formulae and relationships

Acceleration of free fall	$g = 9.81 \text{ m s}^{-2}$	(close to Earth's surface)
Electron charge	$e = -1.60 \times 10^{-19} \text{ C}$	
Electron mass	$m_e = 9.11 \times 10^{-31} \text{ kg}$	
Electronvolt	$1 \text{ eV} = 1.60 \times 10^{-19} \text{ J}$	
Gravitational field strength	$g = 9.81 \text{ N kg}^{-1}$	(close to Earth's surface)
Planck constant	$h = 6.63 \times 10^{-34} \text{ J s}$	
Speed of light in a vacuum	$c = 3.00 \times 10^8 \text{ m s}^{-1}$	

Mechanics

Kinematic equations of motion

$$s = \frac{(u + v)t}{2}$$

$$v = u + at$$

$$s = ut + \frac{1}{2}at^2$$

$$v^2 = u^2 + 2as$$

Forces

$$\Sigma F = ma$$

$$g = \frac{F}{m}$$

$$W = mg$$

$$\text{moment of force} = Fx$$

Momentum

$$p = mv$$

Work, energy and power

$$\Delta W = F\Delta s$$

$$E_k = \frac{1}{2}mv^2$$

$$\Delta E_{\text{grav}} = mg\Delta h$$

$$P = \frac{E}{t}$$

$$P = \frac{W}{t}$$

$$\text{efficiency} = \frac{\text{useful energy output}}{\text{total energy input}}$$

$$\text{efficiency} = \frac{\text{useful power output}}{\text{total power input}}$$

Electric circuits

Potential difference

$$V = \frac{W}{Q}$$

Resistance

$$R = \frac{V}{I}$$

Electrical power and energy

$$P = VI$$

$$P = I^2R$$

$$P = \frac{V^2}{R}$$

$$W = VIt$$

Resistivity

$$R = \frac{\rho l}{A}$$

Current

$$I = \frac{\Delta Q}{\Delta t}$$

$$I = nqvA$$



Materials

Density

$$\rho = \frac{m}{V}$$

Stokes' law

$$F = 6\pi\eta r v$$

Hooke's law

$$F = k\Delta x$$

Pressure

$$p = \frac{F}{A}$$

Young modulus

$$\text{Stress } \sigma = \frac{F}{A}$$

$$\text{Strain } \varepsilon = \frac{\Delta x}{x}$$

$$E = \frac{\sigma}{\varepsilon}$$

Elastic strain energy

$$\Delta E_{\text{el}} = \frac{1}{2}F\Delta x$$

Waves and Particle Nature of Light

Wave speed

$$v = f\lambda$$

Speed of a transverse wave on a string

$$v = \sqrt{\frac{T}{\mu}}$$

Intensity of radiation

$$I = \frac{P}{A}$$

Power of a lens

$$P = \frac{1}{f}$$

$$P = P_1 + P_2 + P_3 + \dots$$

Thin lens equation

$$\frac{1}{u} + \frac{1}{v} = \frac{1}{f}$$

Magnification for a lens

$$m = \frac{\text{image height}}{\text{object height}} = \frac{v}{u}$$

Diffraction grating

$$n\lambda = d \sin \theta$$

Refractive index

$$n_1 \sin \theta_1 = n_2 \sin \theta_2$$

$$n = \frac{c}{v}$$

Critical angle

$$\sin C = \frac{1}{n}$$

Photon model

$$E = hf$$

Einstein's photoelectric equation

$$hf = \phi + \frac{1}{2}mv_{\text{max}}^2$$

de Broglie wavelength

$$\lambda = \frac{h}{p}$$

DO NOT WRITE IN THIS AREA

DO NOT WRITE IN THIS AREA

DO NOT WRITE IN THIS AREA

