



Oxford Cambridge and RSA

Thursday 08 October 2020 – Morning

A Level Business

H431/01 Operating in a local business environment

Time allowed: 2 hours



You must have:

- the Resource Booklet

You can use:

- a calculator



Please write clearly in black ink. **Do not write in the barcodes.**

Centre number Candidate number

First name(s) _____

Last name _____

INSTRUCTIONS

- Use black ink.
- Write your answer to each question in the space provided. You can use extra paper if you need to, but you must clearly show your candidate number, the centre number and the question numbers.
- Use the Resource Booklet to answer the questions in **Section B**.
- Answer **all** the questions.

INFORMATION

- The total mark for this paper is **80**.
- The marks for each question are shown in brackets [].
- Quality of extended response will be assessed in questions marked with an asterisk (*).
- This document has **20** pages.

ADVICE

- Read each question carefully before you start your answer.

Section A

Answer **all** the questions.

Put a tick (✓) in the box next to the **one** correct answer for each question.

1 Which of the following is a benefit for a firm of effectively managing change during a period of internal reorganisation?

(a) Feedback systems will be less important

(b) Positive attitudes will be encouraged

(c) Profitability will be unaffected

(d) The need for training will be reduced

[1]

2 International Standards, such as ISO 9000, are examples of:

(a) external quality standards

(b) internal quality standards

(c) quality circles

(d) total quality management (TQM)

[1]

3 Which of the following is **not** a characteristic of an entrepreneur?

(a) Ability to work under pressure

(b) Being uncomfortable with risk

(c) Good communication skills

(d) Perseverance when faced with problems

[1]

- 4 While purchasing fuel at a petrol station, Chai buys an expensive chocolate bar. Chai had no intention of buying the chocolate bar until he saw it on display beside the till in the petrol station shop.

Buying the chocolate bar is an example of:

- (a) a loss leader
- (b) an extension strategy
- (c) an impulse purchase
- (d) outsourcing

[1]

- 5 A mission statement:

- (a) describes the strategic vision of the business
- (b) explains the Plan-Do-Review cycle of a business
- (c) lists the tactics the business will use to be successful
- (d) sets a specific and agreed objective

[1]

- 6 GetandGo is a business which delivers parcels to homes across the UK. Which of the following is most likely to be a benefit for GetandGo?

- (a) A decrease in mail order sales
- (b) A preference for the purchase of music from digital channels
- (c) An economic slump
- (d) An increase in the popularity of online retailers

[1]

- 7 Which of the following is likely to be a human resource management objective on a dairy farm?

- (a) To extend the cow sheds to accommodate 50 more cows
- (b) To provide hygiene training to all new farm workers
- (c) To rebrand the milk to appeal to higher income customers
- (d) To sell the milk for a price higher than total cost

[1]

- 8 A cricket club hosts two matches a month. The capacity of the cricket ground is 3000 spectators per match. In April this year, 1800 spectators attended Match 1 and 2200 spectators attended Match 2.

The capacity utilisation of the cricket ground over these two matches was approximately:

- (a) 33%
- (b) 37%
- (c) 67%
- (d) 73%

[1]

- 9 The published accounts of a public limited company provide an incomplete picture of performance because:

- (a) cash-flow information is not included
- (b) only one year of data is included
- (c) qualitative information is not included
- (d) the information is difficult to understand

[1]

- 10 An employment tribunal:

- (a) deals with breaches in employment law
- (b) increases employee participation in decision-making
- (c) is a 360° workforce appraisal technique
- (d) requires a business to implement ethical working practices

[1]

11 The table below gives data for four businesses.

	Business A	Business B	Business C	Business D
Size of workforce	8	36	40	242
Turnover (€)	62 million	1 million	10 million	48 million

According to the EU's standard size definitions, which of these businesses would definitely be categorised as medium-sized?

(a) Business A

(b) Business B

(c) Business C

(d) Business D

[1]

12 Which of the following is a disadvantage to a business of improving its corporate social responsibility (CSR) profile?

(a) The motivation levels of employees are likely to be lowered

(b) The operating costs of the business are likely to increase

(c) The reputation of the business is likely to be damaged

(d) The revenue of the business is likely to fall

[1]

- 13 The diagram below represents the product life cycle of a health drink, which is currently at the stage indicated by 'X'.

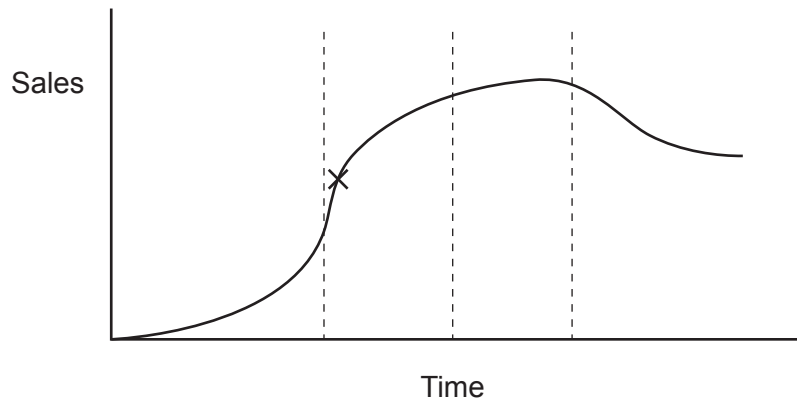

The diagram shows that:

- (a) an extension strategy is currently needed
- (b) demand for the health drink is increasing rapidly
- (c) the business has not yet reached its break-even point
- (d) the health drink is new to the market

[1]

- 14 In a limited liability partnership:

- (a) at least one partner has unlimited liability
- (b) corporation tax is charged on profits
- (c) final accounts must be filed at Companies House
- (d) members can sell shares to family and friends

[1]

15 A critical path network diagram is shown below.

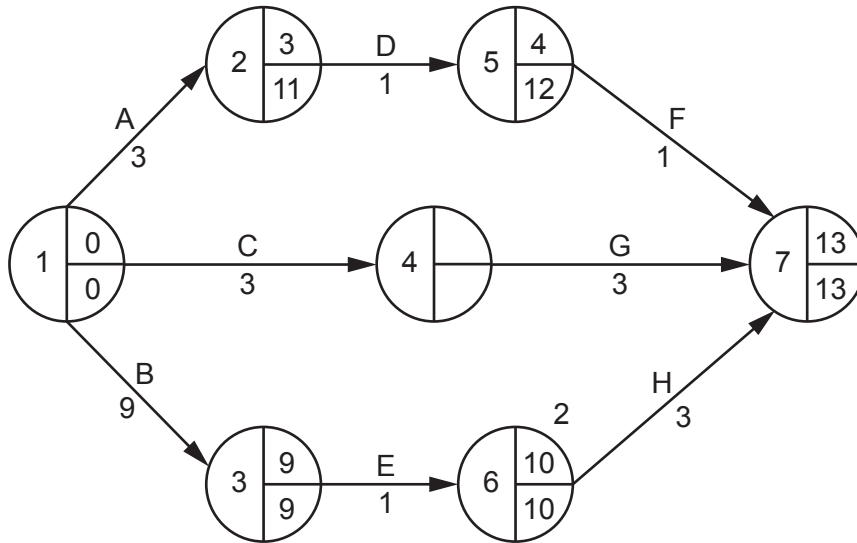

Which of the following shows the earliest start time (EST) and latest finish time (LFT) at node 4?

- (a) EST 3; LFT 3
- (b) EST 3; LFT 10
- (c) EST 10; LFT 3
- (d) EST 10; LFT 10

[1]

A series of 25 horizontal dotted lines spanning the width of the page, intended for writing.

- 19 Paul is charging £5500 per house to the contractor for the heating installation. This is a 35% increase on PTNL's usual price for such a job.

Calculate the price PTNL usually charges for this job.

.....
.....
.....
.....

Answer [2]

- 20 (a) Paul has been told to pay much closer attention to 'the numbers', especially budgets and variances. (Lines 62–63)

The table below shows incomplete budgeting data for a maintenance job completed by PTNL last April.

Complete the missing data in the **three** unshaded boxes.

	Forecast (£)	Actual (£)	Variance (£)	Nature of Variance
Revenue	5150	5375		Favourable
Material Cost		3180	150	Favourable
Equipment Hire	175	205	30	

[3]

- (b)* Evaluate the usefulness of variance analysis to PTNL. [15]

.....
.....
.....
.....
.....
.....
.....
.....
.....
.....
.....
.....

A series of 25 horizontal dotted lines spanning the width of the page, providing a template for handwriting practice.

A series of 25 horizontal dotted lines spanning the width of the page, intended for writing.

.....

.....

.....

.....

.....

.....

.....

.....

.....

.....

.....

.....

.....

.....

.....

.....

.....

.....

.....

.....

.....

.....

.....

21* “Paul has decided to write a contingency plan.” (Line 64)

Recommend the key issues that a contingency plan for PTNL should consider. Justify your answer. **[15]**

.....

.....

.....

.....

.....

.....

.....

.....

.....

.....

A series of 25 horizontal dotted lines spanning the width of the page, providing a template for handwriting practice.

PLEASE DO NOT WRITE ON THIS PAGE

OCR

Oxford Cambridge and RSA

Copyright Information

OCR is committed to seeking permission to reproduce all third-party content that it uses in its assessment materials. OCR has attempted to identify and contact all copyright holders whose work is used in this paper. To avoid the issue of disclosure of answer-related information to candidates, all copyright acknowledgements are reproduced in the OCR Copyright Acknowledgements Booklet. This is produced for each series of examinations and is freely available to download from our public website (www.ocr.org.uk) after the live examination series.

If OCR has unwittingly failed to correctly acknowledge or clear any third-party content in this assessment material, OCR will be happy to correct its mistake at the earliest possible opportunity.

For queries or further information please contact The OCR Copyright Team, The Triangle Building, Shaftesbury Road, Cambridge CB2 8EA.

OCR is part of the Cambridge Assessment Group; Cambridge Assessment is the brand name of University of Cambridge Local Examinations Syndicate (UCLES), which is itself a department of the University of Cambridge.